

USA office: Fontana **AUS** office: Truganina

GBR office: FDS Corporation Limited, Unit 4, Blackacre Road, Great Blakenham,
Ipswich, Ip6 0FL, United Kingdom

If you're having difficulty, our friendly
customer team is always here to help.



USA:cs.us@costway.com
AUS:cs.au@costway.com
GBR:cs.uk@costway.com

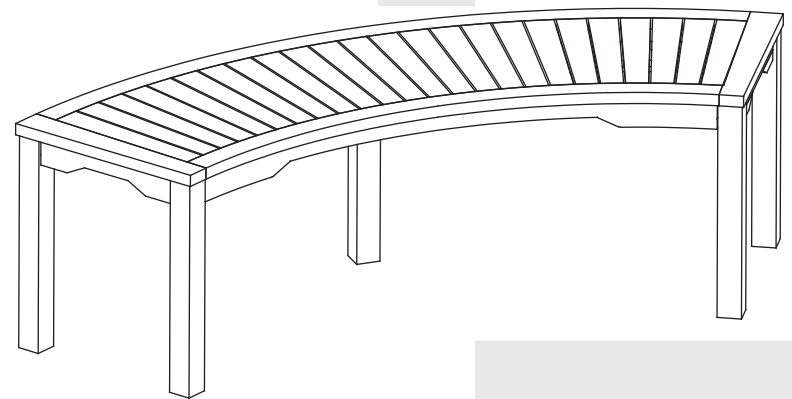

Wood Curved Bench
HW72952-1

THIS INSTRUCTION BOOKLET CONTAINS **IMPORTANT** SAFETY INFORMATION.
PLEASE READ AND KEEP FOR FUTURE REFERENCE.



Before You Start

- ⚠ Please read all instructions carefully.
- ⚠ Retain instructions for future reference.
- ⚠ Separate and count all parts and hardware.
- ⚠ Read through each step carefully and follow the proper order.
- ⚠ We recommend that, where possible, all items are assembled near to the area in which they will be placed in use, to avoid moving the product unnecessarily once assembled.
- ⚠ Always place the product on a flat, steady and stable surface.
- ⚠ Keep all small parts and packaging materials for this product away from babies and children as they potentially pose a serious choking hazard.

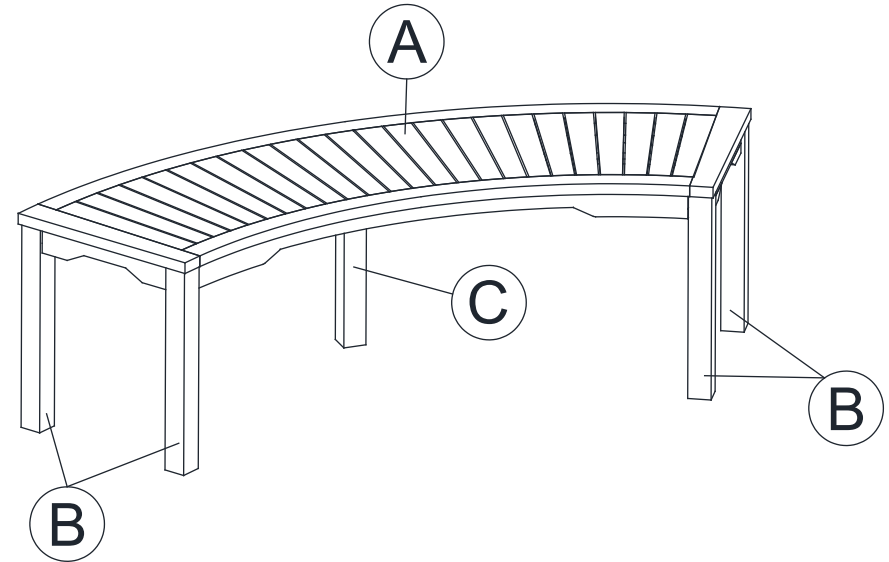

Note:

1. 50% tighten before all screws are in place. Allen wrench is recommended instead of an electric drill.
2. Place the item on a flat ground to adjust and make sure it remains stable. Tighten up all screws with tools gradually.
3. If the screws are not aligned with holes during assembly, please loosen all the other screws to 50% and continue the assembly process.
4. If the item is not stable, please loosen all the screws, adjust it on a flat ground and tighten up all screws again.
5. If one or some screws are fully tightened during assembly, the others may not be aligned with the holes, resulting in assembly failure. However, all the holes are designed to be relatively larger to provide more space for the adjustment of the screws.

Parts List

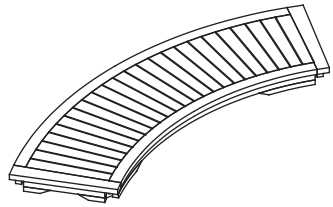

(A) x1



(B) x4



(C) x1

Hardware List

BOLT

(1) x8

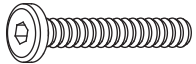

M6 x 50mm

BOLT

(2) x2

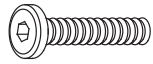

M6 x 40mm

STEEL WASHER

(3) x10



M6x18x2

ALLEN KEY

(4) x1



M4

1

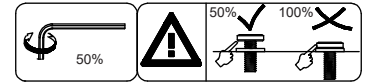
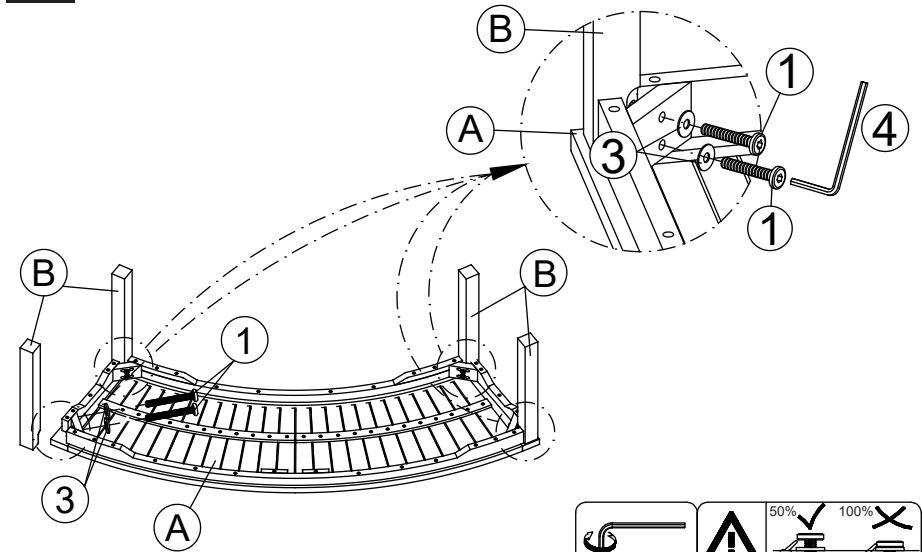

2

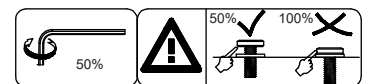
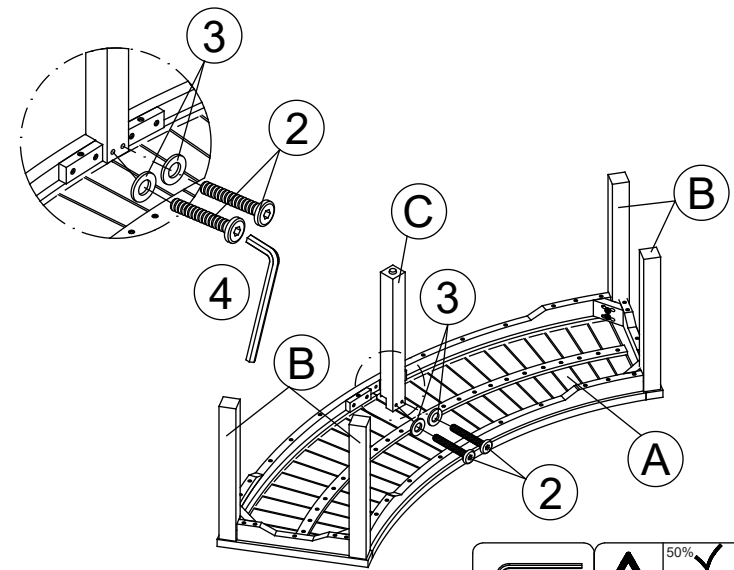

3

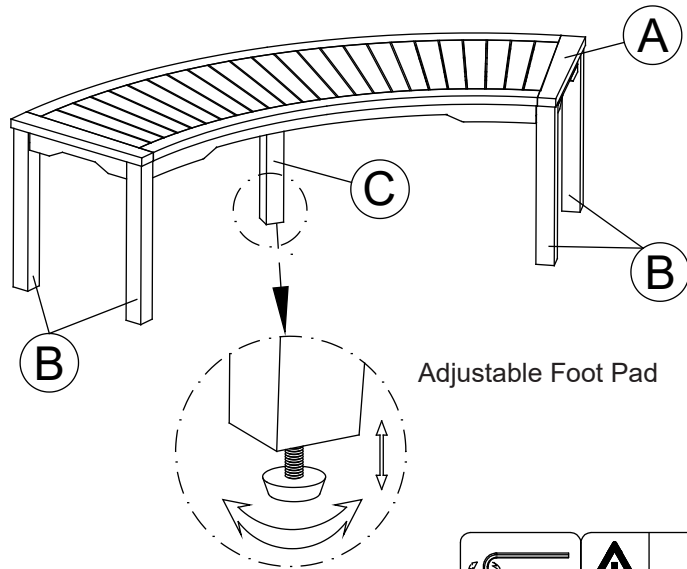

Adjustable Foot Pad

4

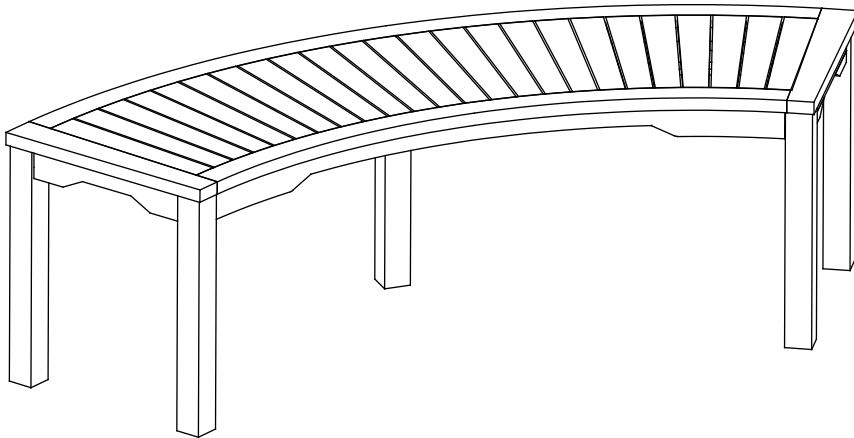

Return / Damage Claim Instructions

- ⚠ **DO NOT discard the box / original packaging.**
In case a return is required, the item must be returned in original box. Without this your return will not be accepted.
- ⚠ **Take a photo of the box markings.**
A photo of the markings (text) on the side of the box is required in case a part is needed for replacement. This helps our staff identify your product number to ensure you receive the correct parts.
- ⚠ **Take a photo of the damaged part (if applicable).**
A photo of the damage is always required to file a claim and get your replacement or refund processed quickly. Please make sure you have the box even if it is damaged.
- ⚠ **Send us an email with the images requested.**
Email us directly from marketplace where your item was purchased with the attached images and a description of your claim.