

USA office: Fontana

AUS office: Truganina

FRA office: Saint Vigor d'Ymonville

GBR office: FDS Corporation Limited, Unit 4, Blackacre Road, Great Blakenham, Ipswich, Ip6 0FL, United Kingdom

If you're having difficulty, our friendly customer team is always here to help.



USA:cs.us@costway.com
AUS:cs.au@costway.com
GBR:cs.uk@costway.com
FRA:cs.fr@costway.com

Outdoor Storage Shed
Abri de Rangement pour l'Extérieur

GT4194

THIS INSTRUCTION BOOKLET CONTAINS **IMPORTANT** SAFETY INFORMATION.
PLEASE READ AND KEEP FOR FUTURE REFERENCE.



Before You Start

- ⚠ Please read all instructions carefully.
- ⚠ Retain instructions for future reference.
- ⚠ Separate and count all parts and hardware.
- ⚠ Read through each step carefully and follow the proper order.
- ⚠ We recommend that, where possible, all items are assembled near to the area in which they will be placed in use, to avoid moving the product unnecessarily once assembled.
- ⚠ Always place the product on a flat, steady and stable surface.
- ⚠ Keep all small parts and packaging materials for this product away from babies and children as they potentially pose a serious choking hazard.







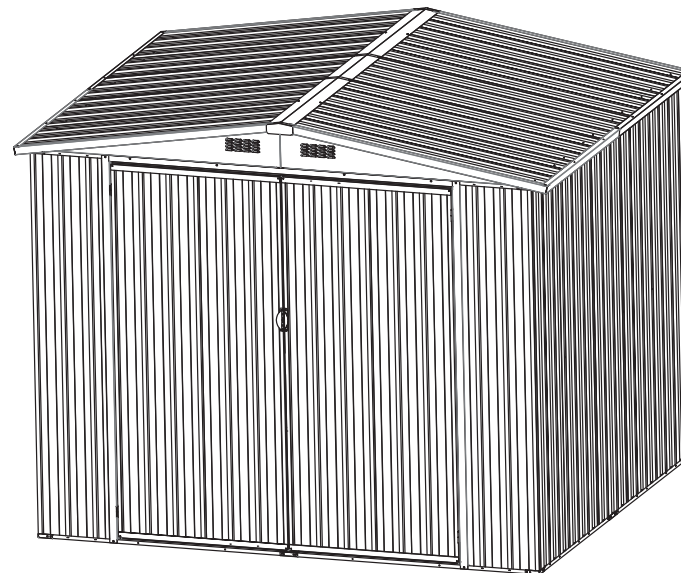

Avant de Commencer

- ⚠ Veuillez lire attentivement toutes les instructions.
- ⚠ Conservez les instructions pour vous y référer ultérieurement.
- ⚠ Vérifiez toutes les pièces et les accessoires.
- ⚠ Lisez attentivement chaque étape et suivez l'ordre correct.
- ⚠ Nous recommandons que, dans la mesure du possible, tous les produits soient assemblés à proximité de la zone où ils seront utilisés, afin d'éviter tout déplacement inutile du produit une fois assemblé.
- ⚠ Placez toujours le produit sur une surface plane et stable.
- ⚠ Conservez toutes les petites pièces de ce produit et les matériaux d'emballage hors de portée des bébés et des enfants, car ils pourraient présenter un risque d'étouffement.

INSTALLATION INSTRUCTIONS /INSTRUCTIONS D'INSTALLATION

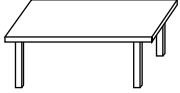

Required tools / Outils nécessaires

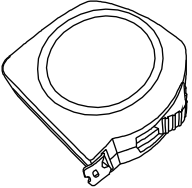
 <p>Gloves / Gants</p>	 <p>Safety Glasses / Lunettes de sécurité</p>
 <p>Table / Table</p>	 <p>Ladder / Échelle</p>
 <p>Power drill / Perceuse électrique</p>	 <p>Screw drive / Tournevis</p>
 <p>Power drill / Crayon</p>	 <p>Tape Measure / Ruban à mesurer</p>

EN

Tips:

1. Clear a working area to allow access on 4 sides. A raised work surface will make assembly easier, It is easier to install the wall panel on the table.
2. All parts are identified so when working through the instructions page by page the diagrams show where each part is positioned.
3. Most pre-punched holes need to be fixed with self-tapping screws, and a few holes need to use self-drilling screws.
4. Before starting, to avoid any accidental injury, we recommend the use of gloves to protect your hands, safety glasses to protect your eyes and shoes or boots to protect your feet.
5. Please keep children away from your construction site.
6. Most assembly can be completed by one person, assistance may be needed when you reach the erection stage.
7. Please note: Some local government authorities have rules & regulations on shed installation and you may need approval to erect this shed.

Steps:

1. Unpack all components from the carton and lay outside your work area and check parts against the part list.
2. Work through assembly instructions page by page.
3. When assembly completed, place the shed in position and fix anchor to the ground.
4. Clean up all metal pieces and screws.

BEFORE YOU START - HOW PANELS ARE JOINED

Position U channel over one end of the joined sheets, working from one end push channel down to clip onto sheets, continue to the end of the channel pushing as you go.

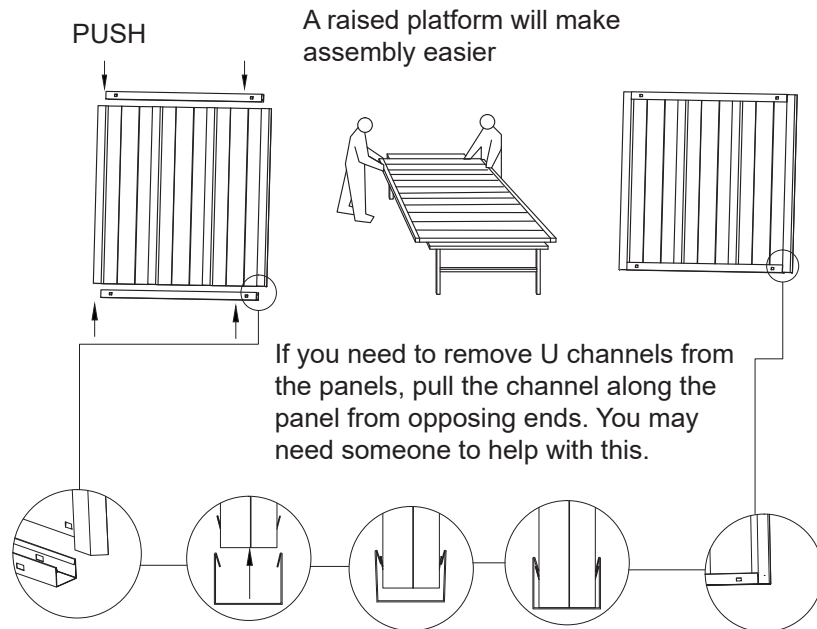

FR

Conseils:

1. Dégagez un espace de travail pour permettre l'accès sur les 4 côtés. Une surface de travail surélevée facilitera l'assemblage, il est plus facile d'installer le panneau mural sur la table.
2. Toutes les pièces sont identifiées, de sorte que lorsque vous lisez les instructions page par page, les diagrammes indiquent la position de chaque pièce.
3. La plupart des trous pré-perforés doivent être fixés à l'aide de vis autotaraudeuses, et quelques trous doivent être fixés à l'aide de vis auto-perceuses.
- 4 Avant de commencer, pour éviter toute blessure accidentelle, nous vous recommandons de porter des gants pour protéger vos mains, des lunettes de sécurité pour protéger vos yeux et des chaussures ou des bottes pour protéger vos pieds.
5. Veuillez tenir les enfants à l'écart de votre chantier de construction.
6. La plupart des opérations d'assemblage peuvent être réalisées par une seule personne, mais une assistance peut être nécessaire lorsque vous atteignez le stade de l'érection.
7. Veuillez noter que certaines autorités locales ont des règles et des réglementations concernant l'installation des cabanons et qu'il se peut que vous ayez besoin d'une autorisation pour ériger ce cabanon.

Étapes:

1. Déballez tous les composants du carton et placez-les à l'extérieur de votre zone de travail, puis vérifiez les pièces par rapport à la liste des pièces.
2. Lisez les instructions d'assemblage page par page.
3. Une fois l'assemblage terminé, placez l'abri en position et fixez l'ancrage au sol.
4. Nettoyez toutes les pièces métalliques et les vis.

AVANT DE COMMENCER - COMMENT LES PANNEAUX SONT ASSEMBLÉS

Placez le profilé en U sur l'une des extrémités des feuilles jointes, en commençant par une extrémité, poussez le profilé vers le bas pour le clipser sur les feuilles, continuez jusqu'à l'extrémité du profilé en poussant au fur et à mesure.

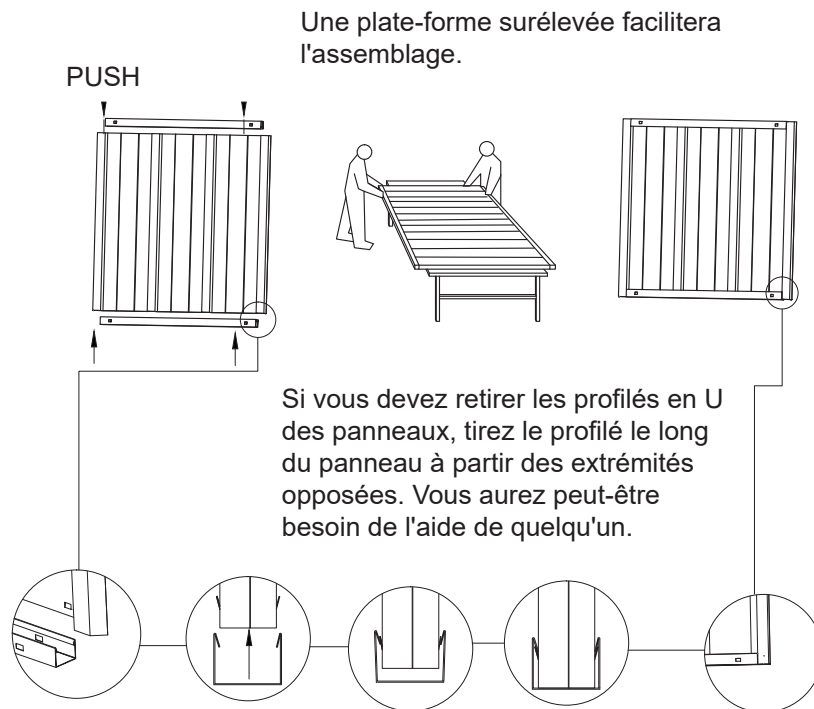

HOW TO JOIN CHANNELS (where needed)

/ COMMENT JOINDRE LES CANALISATIONS (si nécessaire)

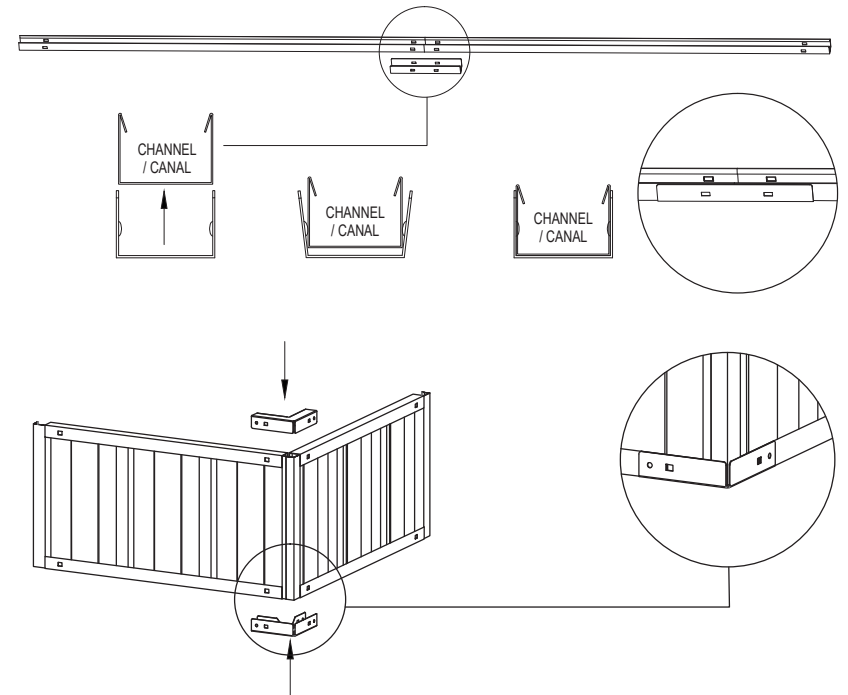



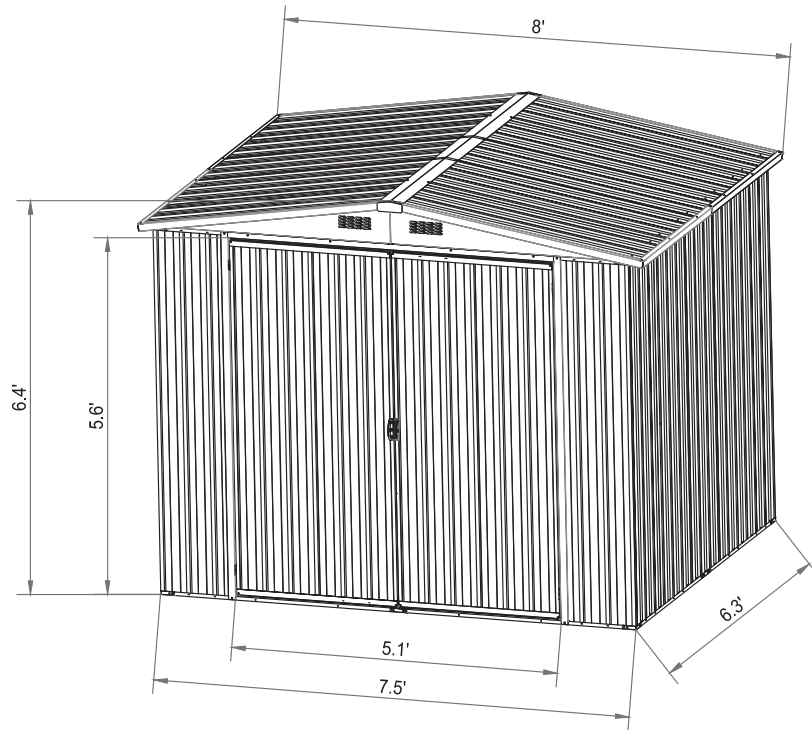



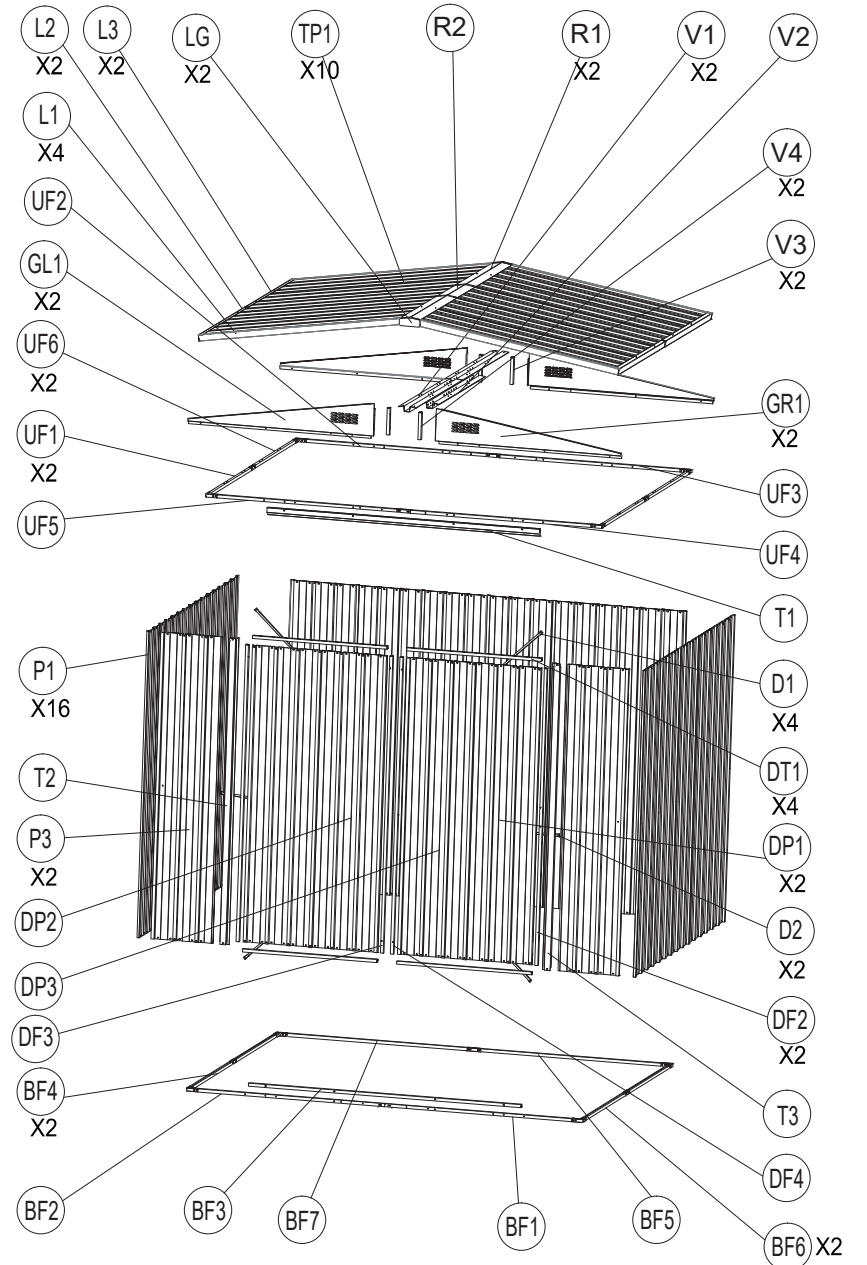

















Size Drawing / Schéma des Dimensions



ASSEMBLY BREAKDOWN DRAWING / SCHÉMA DE DÉCOMPOSITION DE L'ASSEMBLAGE

















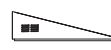















Storage Shed BOX-1/2
/ Abri de stockage BOÎTE-1/2

NO. / N°	PART / PARTIE	QTY / QTÉ	NO. / N°	PART / PARTIE	QTY / QTÉ
TP1		10	BF2		1
P1		2	BF3		1
P3		2	BF4		2
DP2		1	BF5		1
DP3		1	DF2		2
UF2		1	DF3		1
UF3		1	L1		4
UF4		1	L2		2
UF5		1	L4		2
UF6		2	DT1		4
BF1		1	V1		2
V2		1	UF1		2

BF6		2	BF7		1
DF4		1			







Storage Shed BOX-2/2
/ Abri de stockage BOÎTE-2/2

NO. / N°	PART / PARTIE	QTY / QTÉ	NO. / N°	PART / PARTIE	QTY / QTÉ
P1		14	EG1		8
DP1		2	EJ1		8
GL1		2	EH1		2
GR1		2	L3		57
D1		4	LB		4
D2		2	S18		215
R1		2	S5		89
R2		1	C7		8

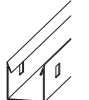
T1		1	S11		8
T2		1	V3		2
T3		1	V4		2
ELG		2	ED3		1
H2		1	S19		24
H3		1	S16		4
SH3		6	Gloves / Gants		2
			Lock / Serrure		1
C20		2	Assembly Instructions / Instructions d'Assemblage		1

PANEL ASSEMBLY REAR WALL

ASSEMBLAGE DES PANNEAUX PAROI ARRIÈRE

	P1	6		UF2	1
	BF5	1		UF3	1
	EJ1	2		S18	5
	BF7	1		S5	5

1

Hole alignment / Alignement des trous

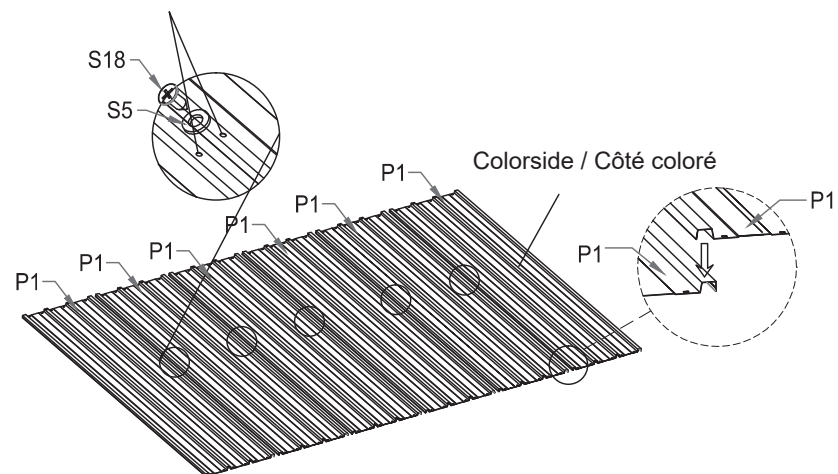

2

Make sure the arrow labels opposite.
 / Assurez-vous que les étiquettes des flèches sont opposées.

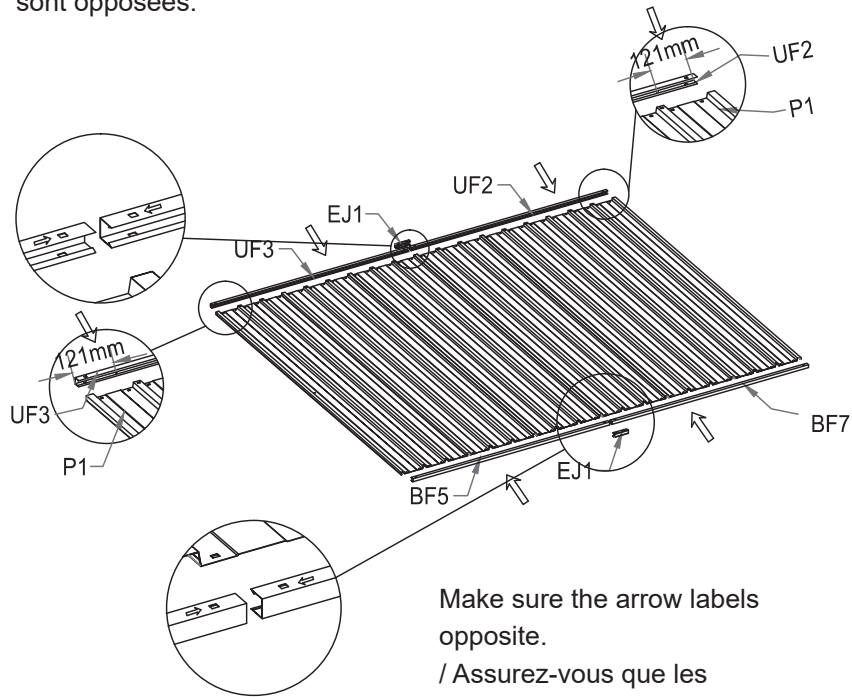

Make sure the arrow labels opposite.
 / Assurez-vous que les étiquettes des flèches sont opposées.

3

S18



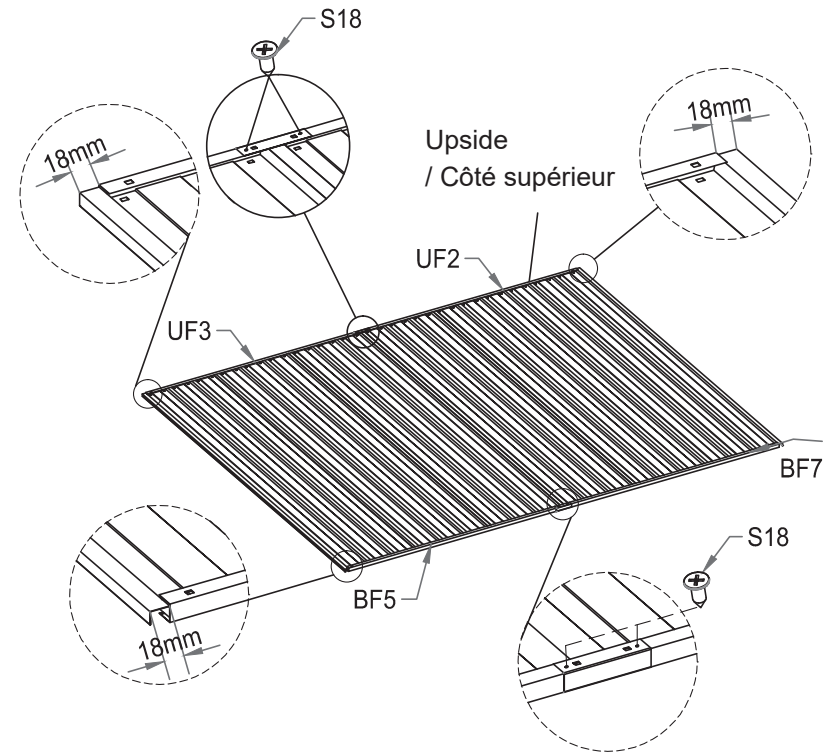





4

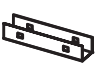

Drill S18 on color side, no need to drill the other side.
 / Percez S18 du côté coloré, il n'est pas nécessaire de percer l'autre côté.

**PANEL ASSEMBLY
LEFT & RIGHT
WALL**

**ASSEMBLAGE DE
PANNEAUX
PAROI GAUCHE
ET DROITE**

	P1	5		UF1	1
	BF4	1		UF6	1
	EJ1	2		S18	4
	BF6	1		S5	4

X 2

Repeat left wall's assembly steps for right wall.
/ Répétez les étapes d'assemblage du mur gauche pour le mur droit.

1

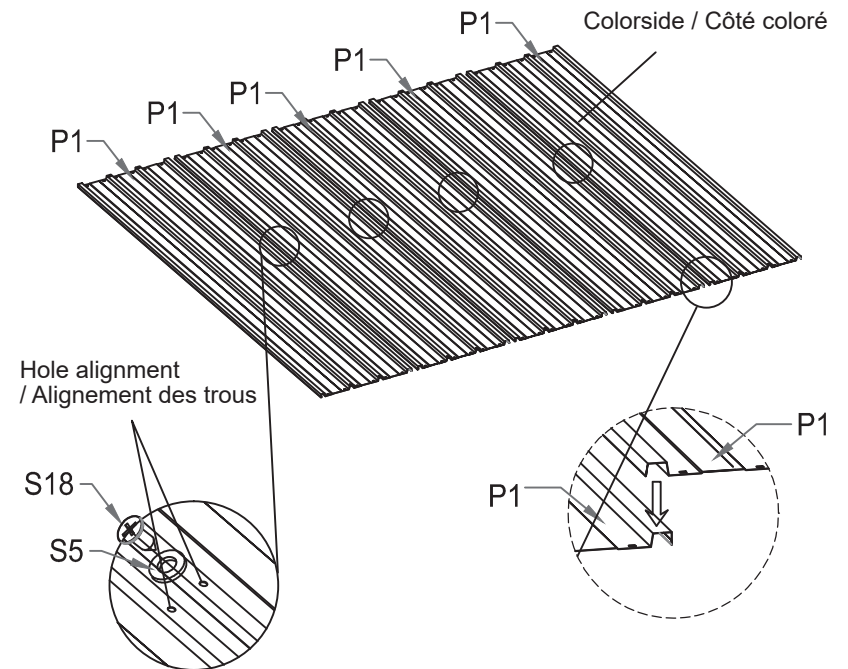

X 2

2

Make sure the arrow labels
opposite.
/ Assurez-vous que les
étiquettes des flèches sont
opposées.

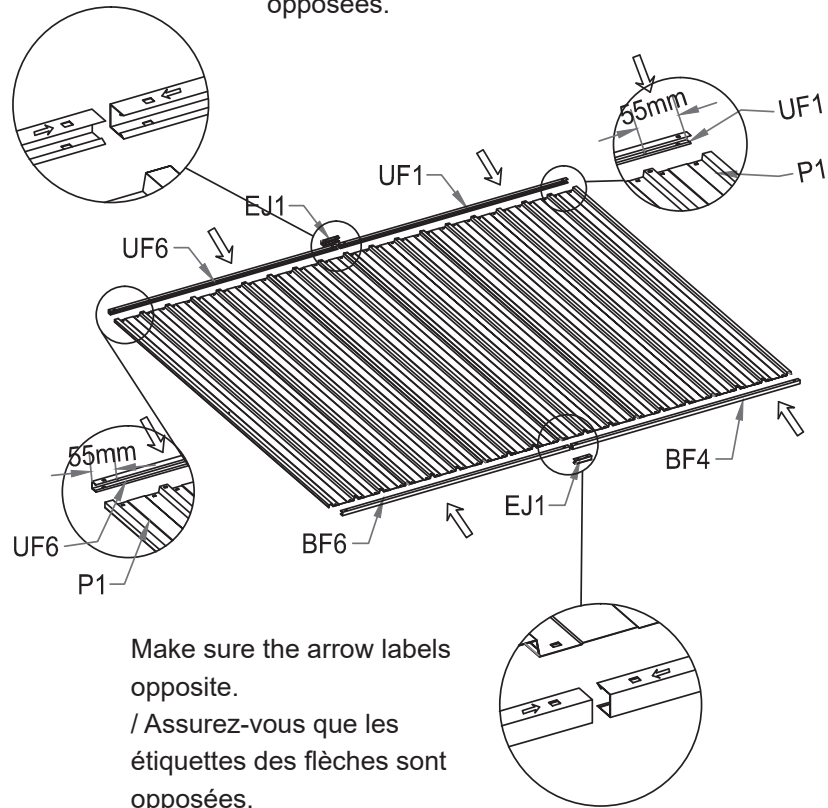

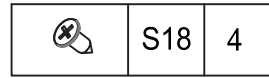
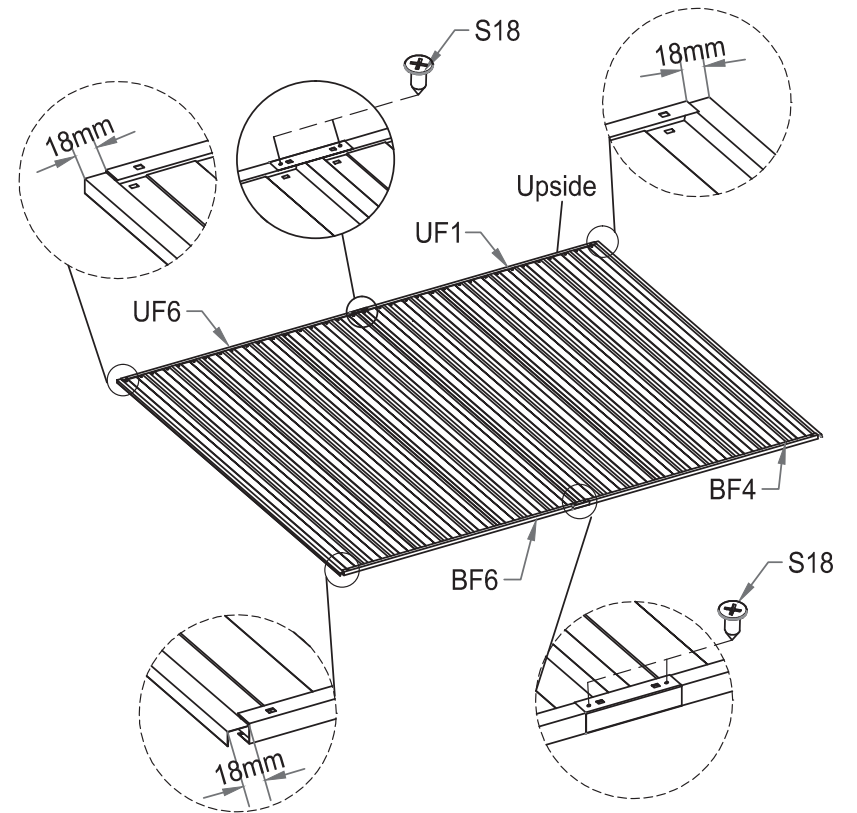

Make sure the arrow labels
opposite.
/ Assurez-vous que les
étiquettes des flèches sont
opposées.

X 2**3****X 2****X 2**

Drill S18 on color side, no need to drill the other side.
/ Percez S18 du côté coloré, il n'est pas nécessaire de percer l'autre
côté.

PANEL ASSEMBLY REAR WALL

ASSEMBLAGE DES PANNEAUX PAROI ARRIÈRE

	P3	2		UF4	1		UF5	1
	BF2	1		BF1	1			

1

Conseils: L'espacement des trous est de 327 mm vers le côté coloré.

PART A / PARTIE A

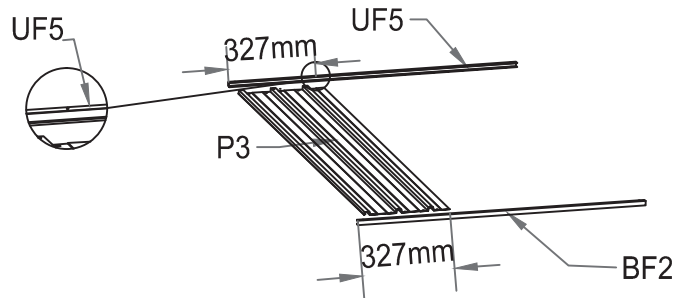

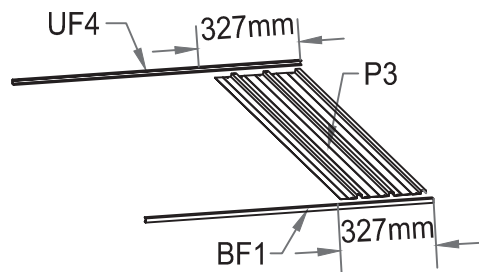

PART B / PARTIE B

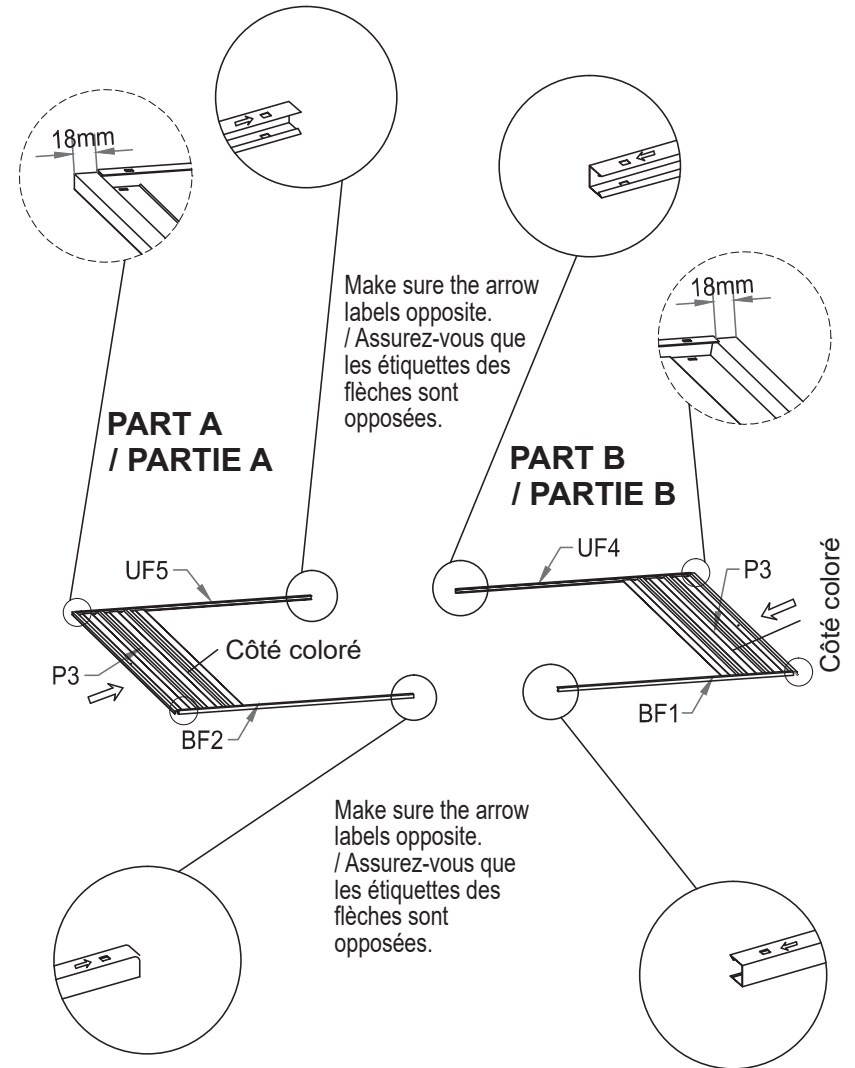

2



3

	S18	4		T2	1		T3	1
---	-----	---	---	----	---	---	----	---

**PART A
/ PARTIE A**

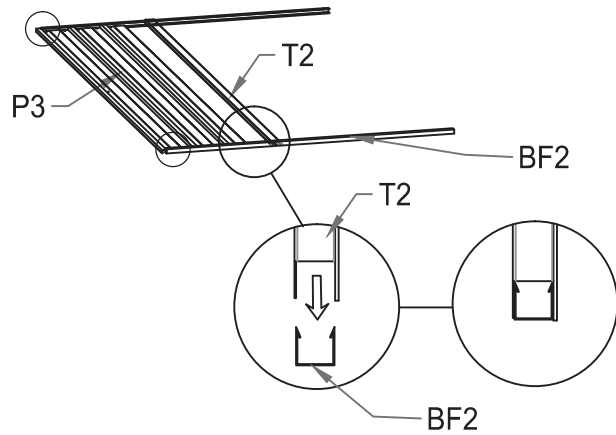

**PART B
/ PARTIE B**

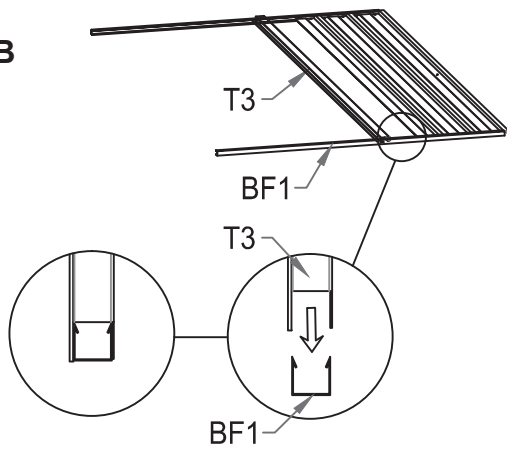

4

**PART A
/ PARTIE A**

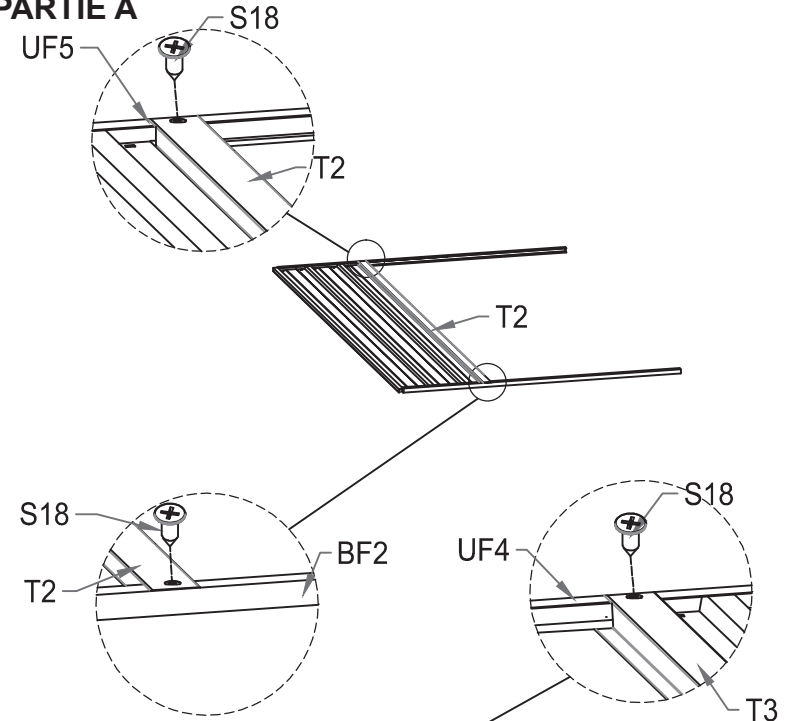

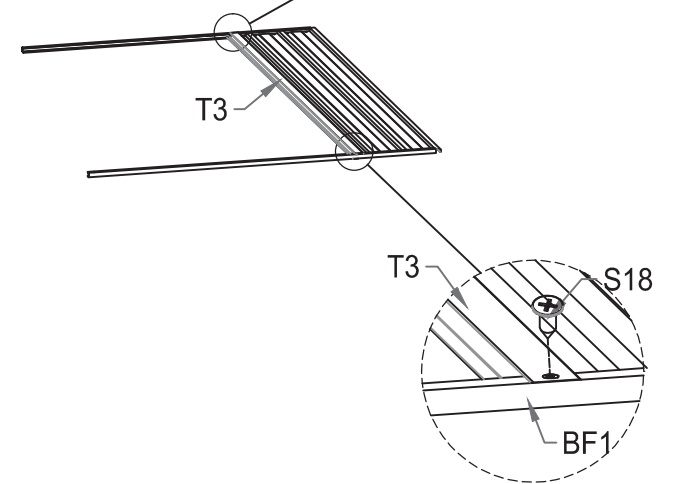

**PART B
/ PARTIE B**





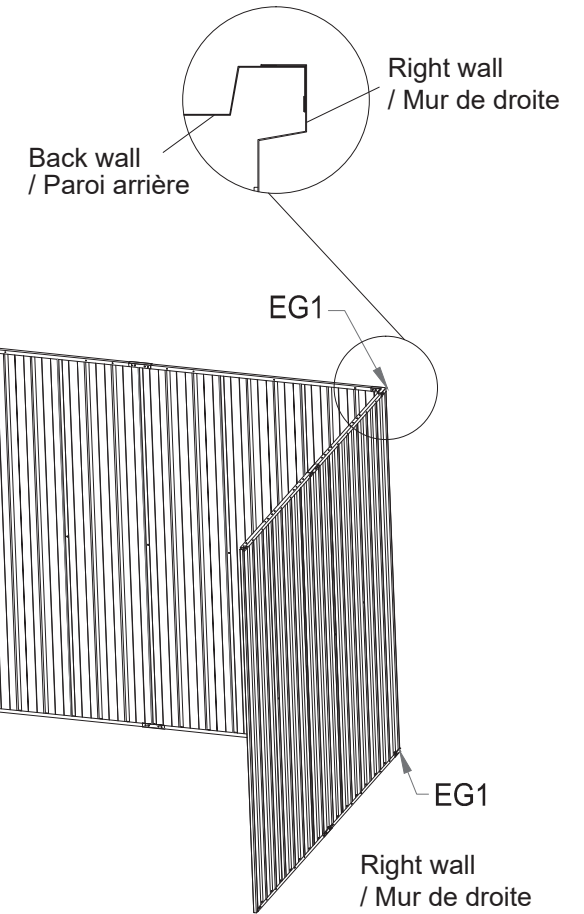
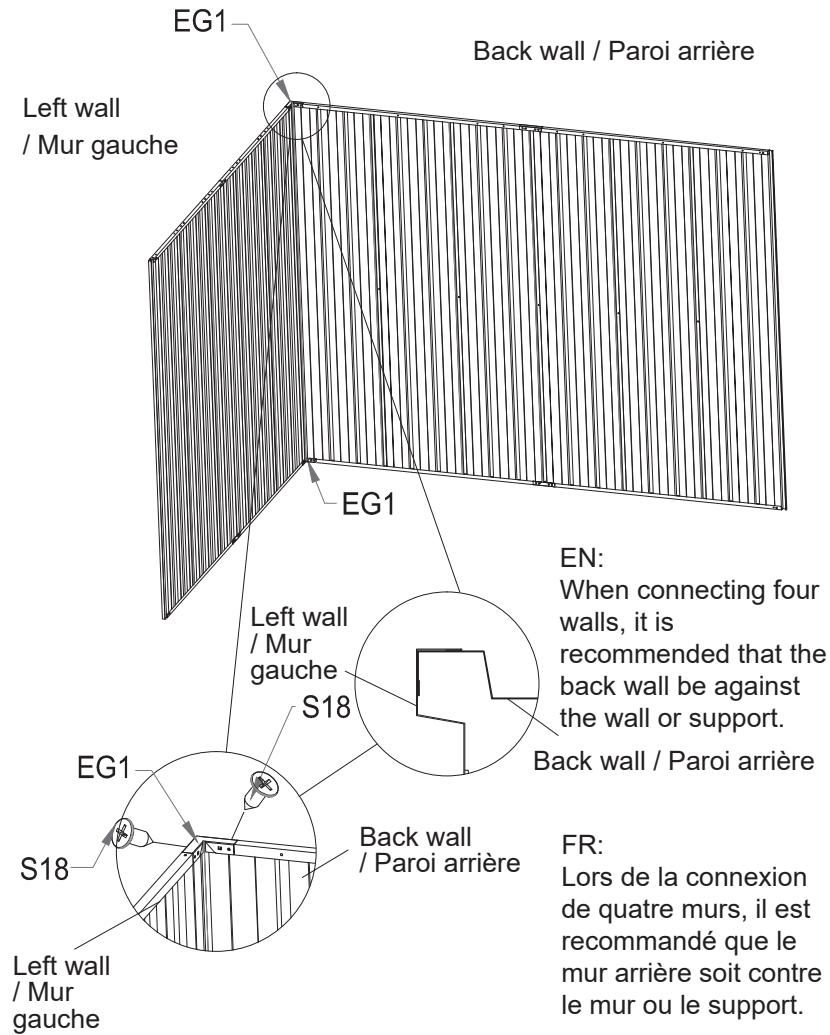

SHED ASSEMBLY JOINING WALL

ASSEMBLAGE DE L'ABRI MUR DE JONCTION

	EG1	4		S18	8
---	-----	---	---	-----	---



	EG1	4		S18	20		EJ1	2		S5	4
---	-----	---	---	-----	----	---	-----	---	---	----	---

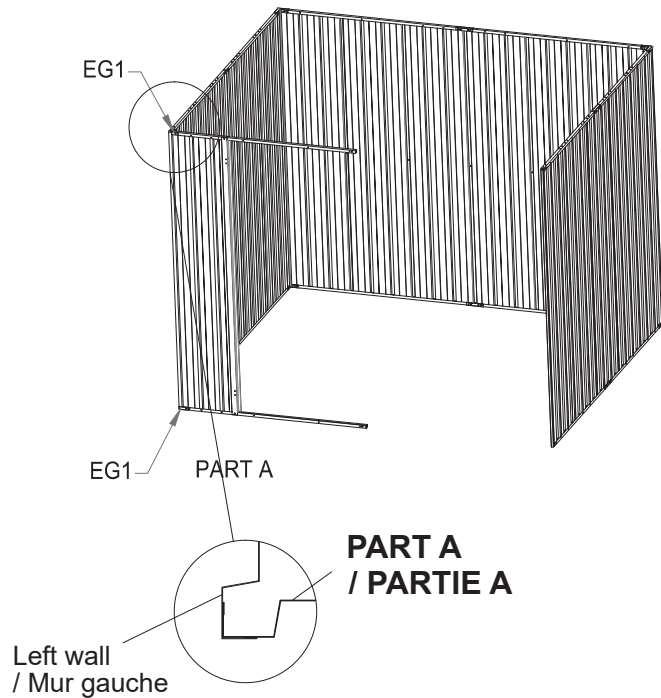

EN:
When connecting four walls, it is recommended that the back wall be against the wall or support.

FR:
Lors de la connexion de quatre murs, il est recommandé que le mur arrière soit contre le mur ou le support.

EN:
Drill S18 on color side, no need to drill the other side.

FR:
Percez S18 du côté de la couleur, il n'est pas nécessaire de percer l'autre côté.

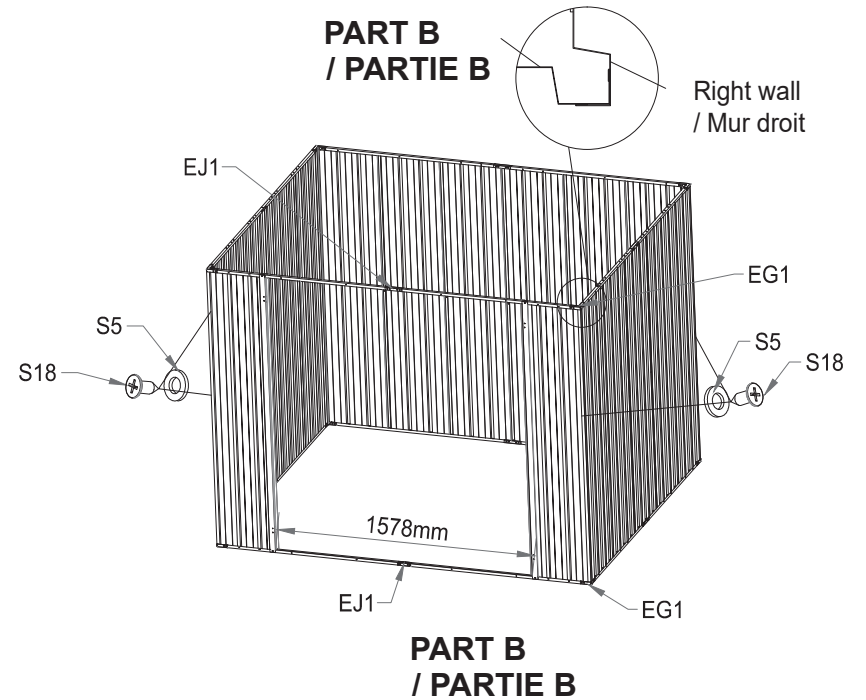

EN:
When two walls overlap, make sure side wall is outside.



FR:
Lorsque deux murs se chevauchent, s'assurer que le mur latéral est à l'extérieur.

EN:
Fix the corner of walls with screw S18.

FR:
Fixez l'angle des murs avec la vis S18.

ANCHORING ASSEMBLY

ASSEMBLAGE DE L'ANCRAGE

	C7	8		S11	8
---	----	---	---	-----	---

1

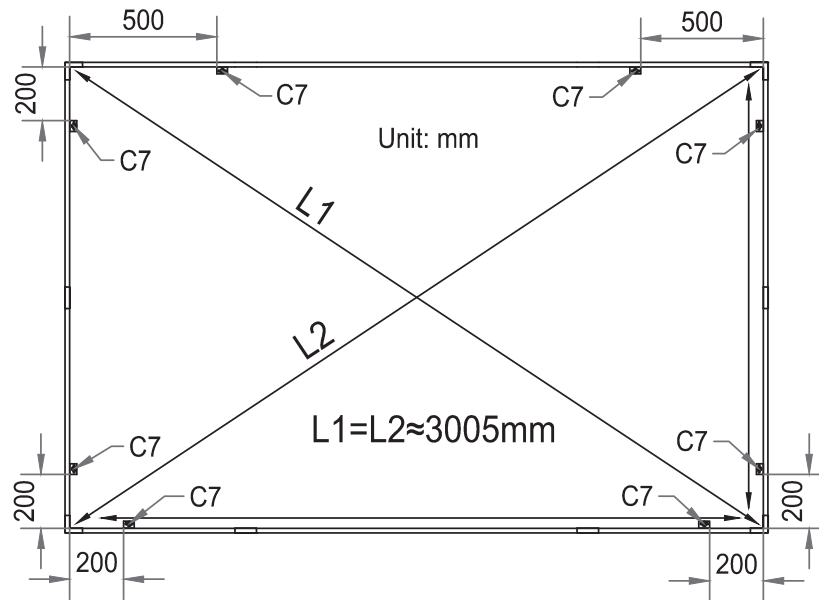

EN:

1. The shed is now free standing. It is critical at this stage to ensure the shed is leveled.
2. Then measure the diagonal distance and make sure the four side walls are squared to 90 degrees.
3. Use anchor kit (C7& S11) when fixing to a concrete base. Fastening the anchor kit onto a concrete pad
 - 3.1 Mark the place of the anchor on the ground.
 - 3.2 Use 10mm -0.39" concrete drill bit and drill holes 60mm-2.4" deep.
 - 3.3 Tap concrete fixing bolts into the hole, place anchor, add washer and nut and fasten.

FR:

1. L'abri est maintenant libre. Il est essentiel à ce stade de s'assurer que l'abri est de niveau.
2. Mesurez ensuite la distance diagonale et assurez-vous que les quatre murs latéraux sont équerres à 90 degrés.
3. Utilisez le kit d'ancrage (C7& S11) pour la fixation sur une base en béton. Fixez le kit d'ancrage sur une base en béton.
 - 3.1 Marquez l'emplacement de l'ancrage sur le sol.
 - 3.2 Utilisez une mèche à béton de 10 mm -0,39" et percez des trous de 60 mm-2,4" de profondeur.
 - 3.3 Tapez les boulons de fixation pour béton dans le trou, placez l'ancrage, ajoutez la rondelle et l'écrou et fixez.

2

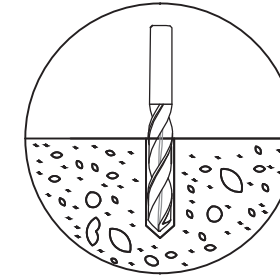

3

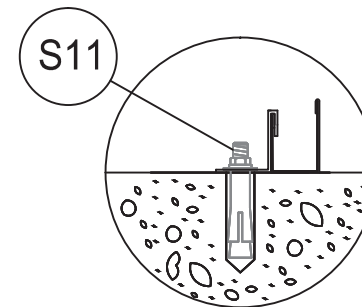

4

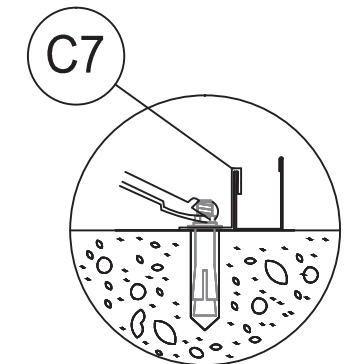

SHED ASSEMBLY TRIANGLE / ASSEMBLAGE DE L'ABRI TRIANGLE

	V4	2		GL1	2		S18	24
	GR1	2		L3	4			
	T1	1		V3	2		BF3	1

EN:
Notice the direction of the arrow

FR:
Remarquez le sens de la flèche

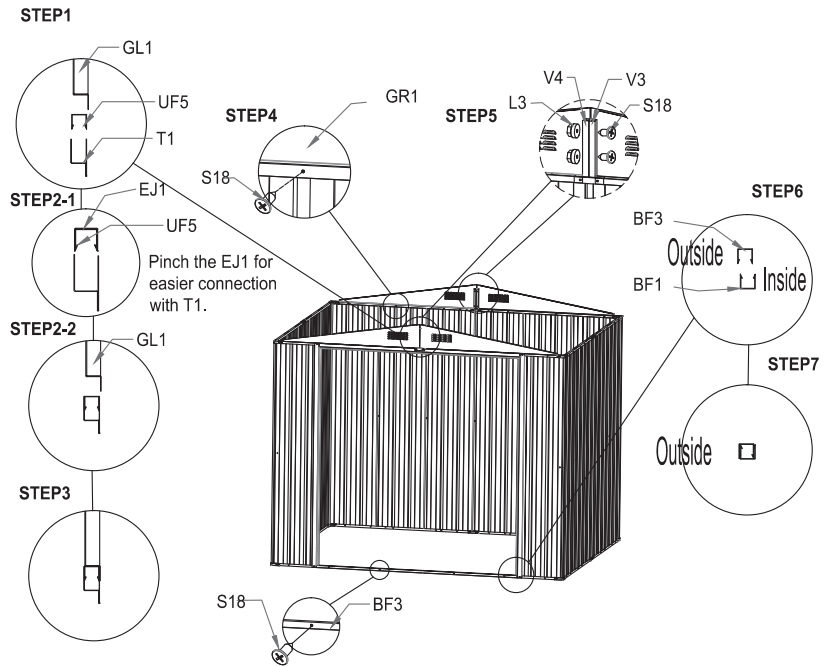
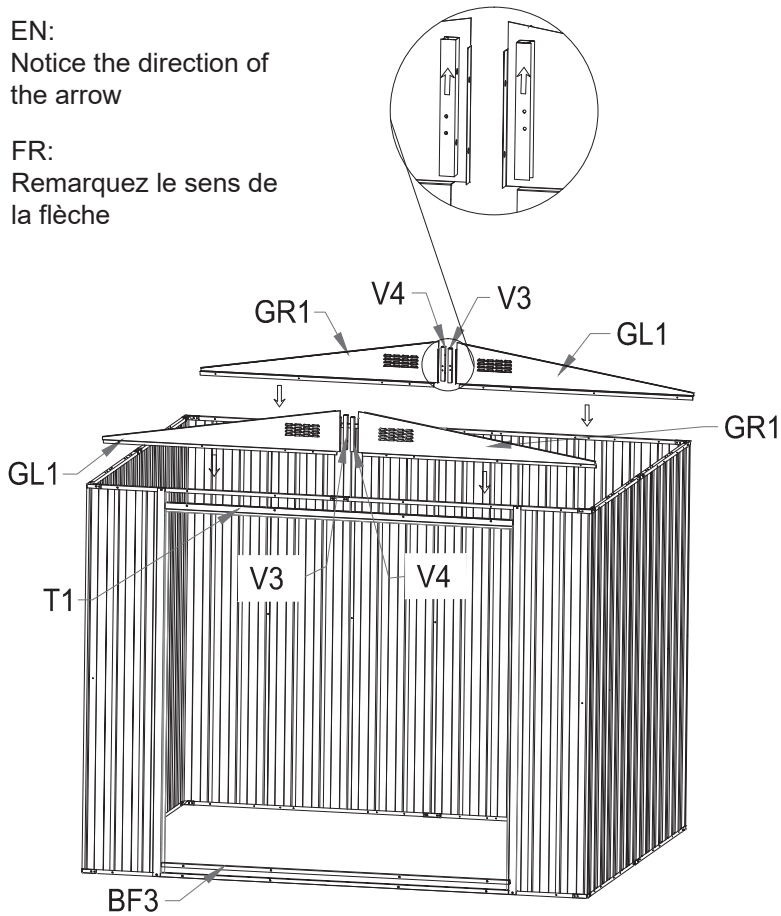



EN:
Pinch the EJ1 for easier connection with T1.

FR:
Pincez l'EJ1 pour faciliter la connexion avec T1.

EN:	FR:	
STEP1	ÉTAPE 1	
STEP2-1	ÉTAPE 2-1	
STEP2-2	ÉTAPE 2-2	Outside / Extérieur
STEP3	ÉTAPE 3	Inside / Intérieur
STEP4	ÉTAPE 4	
STEP5	ÉTAPE 5	
STEP6	ÉTAPE 6	
STEP7	ÉTAPE 7	

SHED ASSEMBLY MAIN BEAM

ASSEMBLAGE DE L'ABRI POUTRE PRINCIPALE

	C20	2		S18	12
---	-----	---	---	-----	----

	V1	2		V2	1		S18	8
---	----	---	---	----	---	---	-----	---

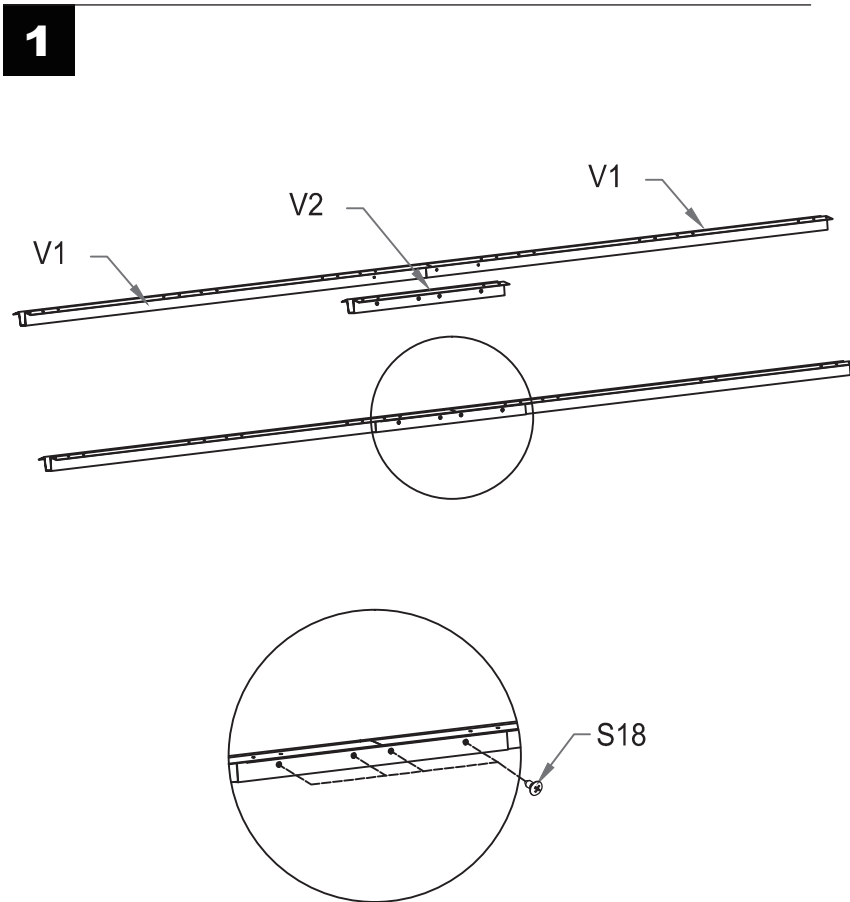

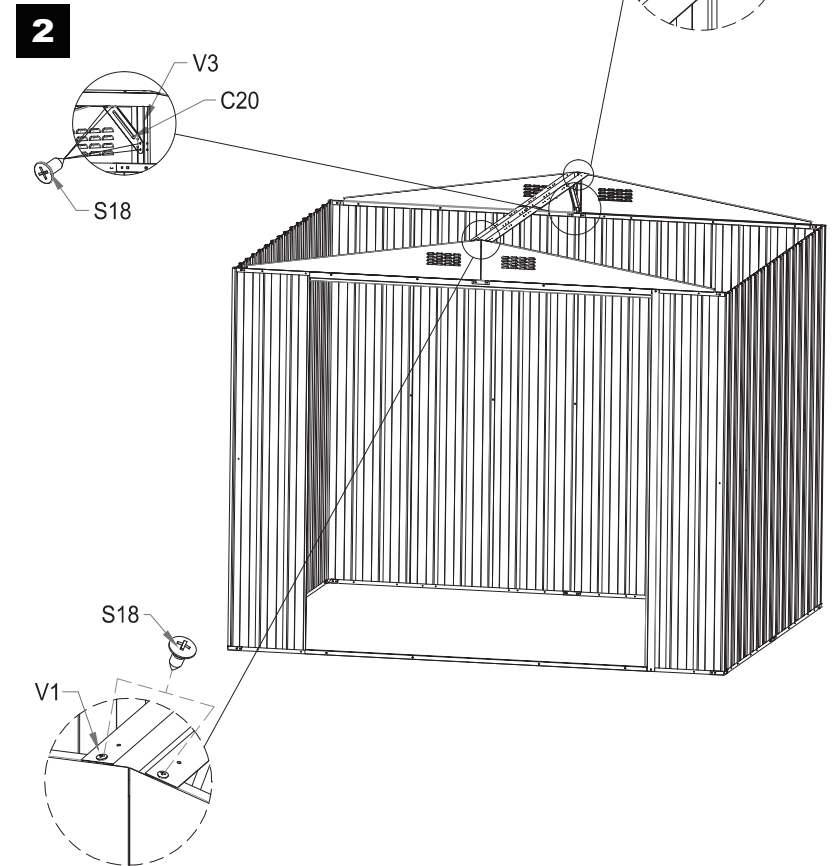

EN:
Two sets of holes for installing C20. Only need to choose one set of holes.

FR:
Deux séries de trous pour l'installation du C20, il suffit de choisir une série de trous.



SHED ASSEMBLY ROOF PANEL



ASSEMBLAGE DE L'ABRI PANNEAU DE TOIT

	TP1	4		S18	16		S5	16
---	-----	---	---	-----	----	---	----	----

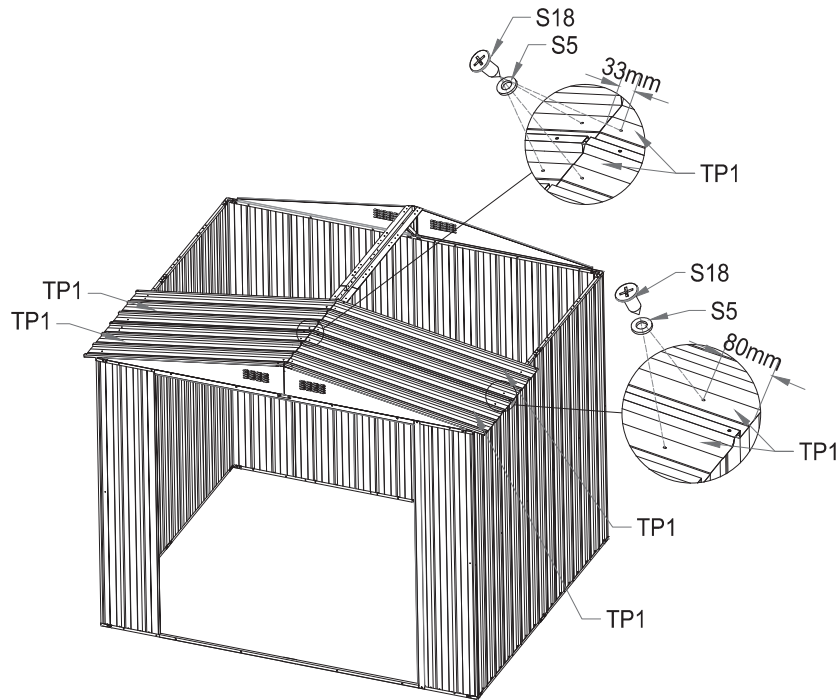

EN:
Do not fix screws at
this step

FR:
Ne pas fixer les vis à
cette étape

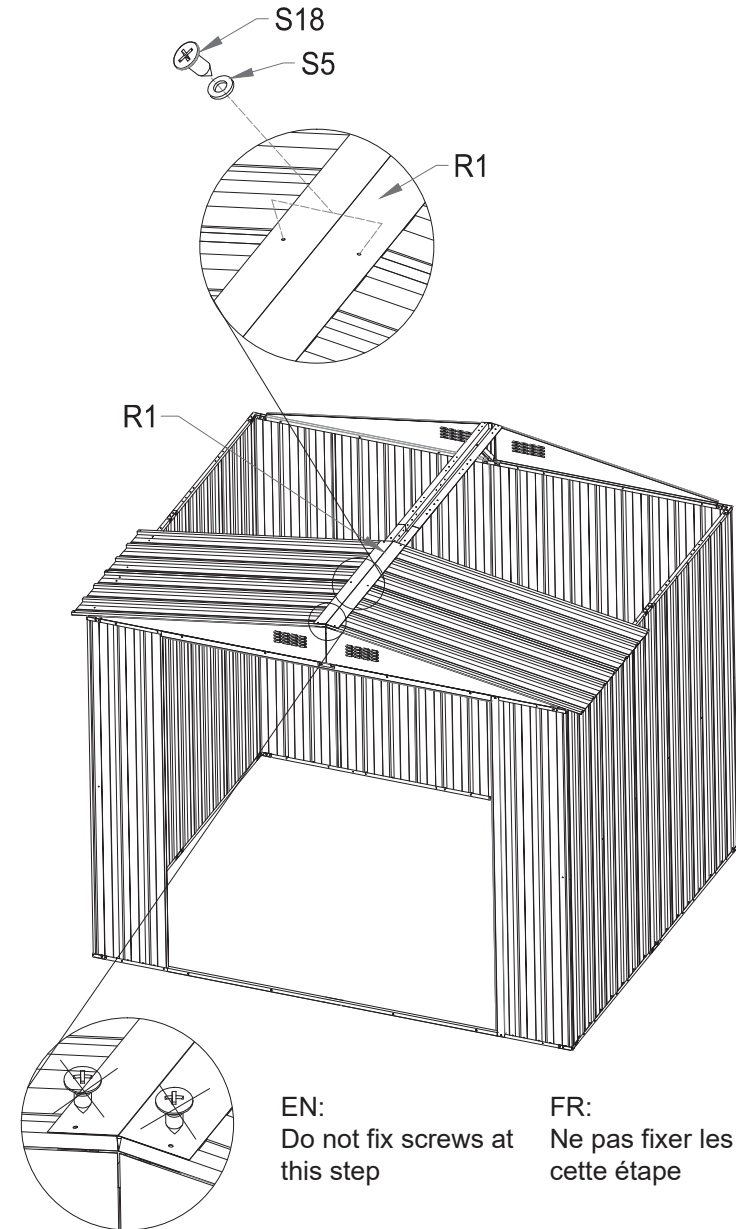

	R1	1		S18	2		S5	2
---	----	---	---	-----	---	---	----	---



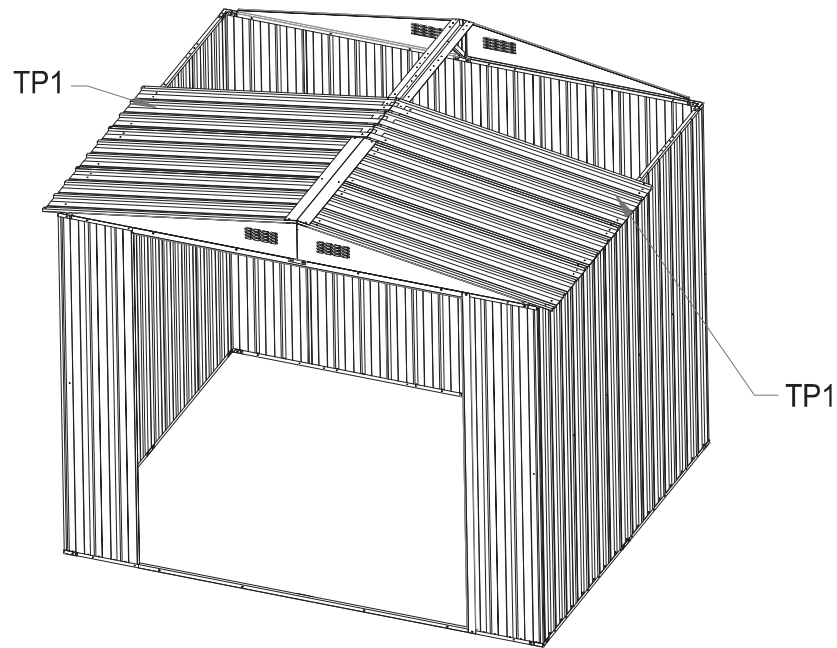

	TP1	2		S18	8		S5	8
---	-----	---	---	-----	---	---	----	---



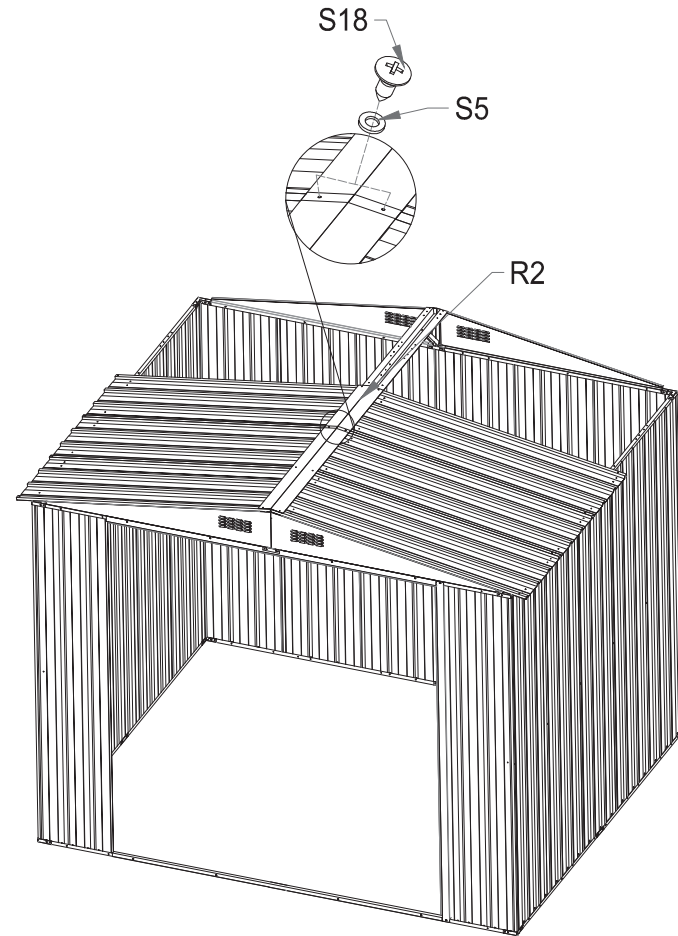



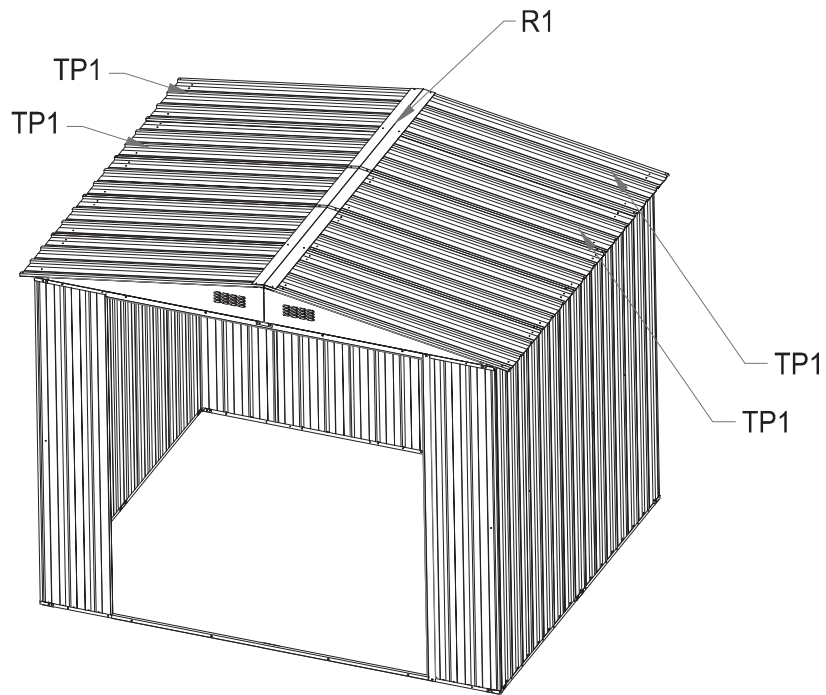

	R2	1		S18	2		S5	2
---	----	---	---	-----	---	---	----	---



	TP1	4		S18	20		R1	1
---	-----	---	---	-----	----	---	----	---









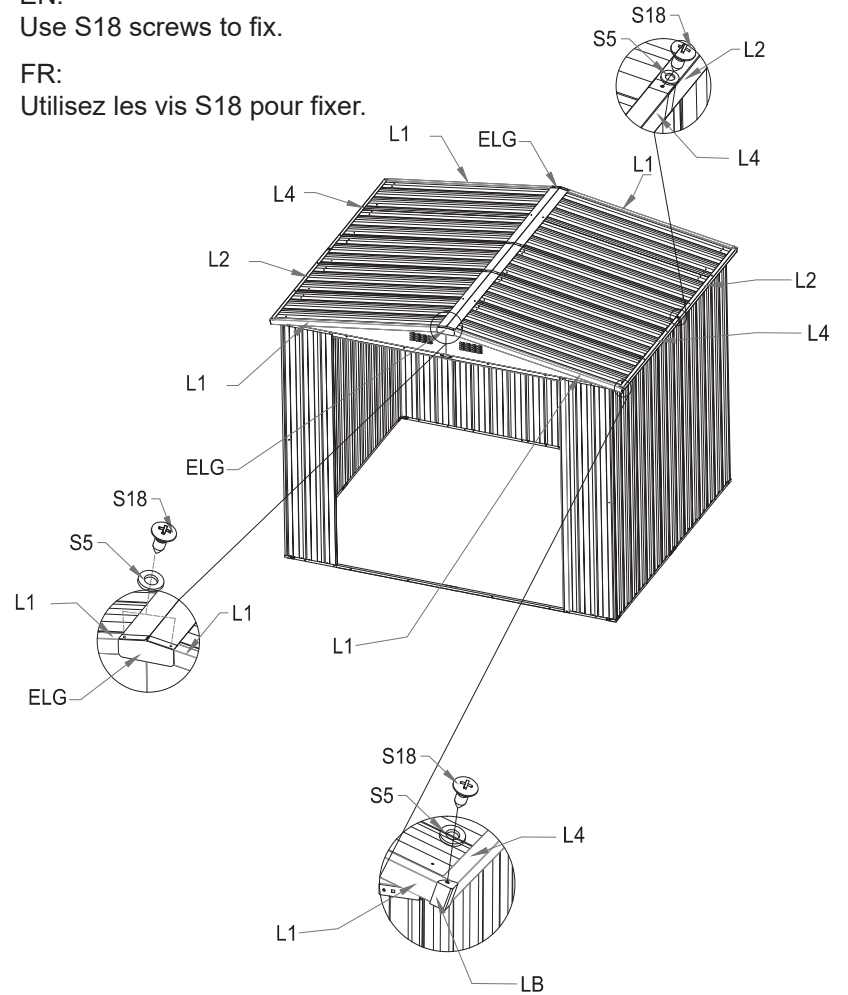



	L1	4		L2	2		L4	2
	S5	18		LB	4			
	ELG	2		S18	18			

EN:
Use S18 screws to fix.

FR:
Utilisez les vis S18 pour fixer.



	DP1	1		DT1	2		DF2	1
	DF3	1		D1	2		H2	1
	D2	1		S18	20		DP2	1
	H3	1		S5	10			

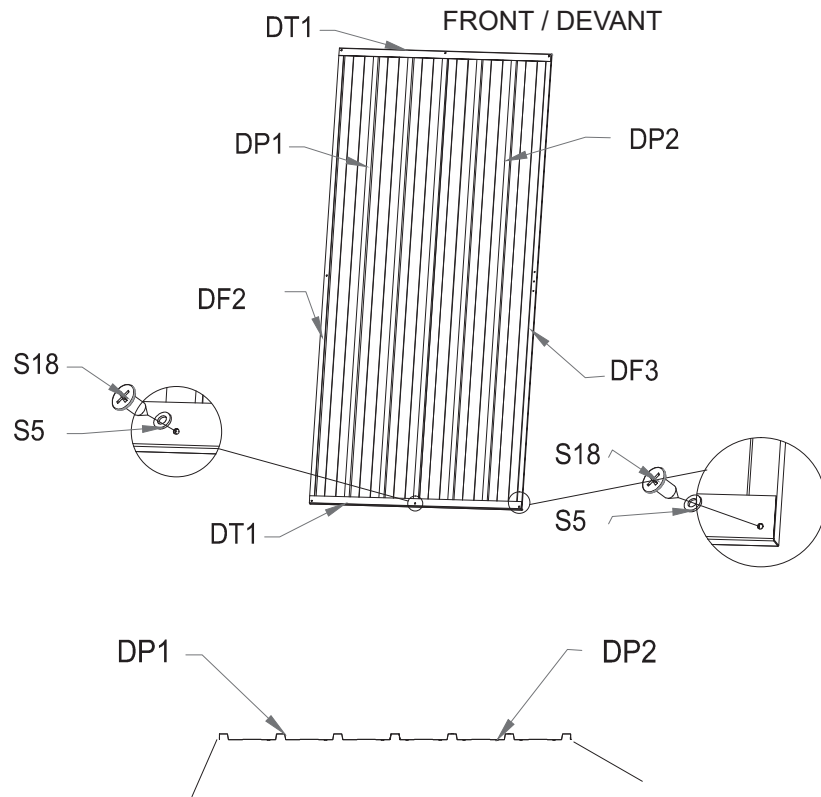





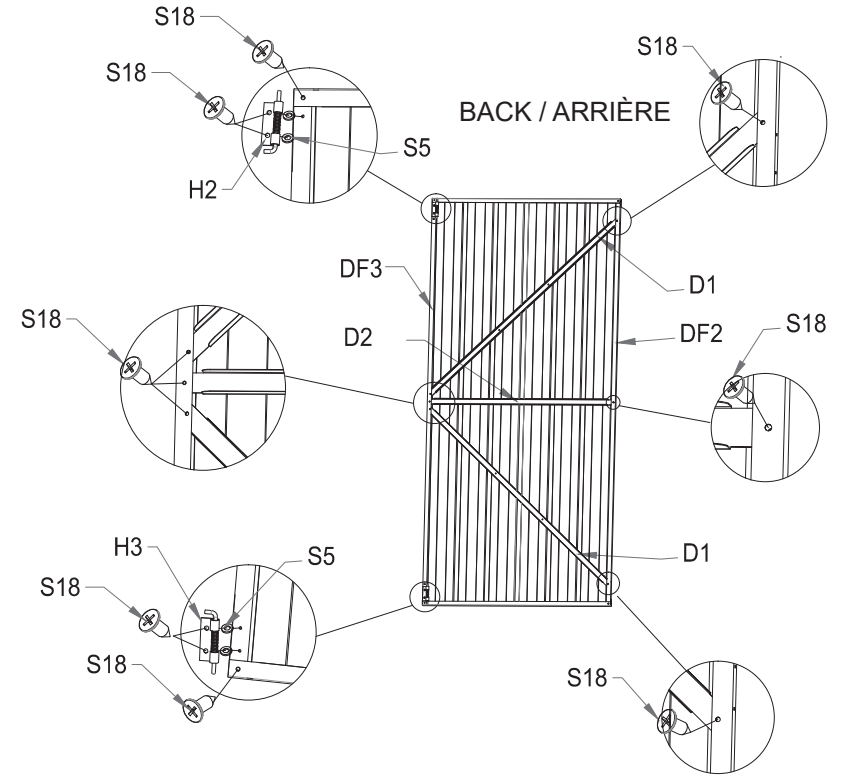

EN:
Right angled side
FR:
Côté à angle droit

EN:
Right angled side
FR:
Côté à angle droit



**SHED ASSEMBLY
LEFT DOOR**





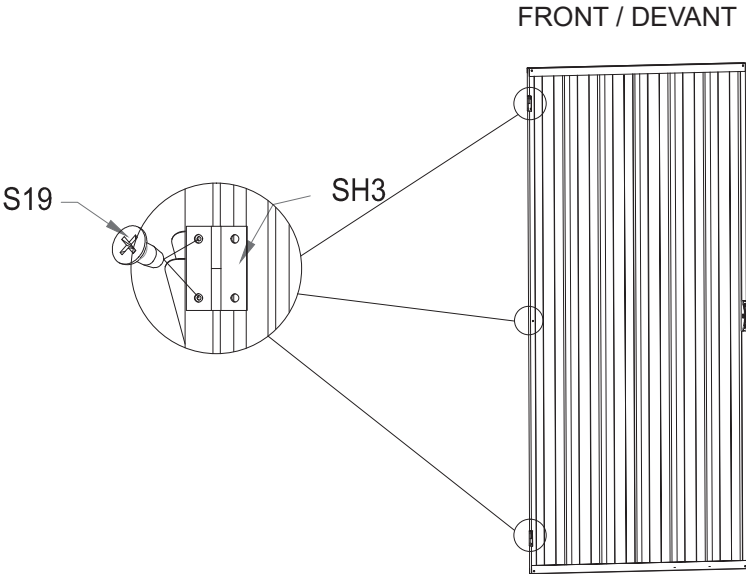
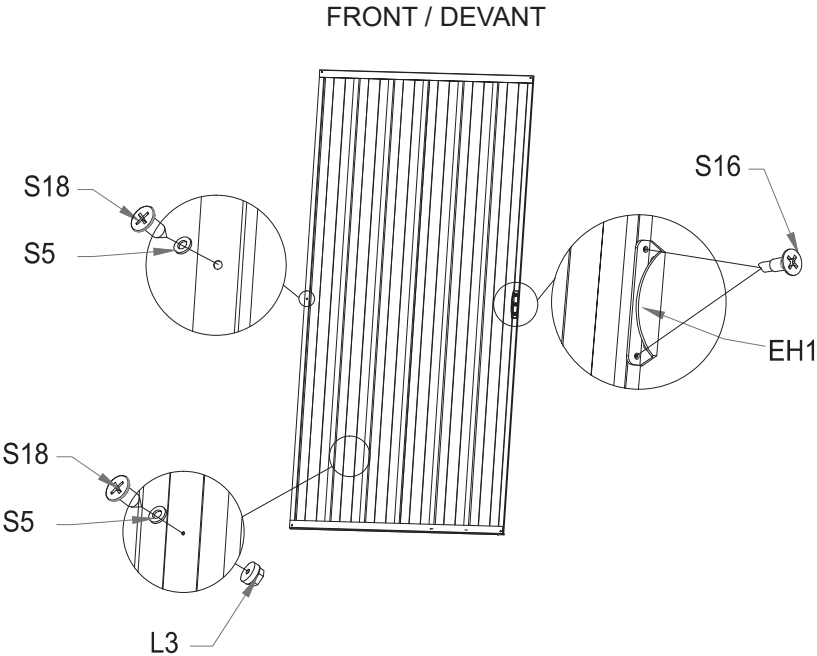



**ASSEMBLAGE DE
L'ABRI PANNEAU
DE TOIT**

	EH1	1		SH3	3		S19	6
	S16	2		S18	5			
	S5	5		L3	4			



SHED ASSEMBLY LEFT DOOR





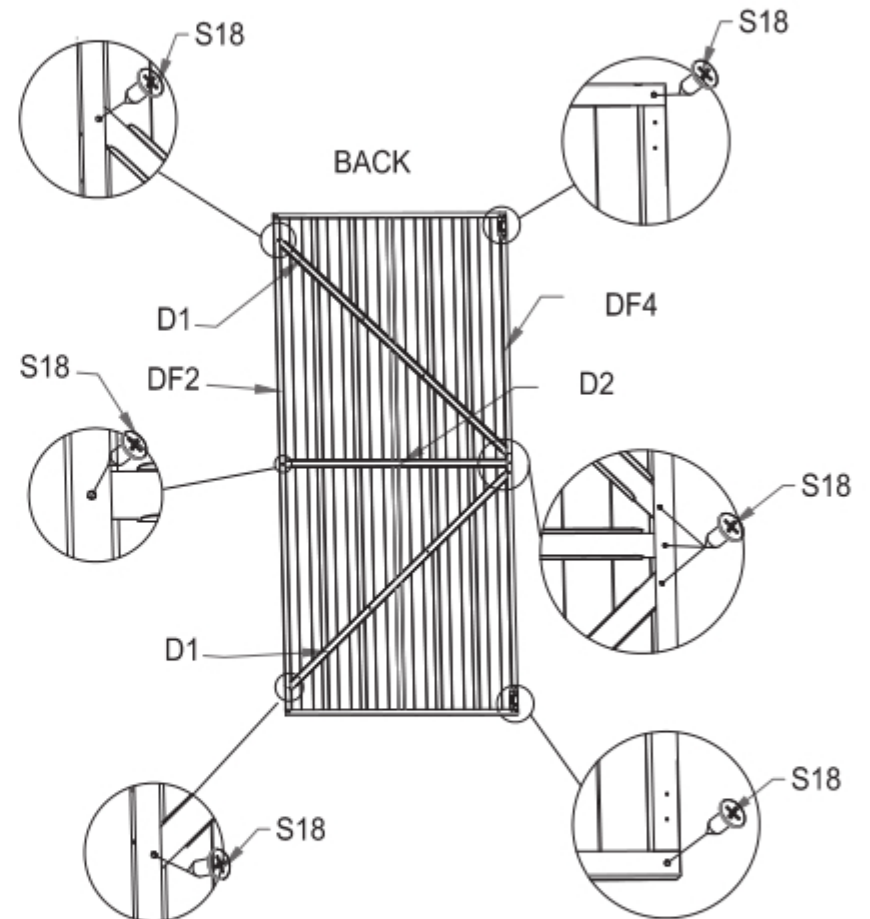
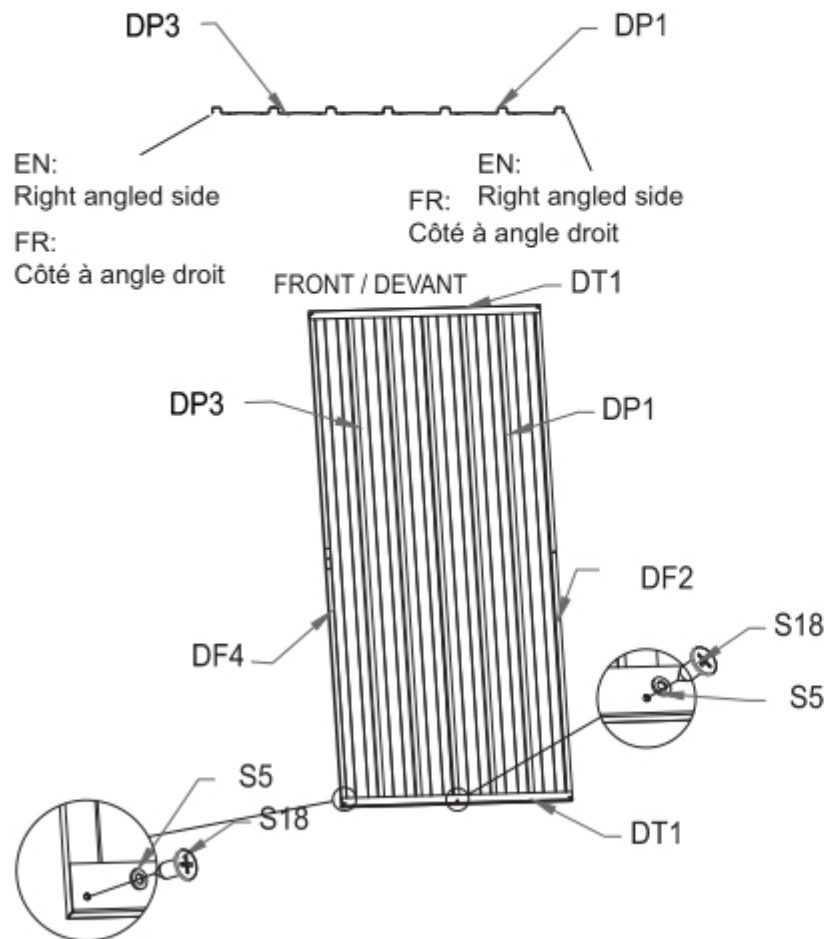

ASSEMBLAGE DE L'ABRI PANNEAU DE TOIT

	DP1	1		DT1	2		DF2	1
	DF4	1		D1	2		D2	1
	S18	16		DP3	1		S5	6



SHED ASSEMBLY RIGHT DOOR

COMMENT JOINDRE LES CANALISATIONS (si nécessaire)

	EH1	1		SH3	3		S19	6
	S5	5		L3	4			
	S16	2		S18	5			

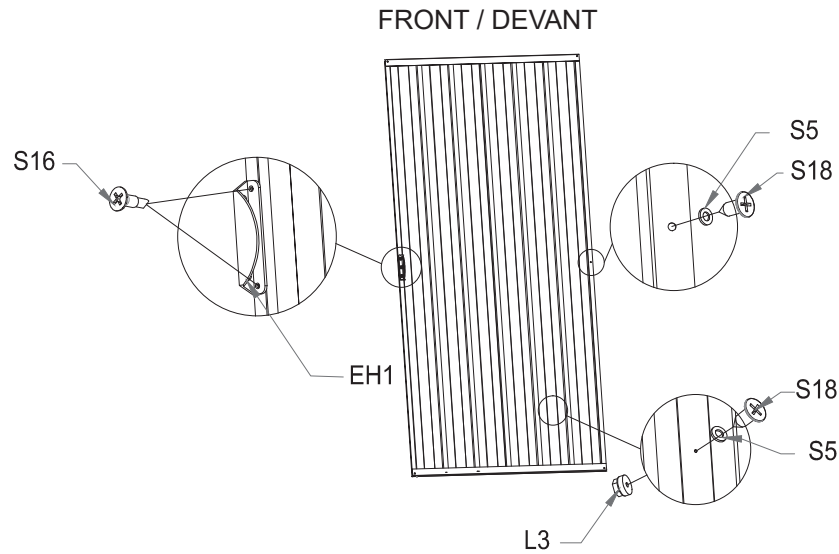

FRONT / DEVANT

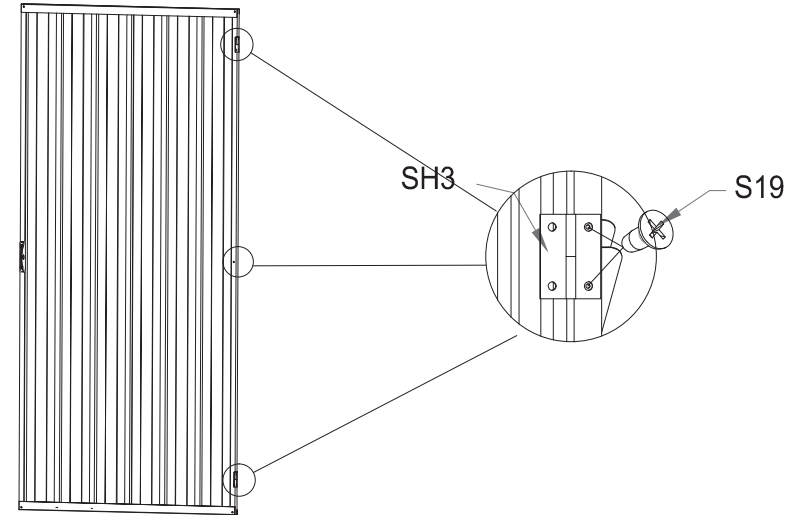

**SHED ASSEMBLY
FRONT DOOR**

**COMMENT
JOINDRE LES
CANALISATIONS
(si nécessaire)**

	ED3	1		S18	2
---	-----	---	---	-----	---

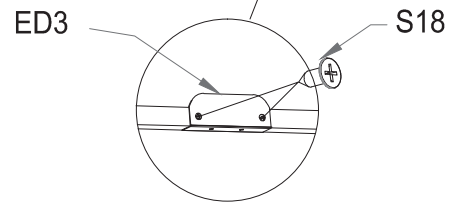
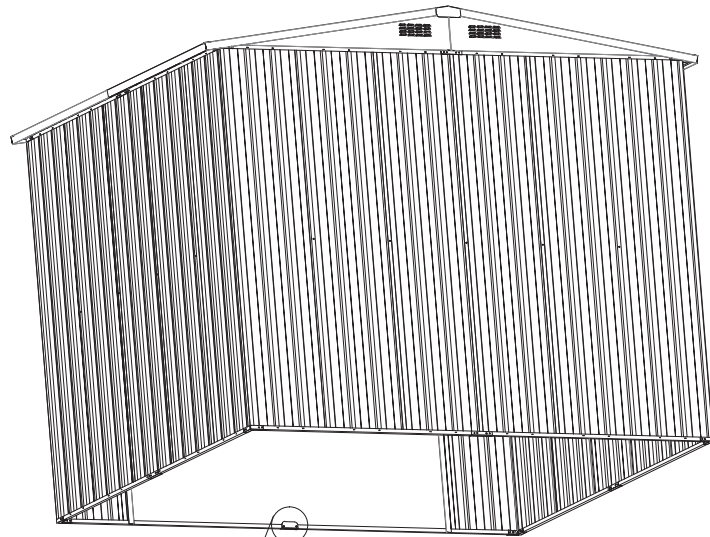

	S19	12
---	-----	----

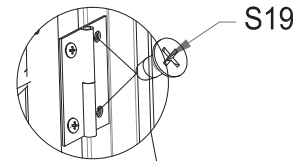
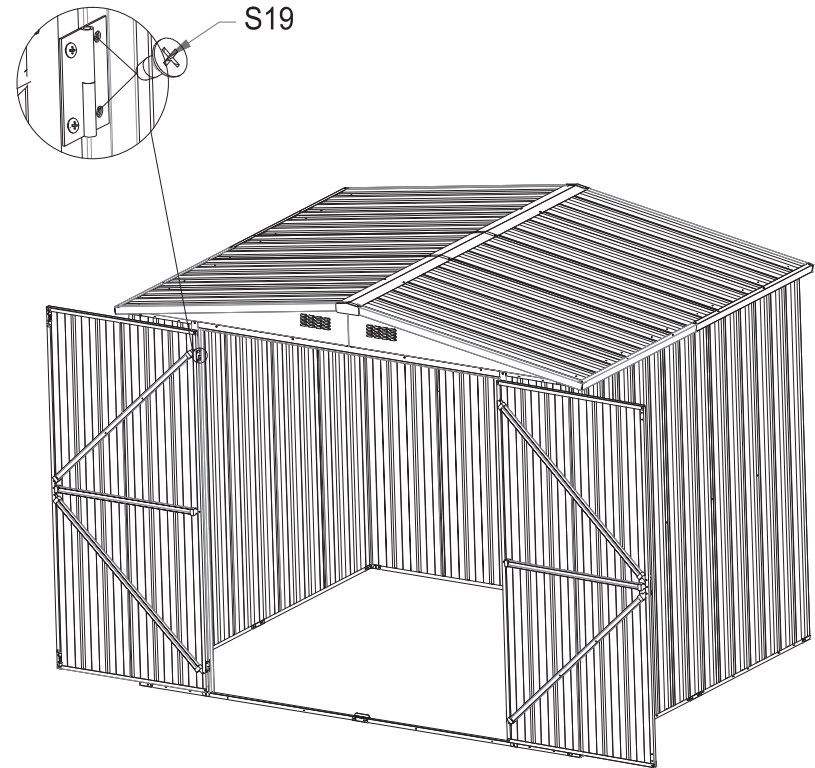

PROTECTION / PROTECTION

	L3	45
---	----	----

EN:
Use L3 screw protection cap
to cover screws on the beam
and wall.

FR:
Utilisez le capuchon de
protection de vis L3 pour
couvrir les vis de la poutre et
du mur.

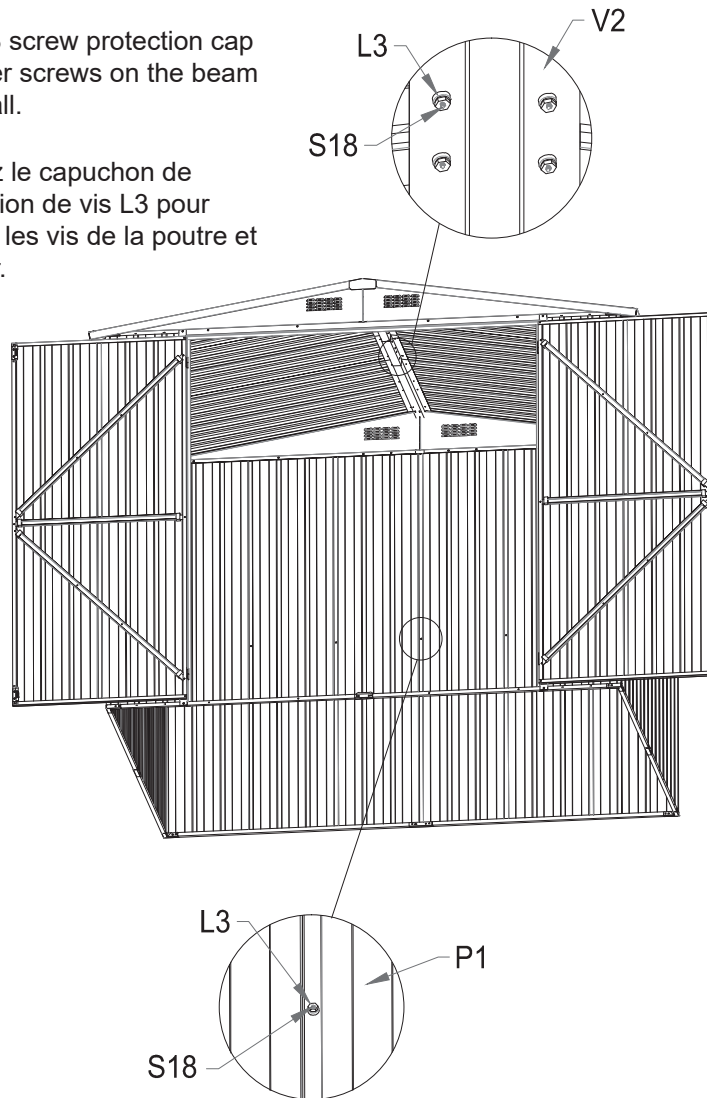

EN



Return / Damage Claim Instructions

- ⚠ **DO NOT discard the box / original packaging.**
In case a return is required, the item must be returned in original box. Without this your return will not be accepted.
- ⚠ **Take a photo of the box markings.**
A photo of the markings (text) on the side of the box is required in case a part is needed for replacement. This helps our staff identify your product number to ensure you receive the correct parts.
- ⚠ **Take a photo of the damaged part (if applicable).**
A photo of the damage is always required to file a claim and get your replacement or refund processed quickly. Please make sure you have the box even if it is damaged.
- ⚠ **Send us an email with the images requested.**
Email us directly from marketplace where your item was purchased with the attached images and a description of your claim.

FR



Instructions De Retour / Réclamation De Dommages

- ⚠ **NE PAS jeter la boîte/l'emballage d'origine.**
Dans le cas où un retour est requis, l'article doit être retourné dans sa boîte d'origine. Sans cela, votre retour ne sera pas accepté.
- ⚠ **Prenez une photo des marquages de la boîte.**
Une photo des marquages (texte) sur le côté de la boîte est requise au cas où une pièce serait nécessaire pour le remplacement. Cela aide notre personnel à identifier votre numéro de produit pour s'assurer que vous recevez les bonnes pièces.
- ⚠ **Prenez une photo des dommages (le cas échéant).**
Une photo des dommages est toujours requise pour déposer une réclamation et obtenir rapidement votre remplacement ou votre remboursement. Assurez-vous d'avoir la boîte même si elle est endommagée.
- ⚠ **Envoyez-nous un e-mail avec les images demandées.**
Envoyez-nous un e-mail directement depuis le marché où votre article a été acheté avec les images ci-jointes et une description de votre réclamation.