



Nightstand with Charging Station  
Table de Chevet avec Station de Charge

**HU10500US-CF**

USA office: Fontana   AUS office: Truganina   GBR office: Ipswich   FRA office: Saint Vigor d'Ymonville

If you're having difficulty, our friendly customer team is always here to help.









USA:cs.us@costway.com  
AUS:cs.au@costway.com  
GBR:cs.uk@costway.com  
FRA:cs.fr@costway.com

THIS INSTRUCTION BOOKLET CONTAINS **IMPORTANT** SAFETY INFORMATION. PLEASE READ AND KEEP FOR FUTURE REFERENCE.

EN









## Before You Start

-  Please read all instructions carefully.
-  Retain instructions for future reference.
-  Separate and count all parts and hardware.
-  Read through each step carefully and follow the proper order.
-  We recommend that, where possible, all items are assembled near to the area in which they will be placed in use, to avoid moving the product unnecessarily once assembled.
-  Always place the product on a flat, steady and stable surface.
-  Keep all small parts and packaging materials for this product away from babies and children as they potentially pose a serious choking hazard.

FR



## Avant de Commencer

-  Veuillez lire attentivement toutes les instructions.
-  Conservez les instructions pour vous y référer ultérieurement.
-  Vérifiez toutes les pièces et les accessoires.
-  Lisez attentivement chaque étape et suivez l'ordre correct.
-  Nous recommandons que, dans la mesure du possible, tous les produits soient assemblés à proximité de la zone où ils seront utilisés, afin d'éviter tout déplacement inutile du produit une fois assemblé.
-  Placez toujours le produit sur une surface plane et stable.
-  Conservez toutes les petites pièces de ce produit et les matériaux d'emballage hors de portée des bébés et des enfants, car ils pourraient présenter un risque d'étouffement.

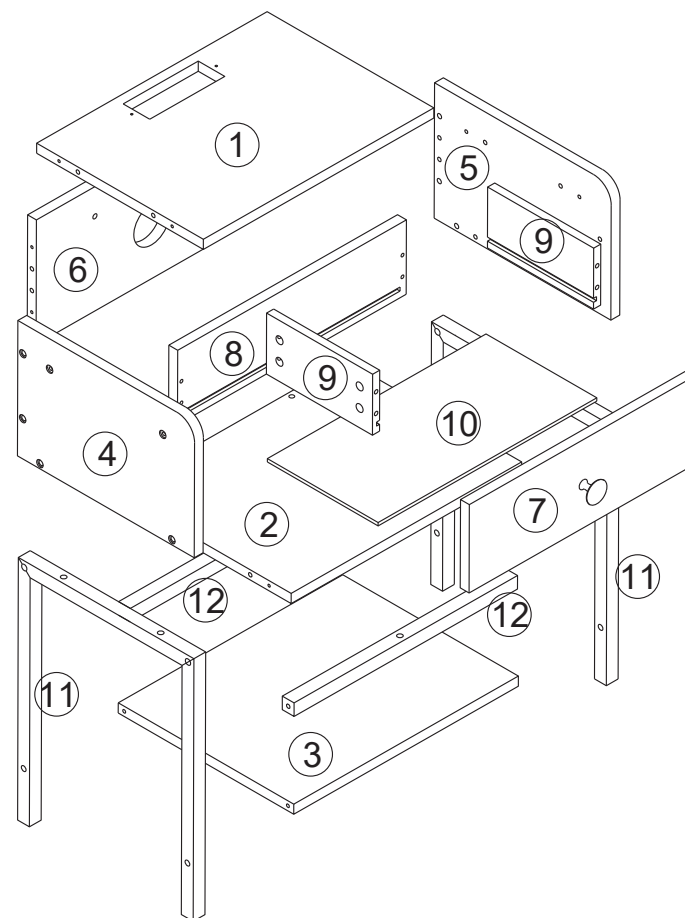

① x1

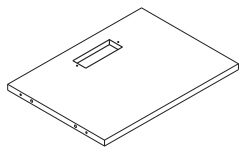

② x1

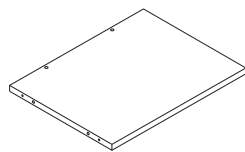

③ x1

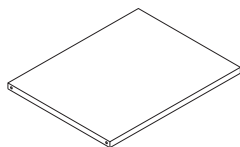

④ x1

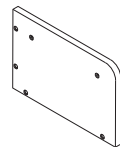

⑤ x1

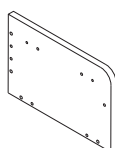

⑥ x1

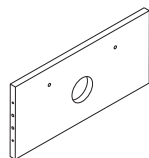

⑦ x1

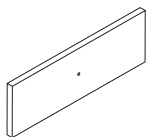

⑧ x1

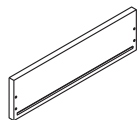

⑨ x2



⑩ x1

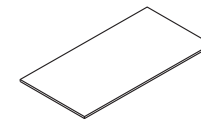

⑪ x2

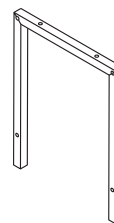

⑫ x2

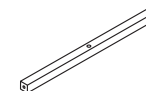

Ac



M6\*30

x2

Ad



M6\*35

x4

An

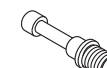

x8

Ao



x8

At



x1

Ba



x2

Bb



x4

Bn



Φ6\*30

x12

E



M3.5\*14

x2

F



M4\*22

x1

L



M7\*38



x24



Z

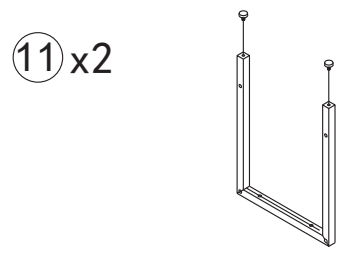
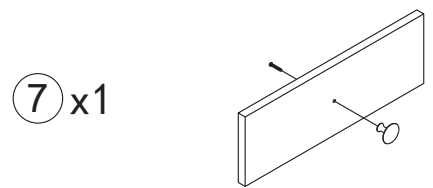
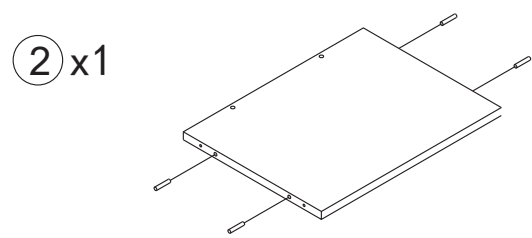
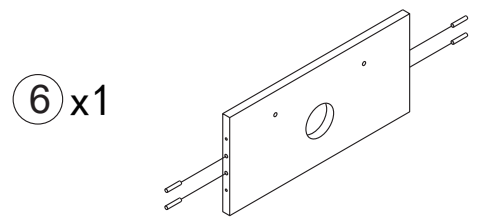
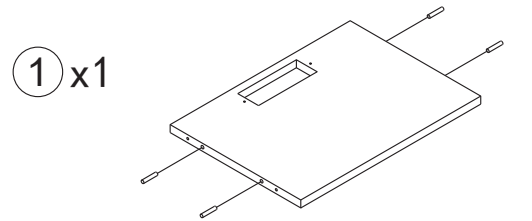

x24



<b>Bb</b>  x4
<b>Bn</b>  Φ6*30 x12
 M4*22 x1

<b>L</b>  M7*38 x4
<b>Ad</b>  M6*35 x4

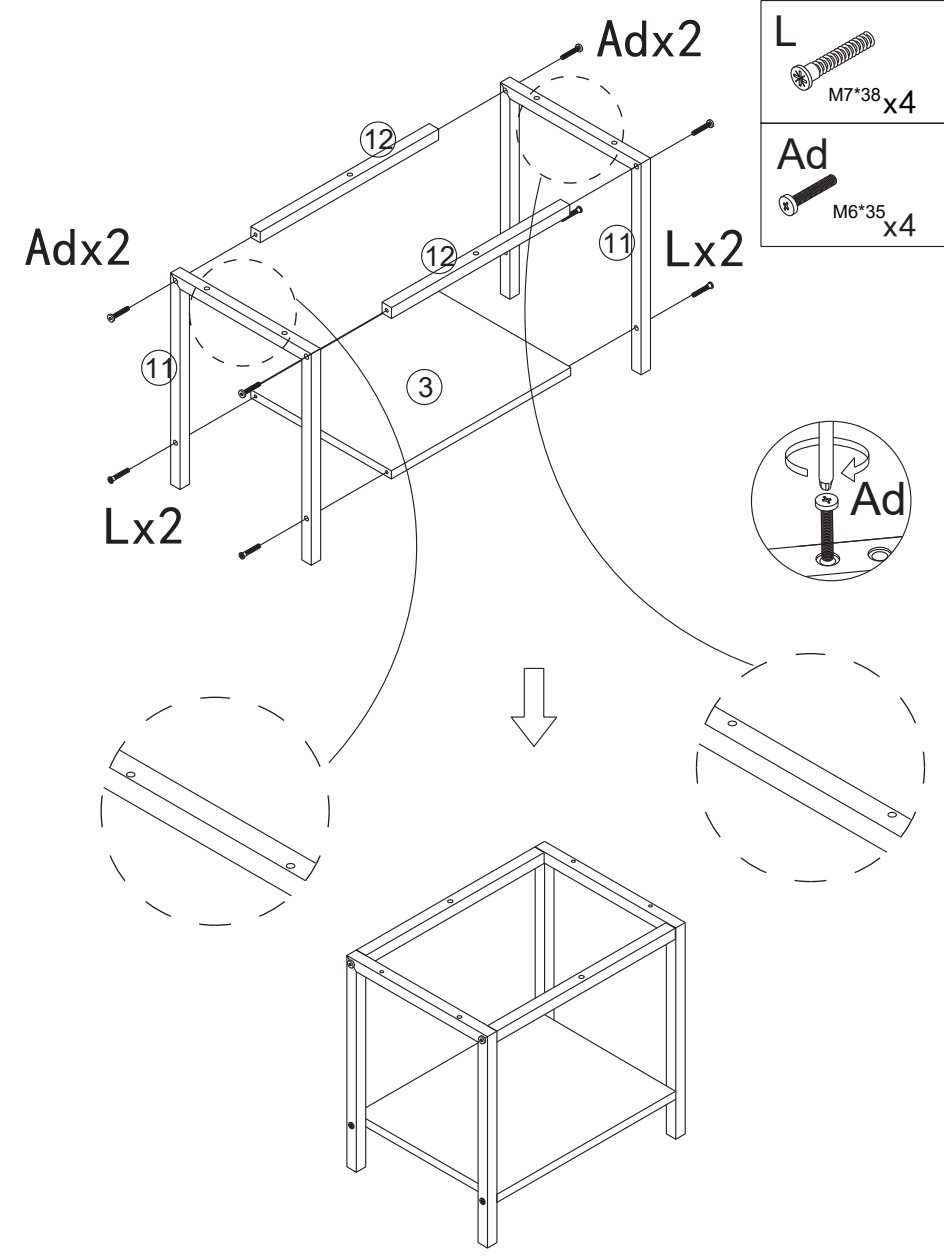

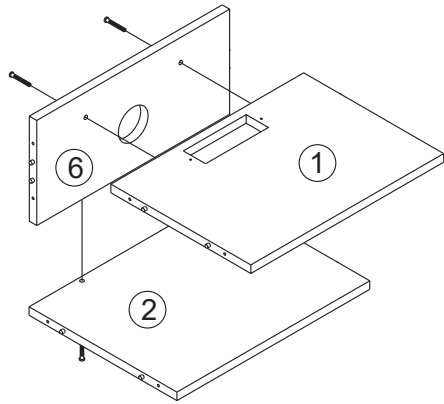
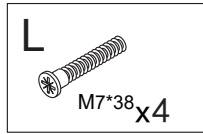

Lx4

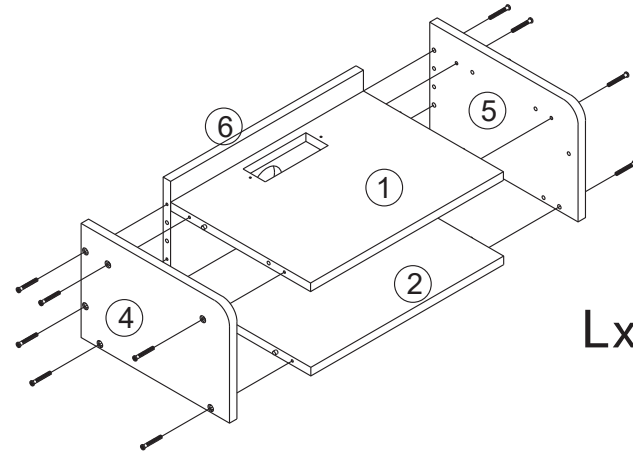
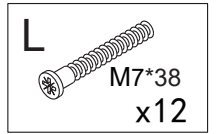
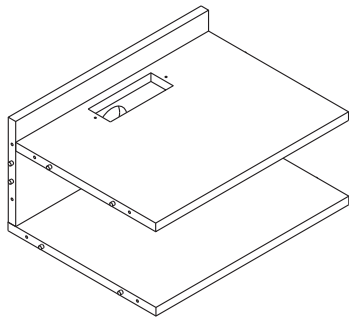
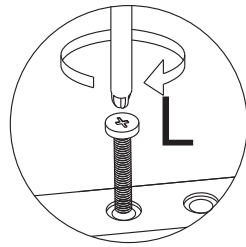

Lx12

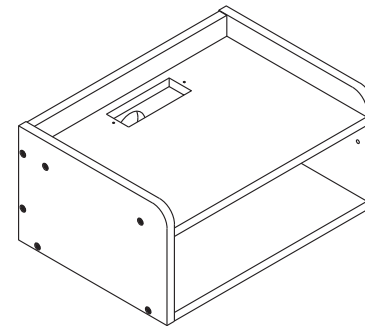
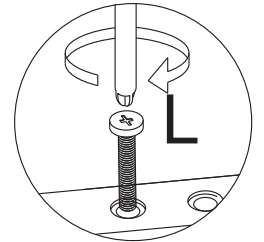

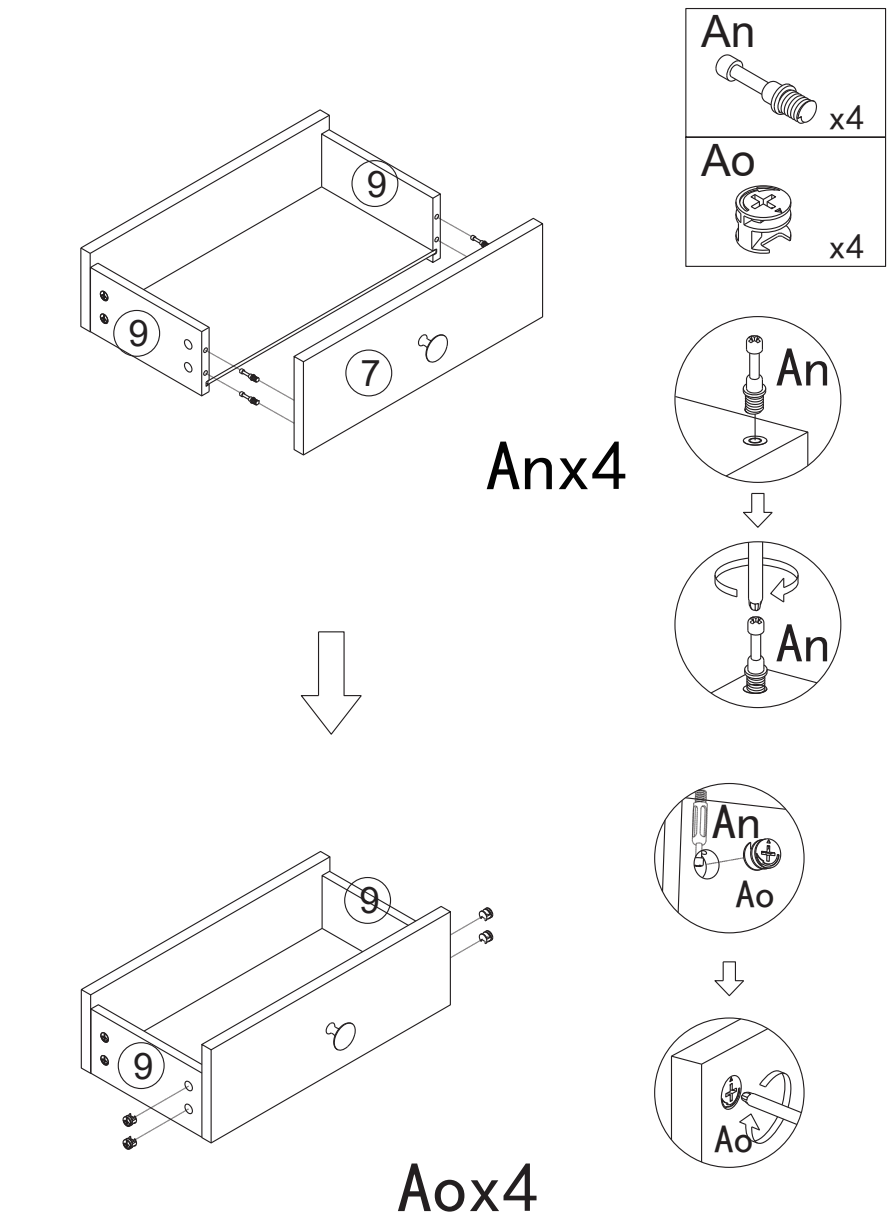
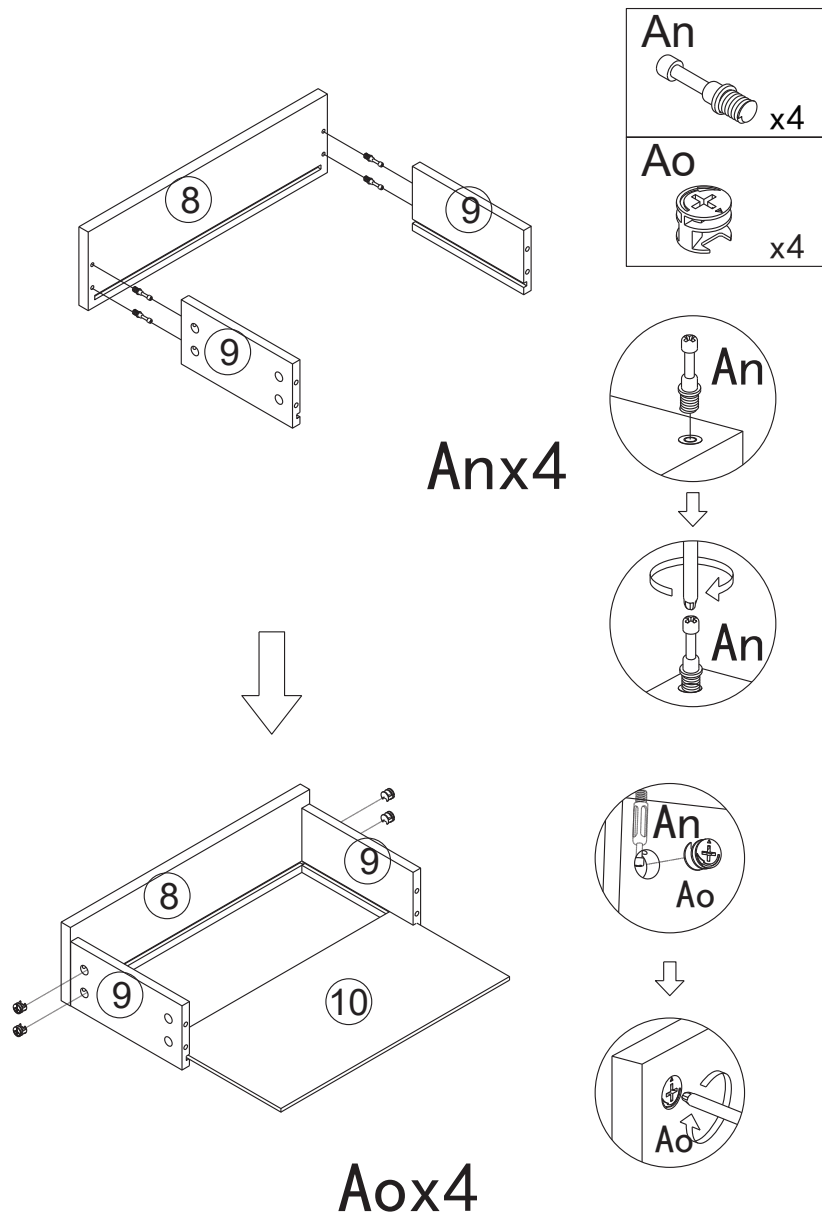

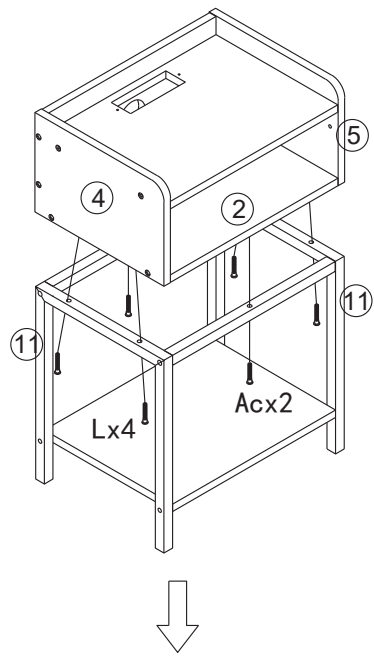

- Ac** M6\*30 x2
- L** M7\*38 x4
- Ba** x2
- Z** x24

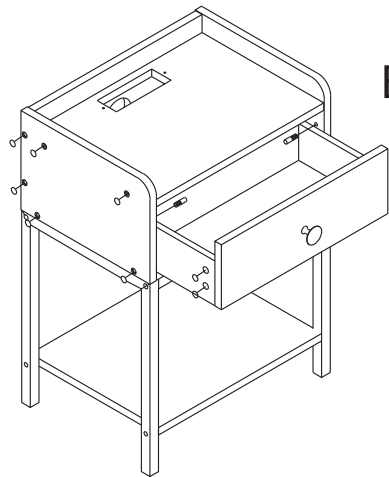
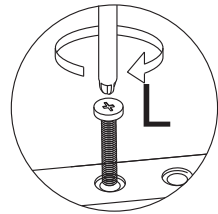

**Bax2**

**Zx24**

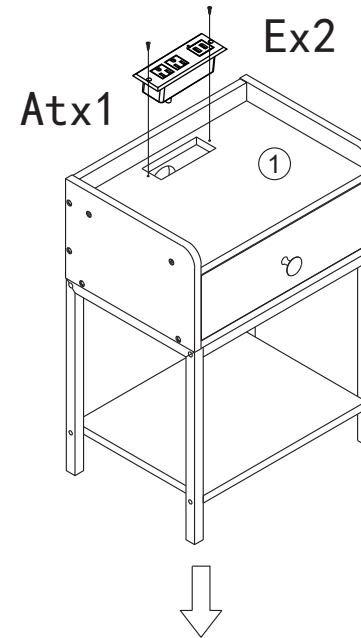
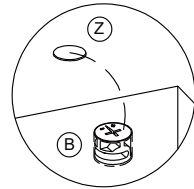

- At** x1
- E** M3.5\*14 x2

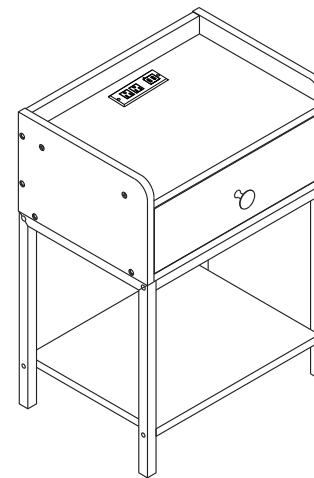
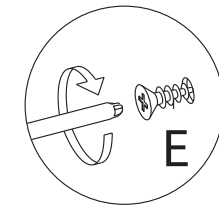

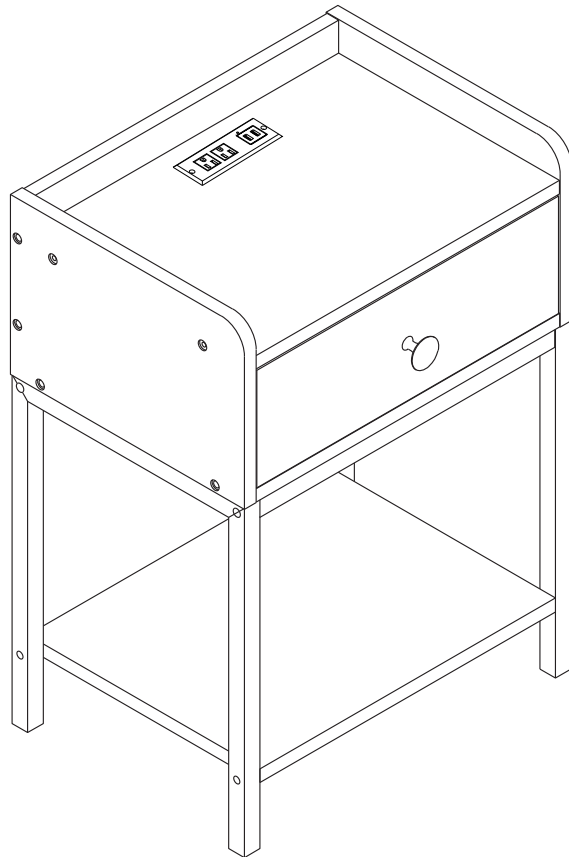





EN







### Return / Damage Claim Instructions

-  **DO NOT discard the box / original packaging.**  
In case a return is required, the item must be returned in original box. Without this your return will not be accepted.
-  **Take a photo of the box markings.**  
A photo of the markings (text) on the side of the box is required in case a part is needed for replacement. This helps our staff identify your product number to ensure you receive the correct parts.
-  **Take a photo of the damaged part (if applicable).**  
A photo of the damage is always required to file a claim and get your replacement or refund processed quickly. Please make sure you have the box even if it is damaged.
-  **Send us an email with the images requested.**  
Email us directly from marketplace where your item was purchased with the attached images and a description of your claim.

FR



### Instructions De Retour / Réclamation De Dommages

-  **NE PAS jeter la boîte/l'emballage d'origine.**  
Dans le cas où un retour est requis, l'article doit être retourné dans sa boîte d'origine. Sans cela, votre retour ne sera pas accepté.
-  **Prenez une photo des marquages de la boîte.**  
Une photo des marquages (texte) sur le côté de la boîte est requise au cas où une pièce serait nécessaire pour le remplacement. Cela aide notre personnel à identifier votre numéro de produit pour s'assurer que vous recevez les bonnes pièces.
-  **Prenez une photo des dommages (le cas échéant).**  
Une photo des dommages est toujours requise pour déposer une réclamation et obtenir rapidement votre remplacement ou votre remboursement. Assurez-vous d'avoir la boîte même si elle est endommagée.
-  **Envoyez-nous un e-mail avec les images demandées.**  
Envoyez-nous un e-mail directement depuis le marché où votre article a été acheté avec les images ci-jointes et une description de votre réclamation.