

Bookshelf  
Bibliothèque  
**JV12411**

THIS INSTRUCTION BOOKLET CONTAINS **IMPORTANT** SAFETY INFORMATION.  
PLEASE READ AND KEEP FOR FUTURE REFERENCE.

EN



## Before You Start

- ⚠ Please read all instructions carefully.
- ⚠ Retain instructions for future reference.
- ⚠ Separate and count all parts and hardware.
- ⚠ Read through each step carefully and follow the proper order.
- ⚠ We recommend that, where possible, all items are assembled near to the area in which they will be placed in use, to avoid moving the product unnecessarily once assembled.
- ⚠ Always place the product on a flat, steady and stable surface.
- ⚠ Keep all small parts and packaging materials for this product away from babies and children as they potentially pose a serious choking hazard.

FR



## Avant de Commencer

- ⚠ Veuillez lire attentivement toutes les instructions.
- ⚠ Conservez les instructions pour vous y référer ultérieurement.
- ⚠ Vérifiez toutes les pièces et les accessoires.
- ⚠ Lisez attentivement chaque étape et suivez l'ordre correct.
- ⚠ Nous recommandons que, dans la mesure du possible, tous les produits soient assemblés à proximité de la zone où ils seront utilisés, afin d'éviter tout déplacement inutile du produit une fois assemblé.
- ⚠ Placez toujours le produit sur une surface plane et stable.
- ⚠ Conservez toutes les petites pièces de ce produit et les matériaux d'emballage hors de portée des bébés et des enfants, car ils pourraient présenter un risque d'étouffement.

# PART LIST / LISTE DES PIÈCES

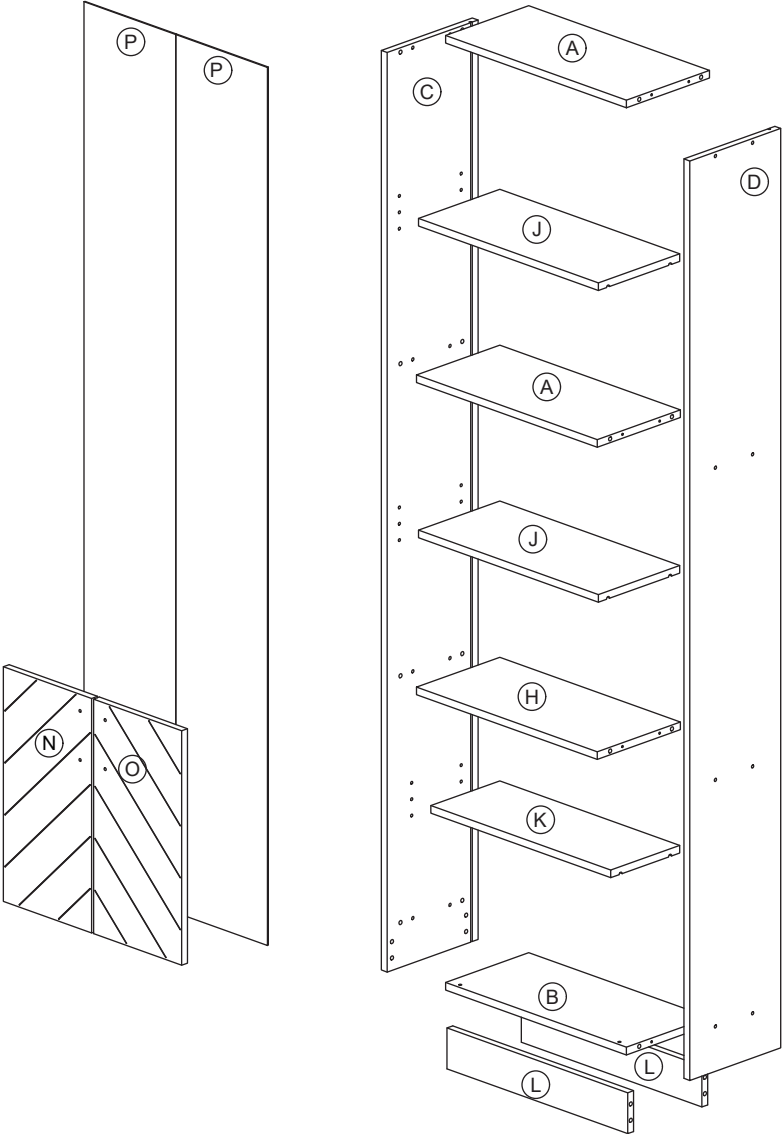

## Hardware List / Liste de Quincaillerie

---

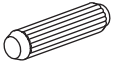

8x25mm  
Dowel/Cheville

① x24



M5x38mm  
Screw/Vis

② x16

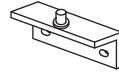

MT Stopper  
/Butée MT

③ x4



M3x16mm  
Screw/Vis

④ x8



Handle  
/Poignée

⑤ x2



M4x30mm  
Screw/Vis

⑥ x4



⑦ x2

Magnetic Catch  
Flat Head Tapping  
Screw M6 x 10mm  
/Loquet Magnétique  
Vis Autotaraudeuse à  
Tête Plate M6 X 10 mm



Shelf Support  
/Support d'Étagère

⑧ x12



Nail Leg  
/Pied de Clou

⑨ x4



Screw Hole Cover  
/Cache-trou de Vis

⑩ x16



Nail  
/Clou

⑪ x24

## Anti-tipping Kit / Dispositif Anti-basculement

---



M3.5x15mm  
Screw/Vis

Ⓡ1 x2

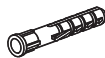

Wall Plug  
/Cheville Murale

Ⓡ2 x2



M4x30mm  
Screw/Vis

Ⓡ3 x2



Safety Strap  
/Sangle de Sécurité

Ⓡ4 x2



6x13x1mm  
Flat Washer  
/Rondelle Plate

Ⓡ5 x4

1

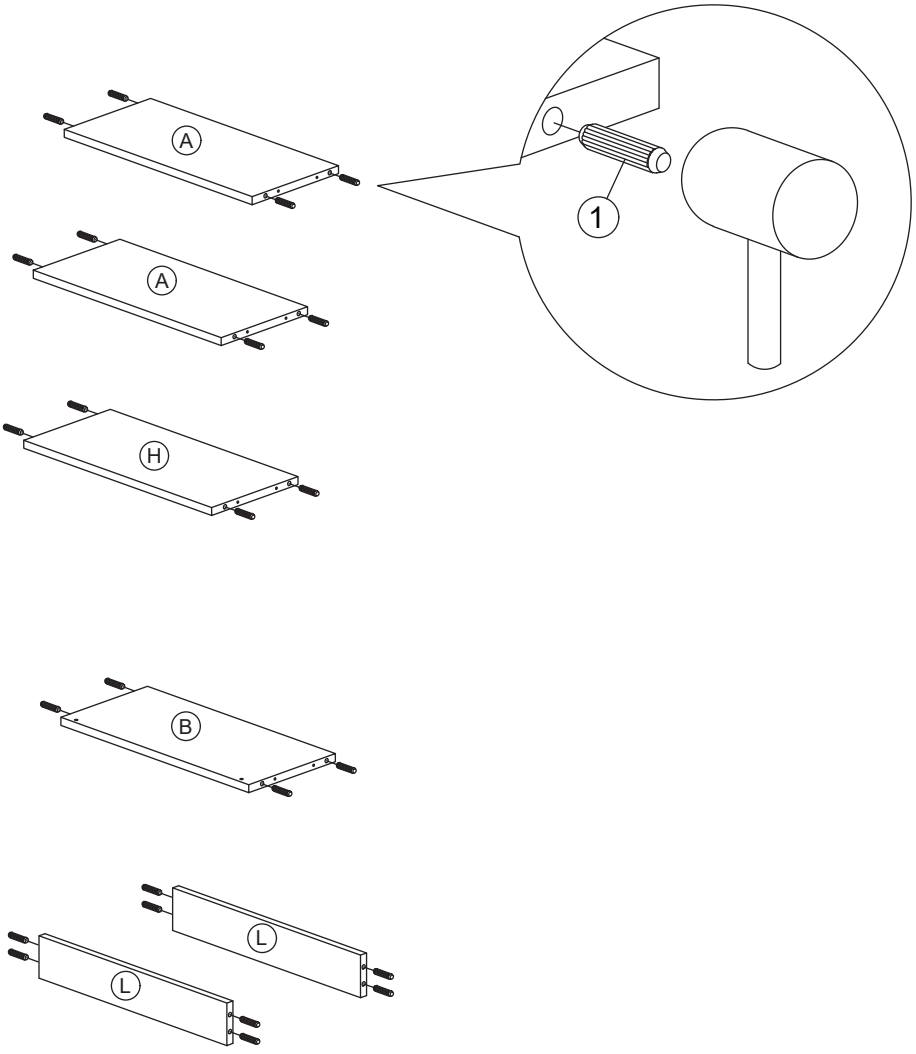

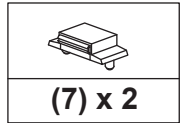
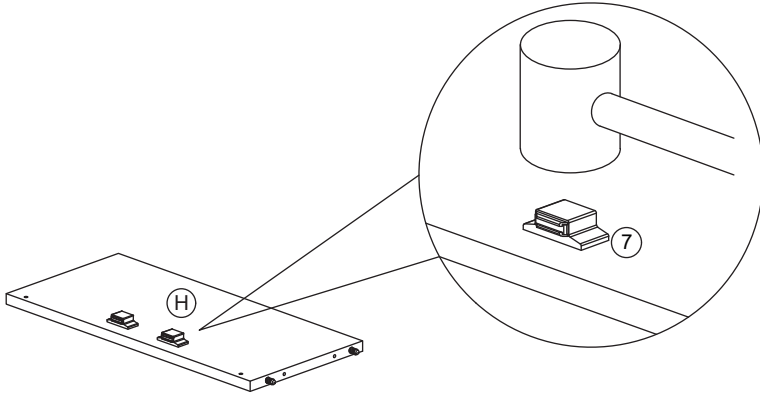

<b>(1) x 24</b>

2

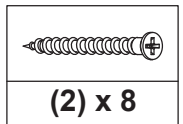
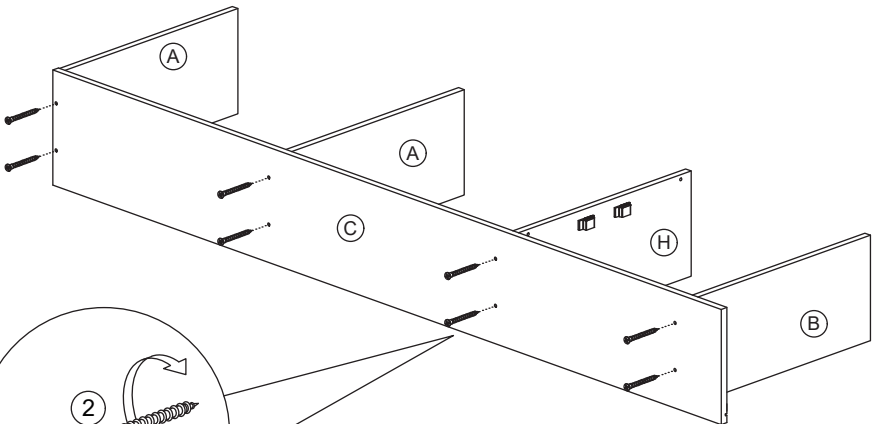

3



4

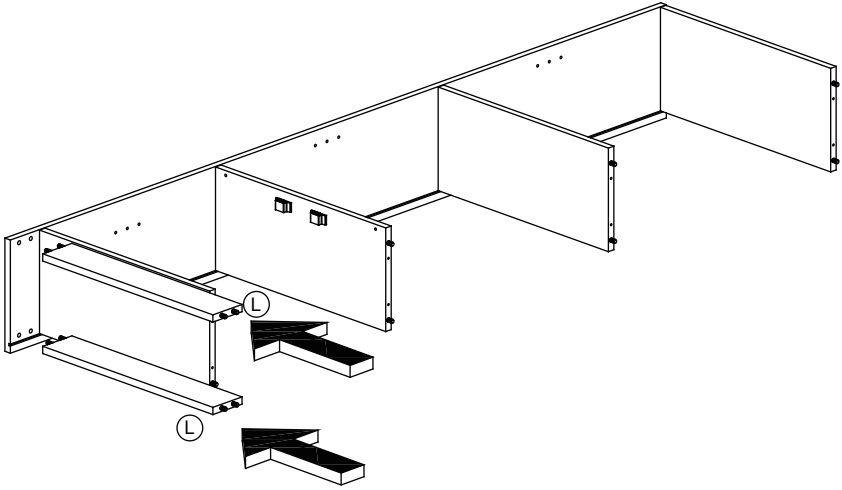

5

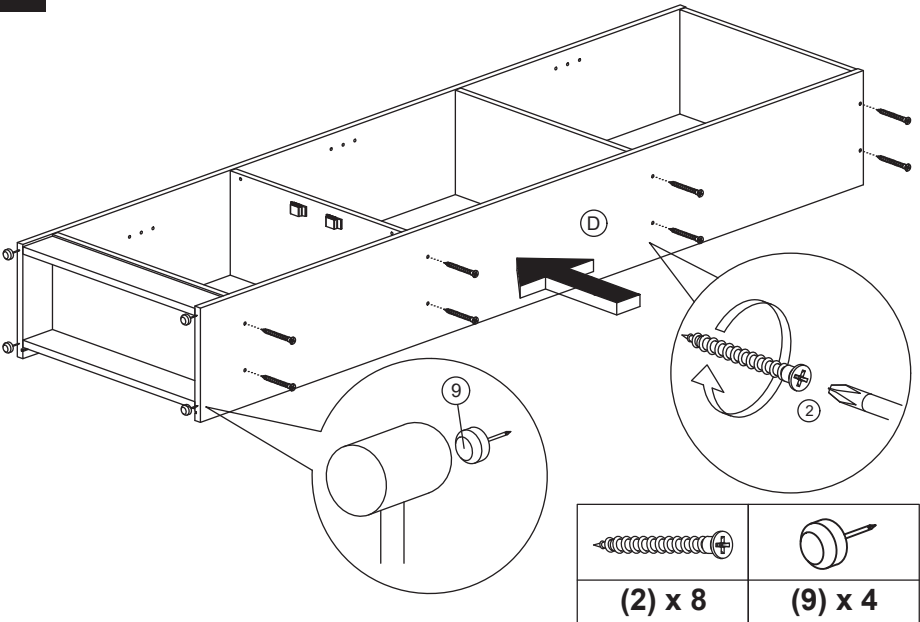

6

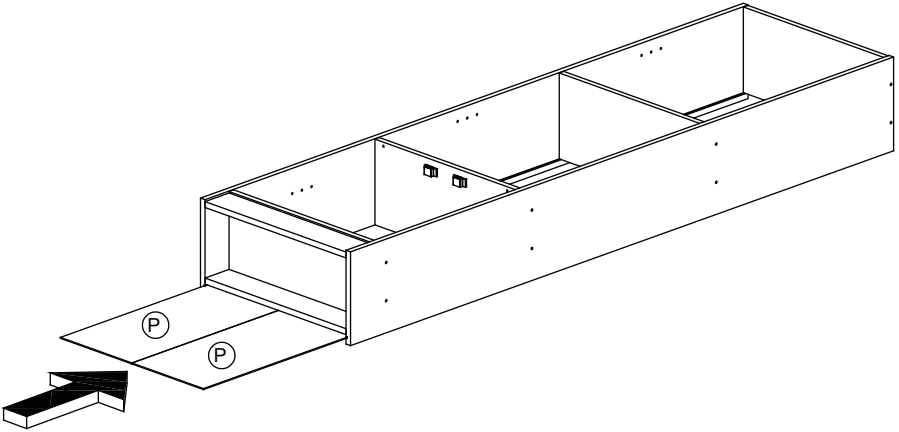

7

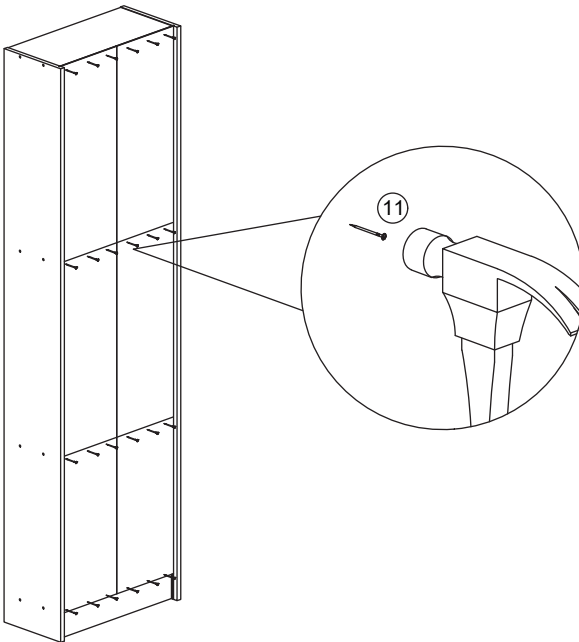

8

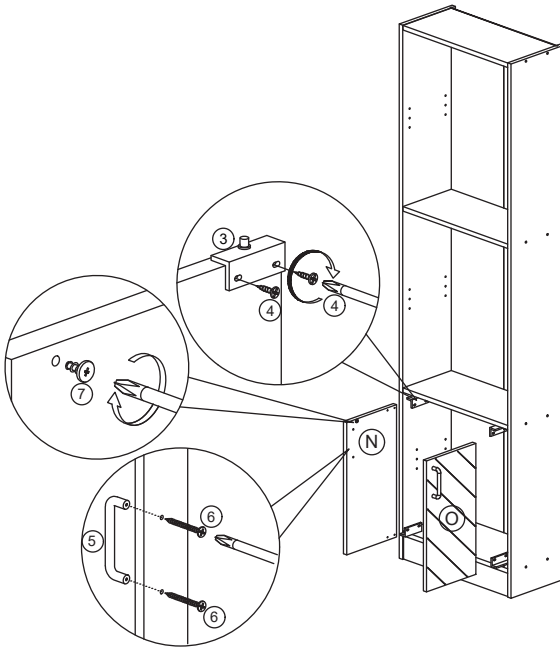

<b>(3) x 4</b>
<b>(4) x 8</b>
<b>(5) x 2</b>
<b>(6) x 4</b>
<b>(7) x 2</b>

9

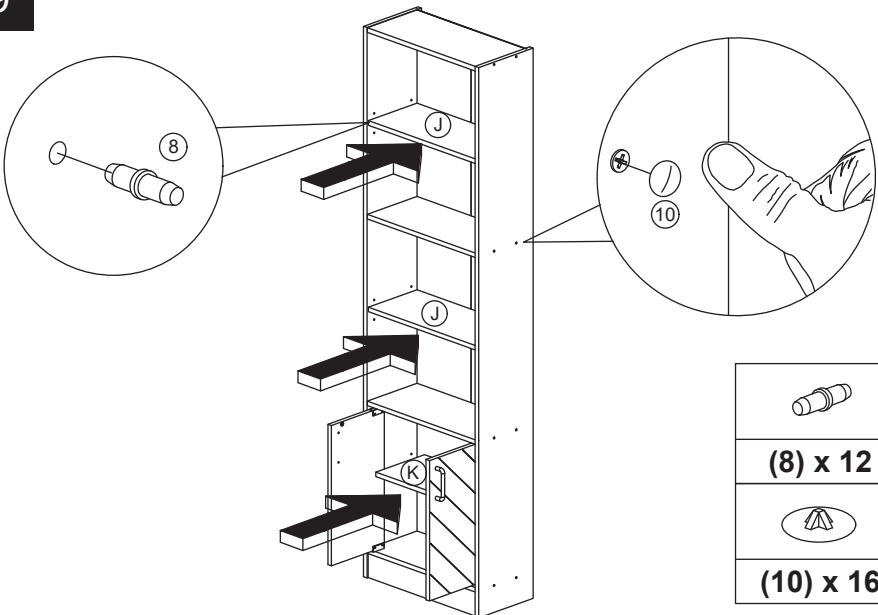

<b>(8) x 12</b>
<b>(10) x 16</b>

## Furniture Anti-tipping Kit Assembly /Assemblage du Kit Anti-basculement pour Meuble

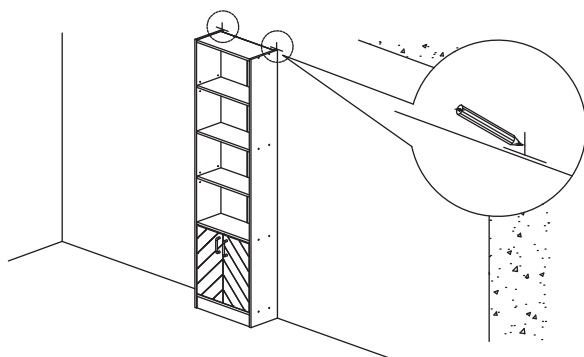

**EN**

1. First mark the wall with pencil as in diagram.

**FR**

1. Marquez d'abord le mur avec un crayon comme sur le schéma.

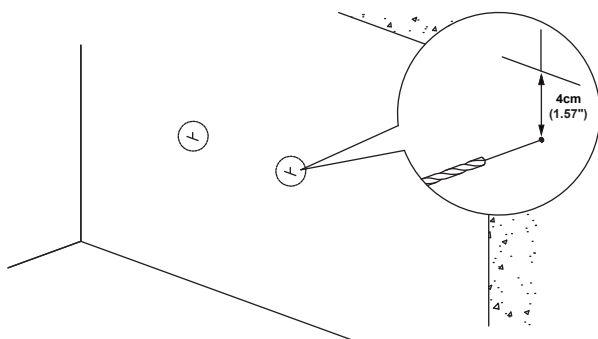

**EN**

2. Drill small hole at the pencil mark.

**FR**

2. Percez un petit trou au niveau de la marque au crayon.

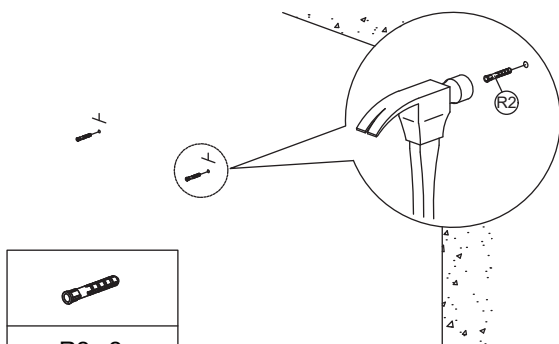

**EN**

3. Insert plastic wall plug (R2).

**FR**

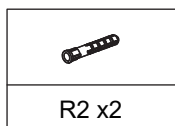

3. Insérez la cheville murale en plastique (R2).

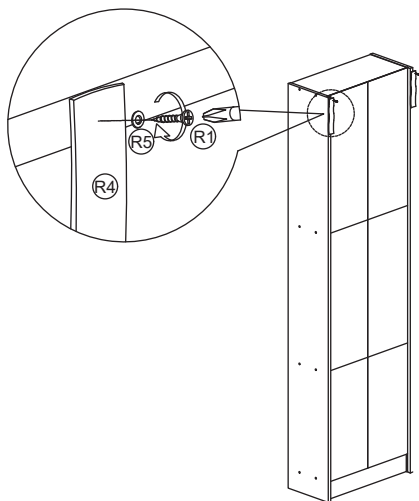



**EN** 4. Add safety strap (R4), washer (R5) using 3.5x15mm screw (R1) to back of product.

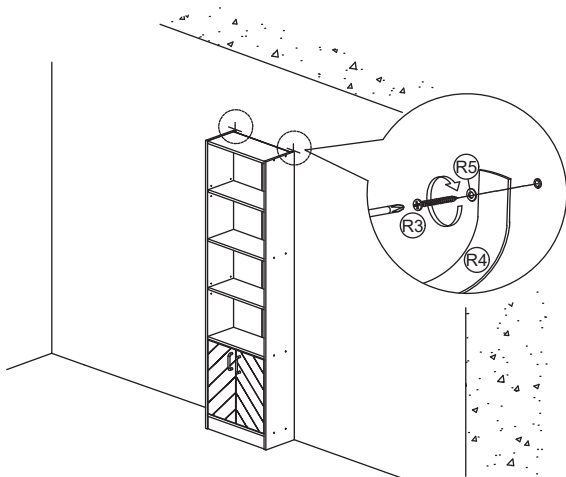

**FR** 4. Ajoutez la sangle de sécurité (R4), la rondelle (R5) à l'aide d'une vis 3,5x15 mm (R1) à l'arrière du produit.

 M3.5x15mm		
R1 x2	R4 x2	R5 x2



**EN** 5. Finally, attach safety strap (R4) and washer (R5) using 4x30mm screw (R3) to the wall.

**FR** 5. Enfin, fixez la sangle de sécurité (R4) et la rondelle (R5) à l'aide d'une vis 4x30 mm (R3) au mur.

 M4x30mm	
R3 x2	R5 x2

**EN** ANTI-TIPPING KIT is provided with the products and it is required for assembly, any accident occurs due to failing to fix the product with Anti-tipping is at your own risk

**FR** Le KIT ANTI-BASCULEMENT est fourni avec les produits et est nécessaire pour l'assemblage. Tout accident survenant en raison de la non-fixation du produit avec l'anti-basculement est à vos propres risques.

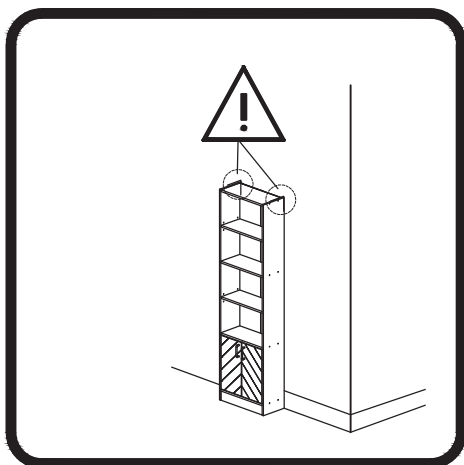

**EN**  Anti-tipping hardware included for added safety and stability.

**FR**  Kit anti-Basculement inclus pour plus de sécurité et de stabilité.

EN



## Return / Damage Claim Instructions

- ⚠ **DO NOT discard the box / original packaging.**  
In case a return is required, the item must be returned in original box. Without this your return will not be accepted.
- ⚠ **Take a photo of the box markings.**  
A photo of the markings (text) on the side of the box is required in case a part is needed for replacement. This helps our staff identify your product number to ensure you receive the correct parts.
- ⚠ **Take a photo of the damaged part (if applicable).**  
A photo of the damage is always required to file a claim and get your replacement or refund processed quickly. Please make sure you have the box even if it is damaged.
- ⚠ **Send us an email with the images requested.**  
Email us directly from marketplace where your item was purchased with the attached images and a description of your claim.

FR



## Instructions De Retour / Réclamation De Dommages

- ⚠ **NE PAS jeter la boîte/l'emballage d'origine.**  
Dans le cas où un retour est requis, l'article doit être retourné dans sa boîte d'origine. Sans cela, votre retour ne sera pas accepté.
- ⚠ **Prenez une photo des marquages de la boîte.**  
Une photo des marquages (texte) sur le côté de la boîte est requise au cas où une pièce serait nécessaire pour le remplacement. Cela aide notre personnel à identifier votre numéro de produit pour s'assurer que vous recevez les bonnes pièces.
- ⚠ **Prenez une photo des dommages (le cas échéant).**  
Une photo des dommages est toujours requise pour déposer une réclamation et obtenir rapidement votre remplacement ou votre remboursement. Assurez-vous d'avoir la boîte même si elle est endommagée.
- ⚠ **Envoyez-nous un e-mail avec les images demandées.**  
Envoyez-nous un e-mail directement depuis le marché où votre article a été acheté avec les images ci-jointes et une description de votre réclamation.

**USA** office: Fontana

**AUS** office: Truganina

**FRA** office: Saint Vigor d'Ymonville

**GBR** office: FDS Corporation Limited, Unit 4, Blackacre Road, Great Blakenham, Ipswich, Ip6 0FL, United Kingdom

If you're having difficulty, our friendly customer team is always here to help.



USA: [cs.us@costway.com](mailto:cs.us@costway.com)  
AUS: [cs.au@costway.com](mailto:cs.au@costway.com)  
GBR: [cs.uk@costway.com](mailto:cs.uk@costway.com)  
FRA: [cs.fr@costway.com](mailto:cs.fr@costway.com)