

Rattan Daybed and Stool
Canapé 2 Places en Rotin avec Repose-Pieds

HW71627

USA office: Fontana AUS office: Truganina GBR office: Ipswich FRA office: Saint Vigor d'Ymonville

If you're having difficulty, our friendly customer team is always here to help.



USA:cs.us@costway.com
AUS:cs.au@costway.com
GBR:cs.uk@costway.com
FRA:cs.fr@costway.com

EN



Before You Start

- ⚠ Please read all instructions carefully.
- ⚠ Retain instructions for future reference.
- ⚠ Separate and count all parts and hardware.
- ⚠ Read through each step carefully and follow the proper order.
- ⚠ We recommend that, where possible, all items are assembled near to the area in which they will be placed in use, to avoid moving the product unnecessarily once assembled.
- ⚠ Always place the product on a flat, steady and stable surface.
- ⚠ Keep all small parts and packaging materials for this product away from babies and children as they potentially pose a serious choking hazard.

FR



Avant de Commencer

- ⚠ Veuillez lire attentivement toutes les instructions.
- ⚠ Conservez les instructions pour vous y référer ultérieurement.
- ⚠ Vérifiez toutes les pièces et les accessoires.
- ⚠ Lisez attentivement chaque étape et suivez l'ordre correct.
- ⚠ Nous recommandons que, dans la mesure du possible, tous les produits soient assemblés à proximité de la zone où ils seront utilisés, afin d'éviter tout déplacement inutile du produit une fois assemblé.
- ⚠ Placez toujours le produit sur une surface plane et stable.
- ⚠ Conservez toutes les petites pièces de ce produit et les matériaux d'emballage hors de portée des bébés et des enfants, car ils pourraient présenter un risque d'étouffement.

1 x Bench
/ 1 x Banquette

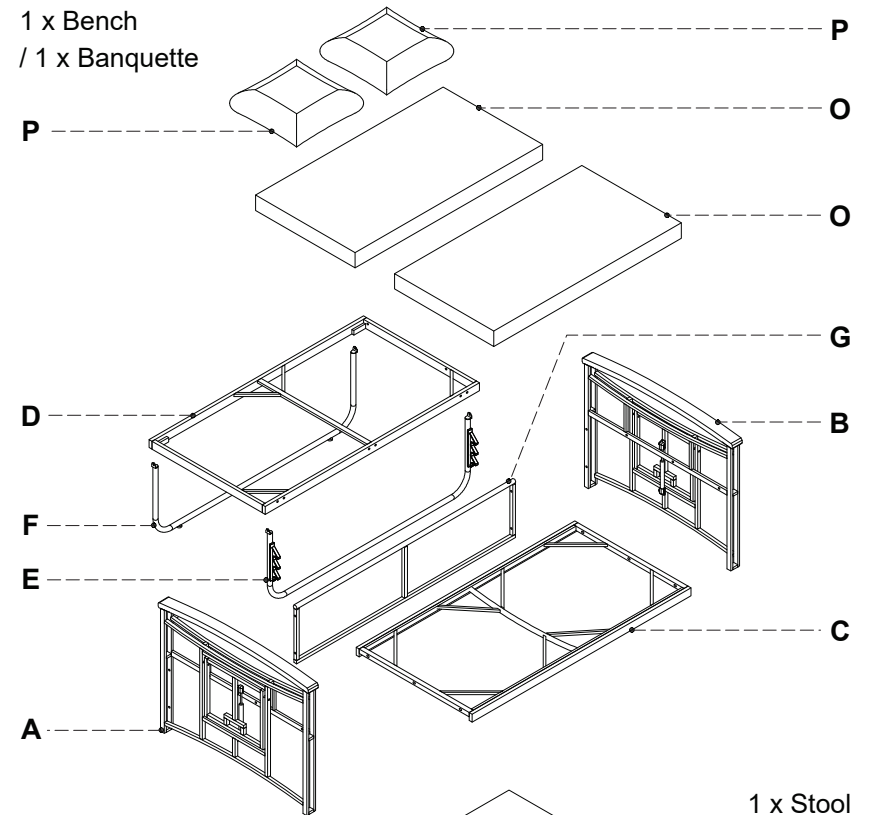

1 x Stool
/ 1 x Tabouret

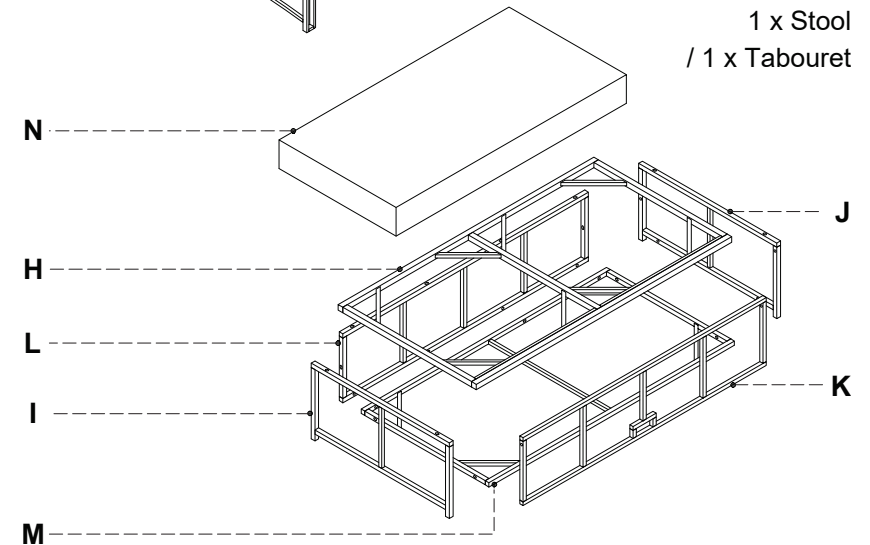

EN Notice

1. 50% tighten before fixing all screws, Allen wrench is recommended instead of an electric drill.
2. Place the item on a flat ground to adjust and make sure it remains stable.
3. Tighten up all screws with tools gradually.
4. If the screws are not aligned with holes during assembly, please loosen all the other screws to 50% and continue the assembly process.
5. If the item is not stable, please loosen all the screws, adjust it on a flat ground and tighten up all screws again.
6. **Note:** If one or some screws are fully tightened during assembly, the others may not be aligned with the holes. In addition, all the holes are designed to be relatively larger to provide more space for the adjustment of the screws.

FR Remarque

1. Serrez à 50 % avant de fixer toutes les vis, une clé Allen est recommandée au lieu d'une perceuse électrique.
2. Placez l'article sur un sol plat pour ajuster et assurez-vous qu'il reste stable.
3. Serrez progressivement toutes les vis avec des outils.
4. Si les vis ne sont pas alignées avec les trous lors de l'assemblage, veuillez desserrer toutes les autres vis à 50 % et poursuivre le processus d'assemblage.
5. Si l'article n'est pas stable, veuillez desserrer toutes les vis, l'ajuster sur un sol plat et resserrer toutes les vis.
6. **Remarque:** Si une ou plusieurs vis sont complètement serrées lors du montage, les autres peuvent ne pas être alignées avec les trous. De plus, tous les trous sont conçus pour être relativement plus grands afin de fournir plus d'espace pour le réglage des vis.

Parts List /Liste des Pièces

- (A) Arm Right Frame
/Marco
Derecho del
Brazo
x1

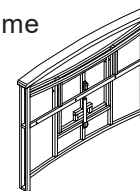

- (B) Arm Left
Frame
/Cadre de
l'Accoudoir
Gauche
x1

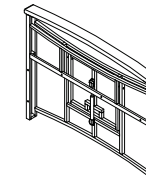

- (C) Bench Seat Frame
/Cadre de la Banquette
x1

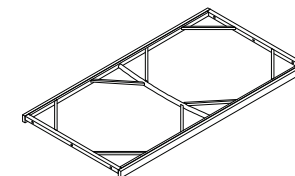

- (D) Bench Back Frame
/Cadre de Dossier de Banquette
x1

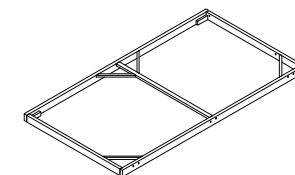

- (E) Hip Back Frame
/Cadre de Dossier
de Hanche
x1

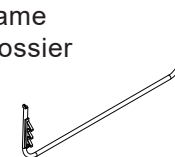

- (F) Hip Back Frame
/Cadre du Dossier
de Hanche
x1

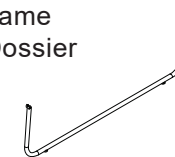

- (G) Bench Back side Frame
/Cadre du Dossier de Hanche
x1

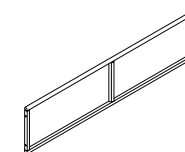

- H** Stool Seat Frame
/Cadre Lateral du Dossier de Banquette
x1

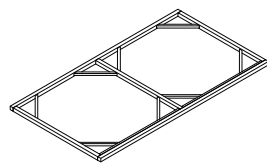

- I** Leg Right Stool
/Cadre Siege du Tabouret
x1

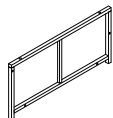

- J** Leg Left Stool
/Pieds du Tabouret Gauche
x1

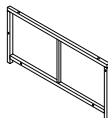

- K** Stool Front Side Frame
/Cadre Latéral Avant du Tabouret
x1

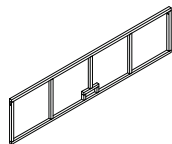

- L** Stool Back Side Frame
/Cadre Latéral Arriere du Tabouret
x1

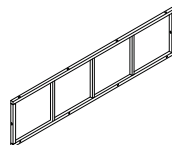

- M** Stool Shelf Frame
/Cadre de Support pour Tabouret
x1

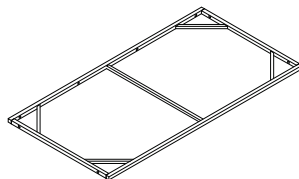

- N** Stool Seat Cushion
/Coussin de Siège de Tabouret
x1

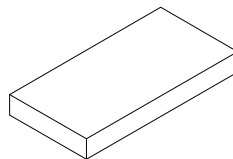

- O** Bench Seat & Back Cushion
/Coussin de Siege et de Dossier de Banquette
x2

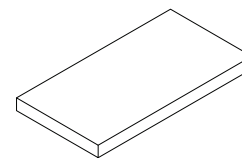

- P** Back Pillow
/Coussin de Dossier
x2



Hardware List /Liste des Accessoires

- 1** Bolt
/Boulon
x12



M6x15mm

- 2** Bolt
/Boulon
x4



M6x30mm

- 3** Bolt
/Boulon
x24

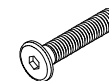

M6x35mm

- 4** Bolt
/Boulon
x6

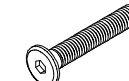

M6x40mm

- 5** Washers
/Rondelle
x34



Ø6x16x1mm

- 6** Washers
/Rondelle
x2



Ø6x16x5mm

- 7** Washers
/Rondelle
x4



Ø6x20x15mm

- 8** Hinge
/Charnière
x3

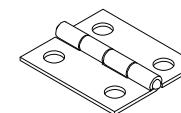

- 9** Allen key
/Clé Allen
x2

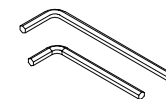

M4

1

(1 x Bench assembly /Assemblage de 1 x banquette)

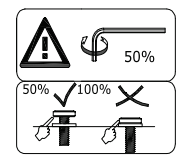
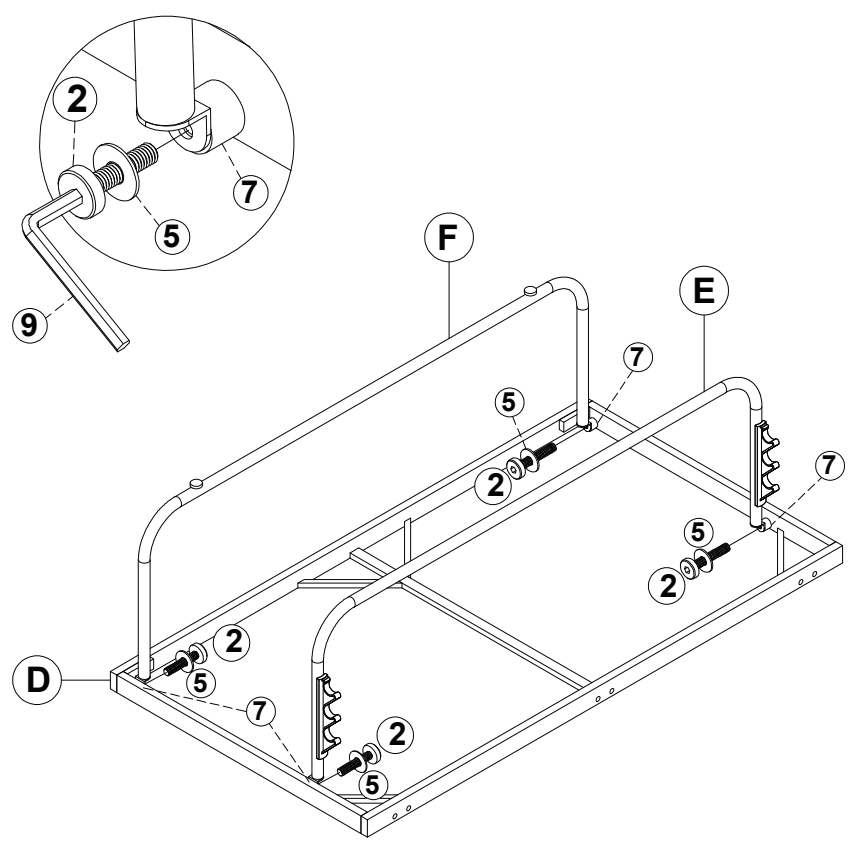

2

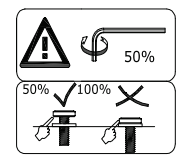
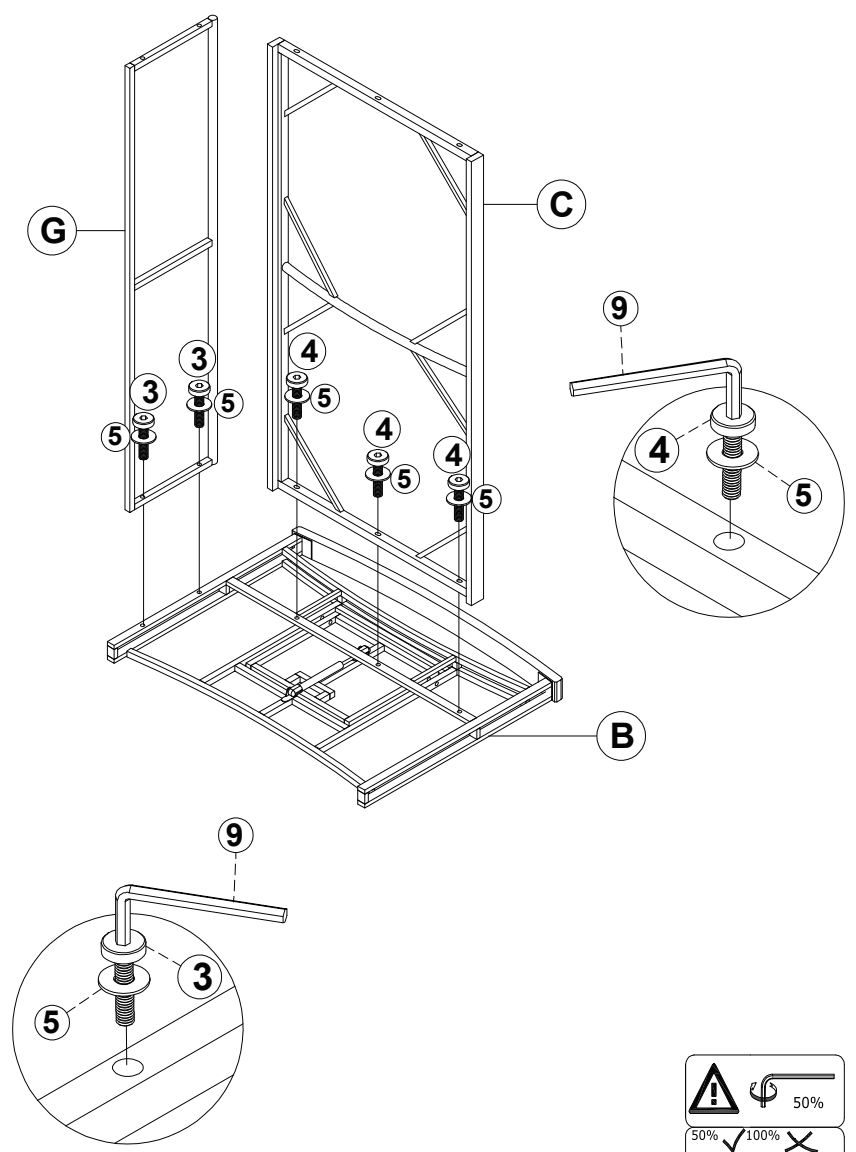

3

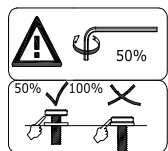
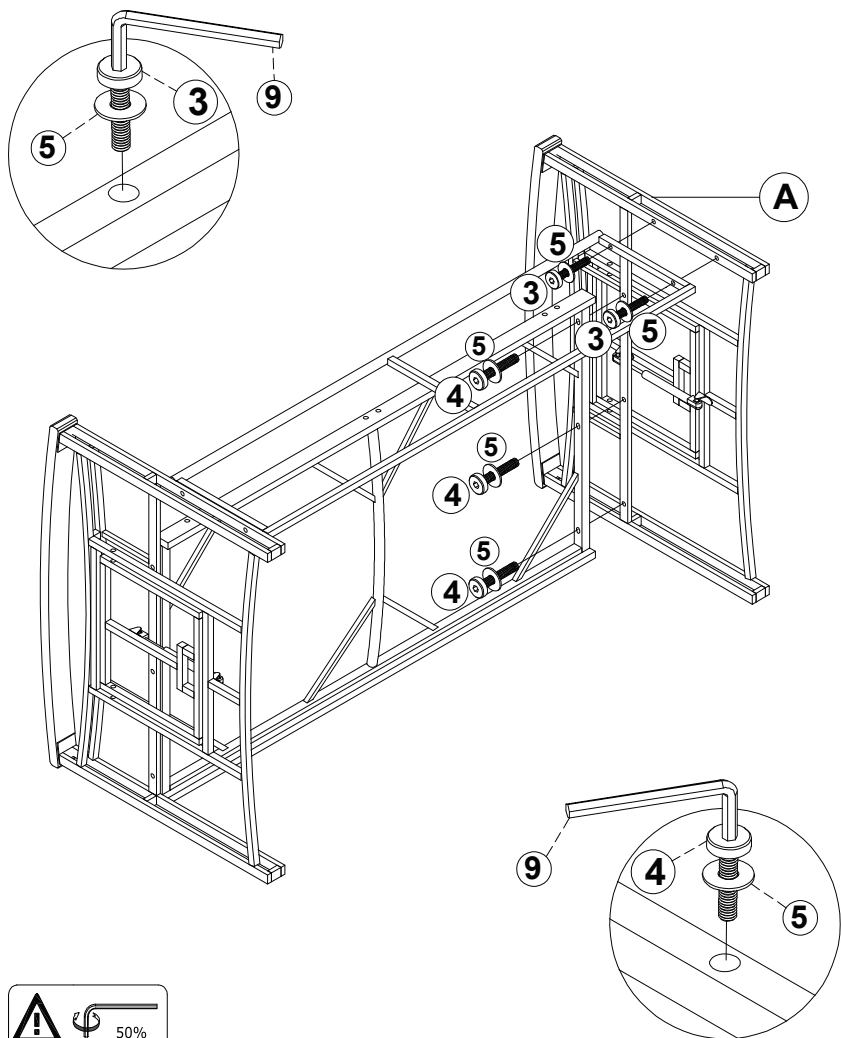

4

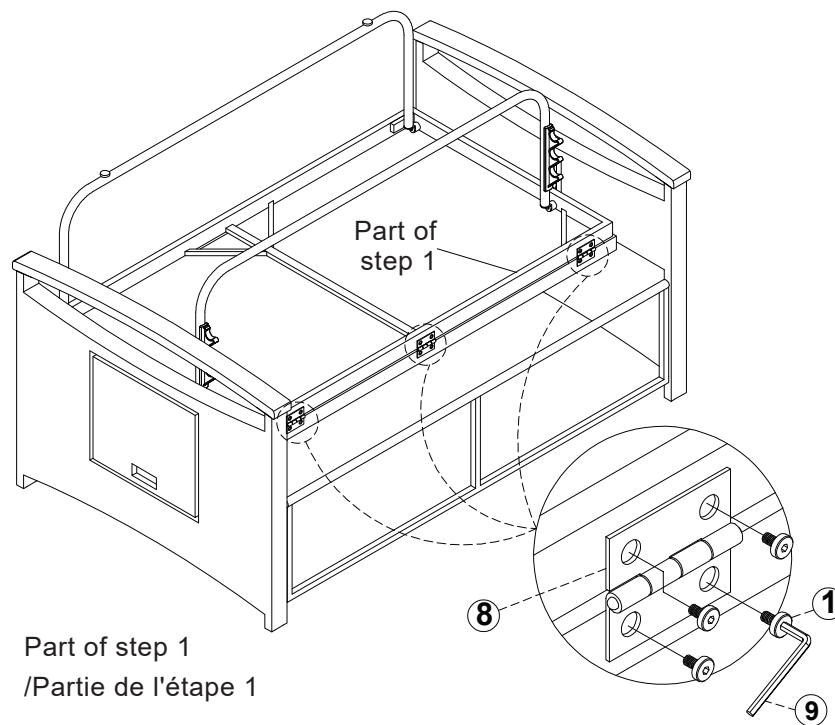

Part of step 1
/Partie de l'étape 1

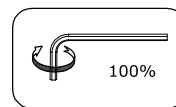

5

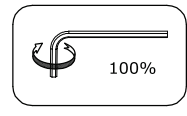
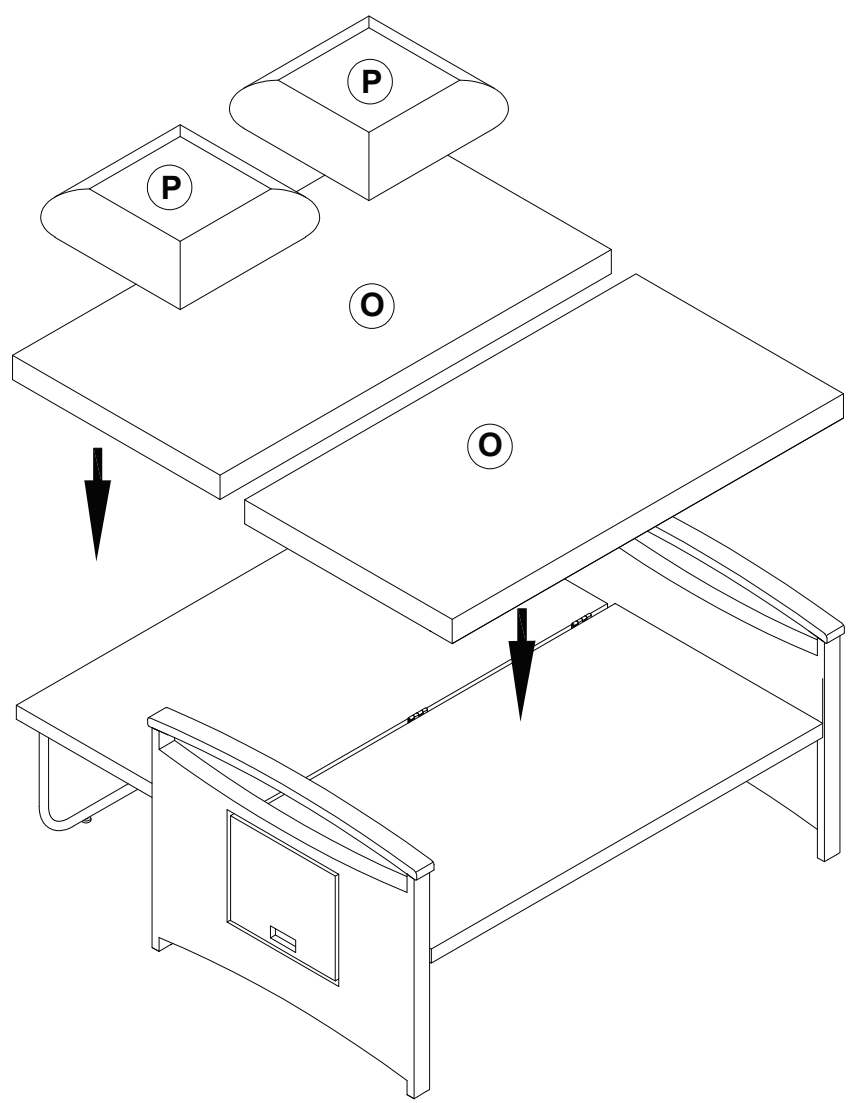

6

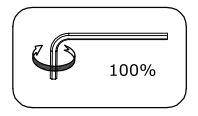
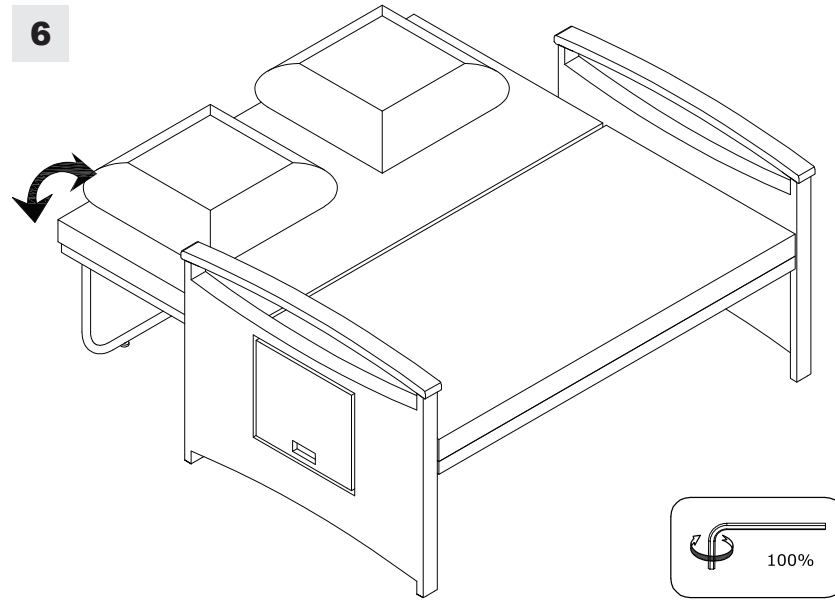

7

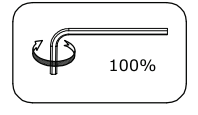
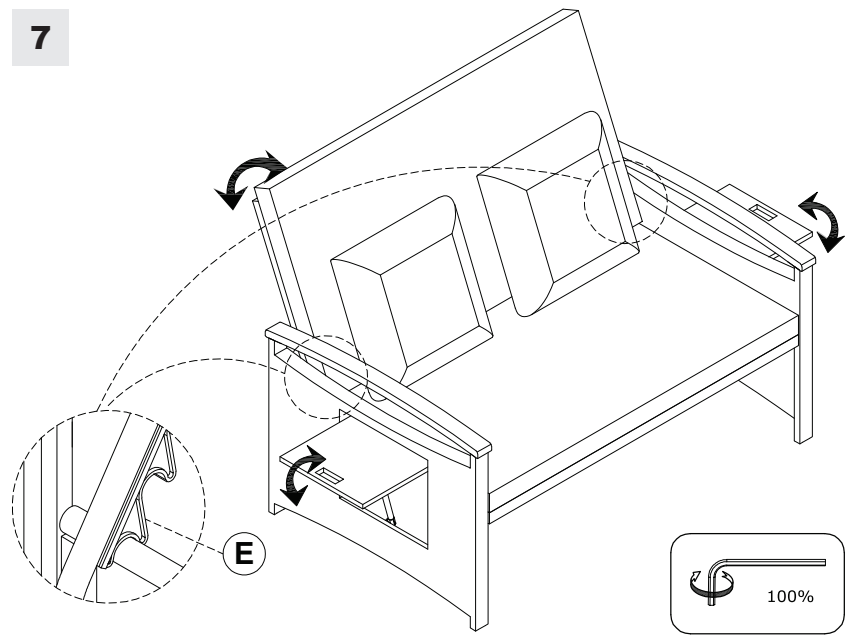

8

(1 x Stool assembly /Assemblage de 1 x tabouret)

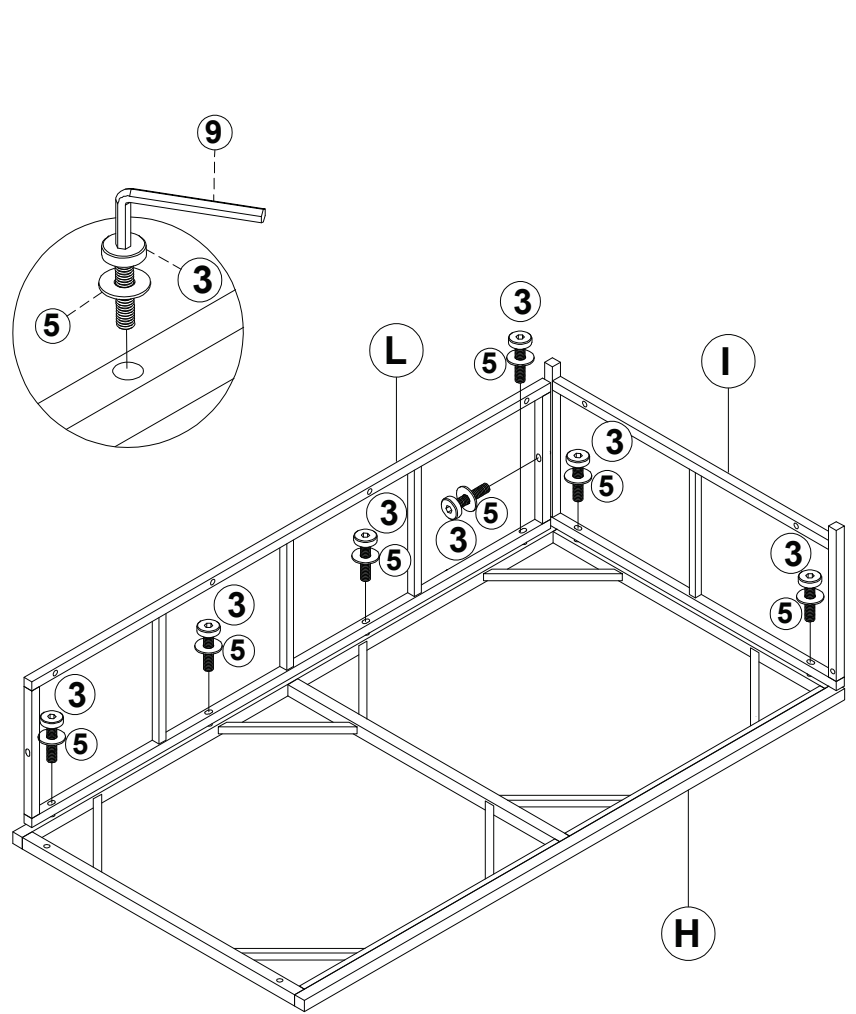

9

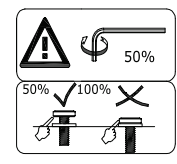
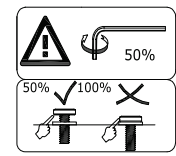
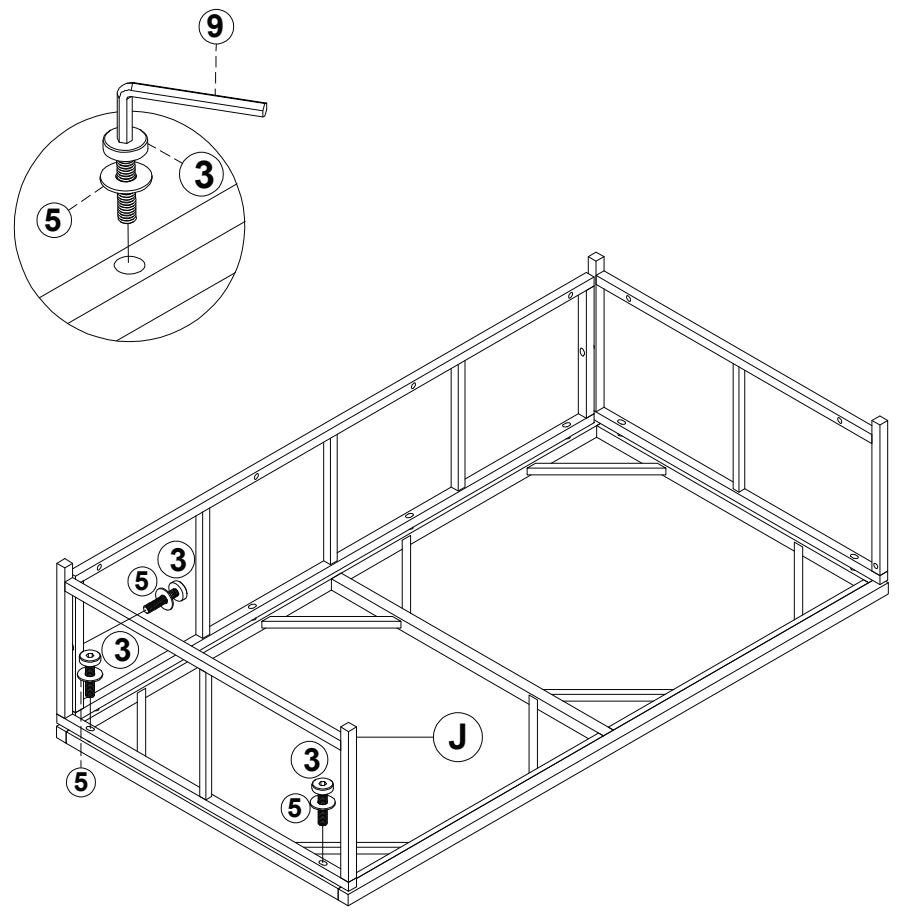

10

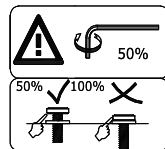
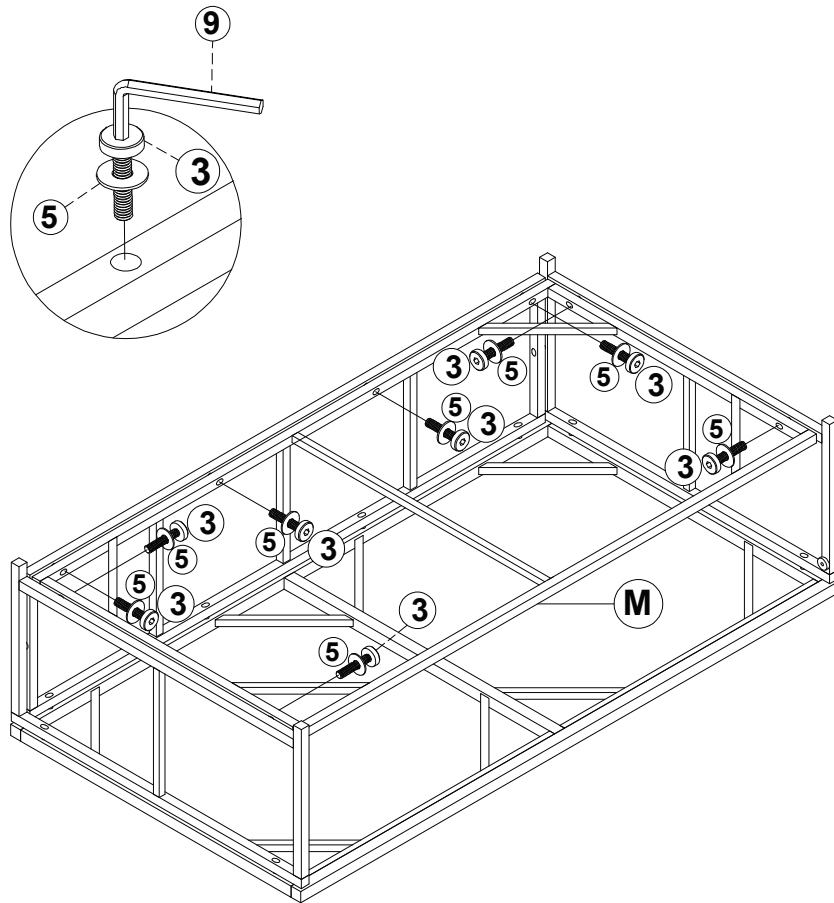

11

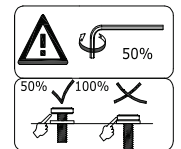
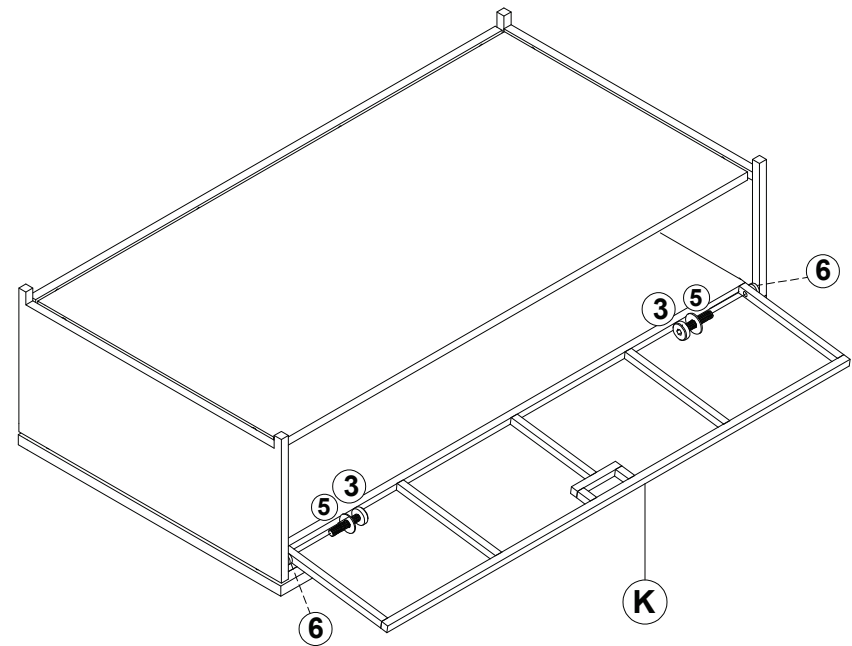

12

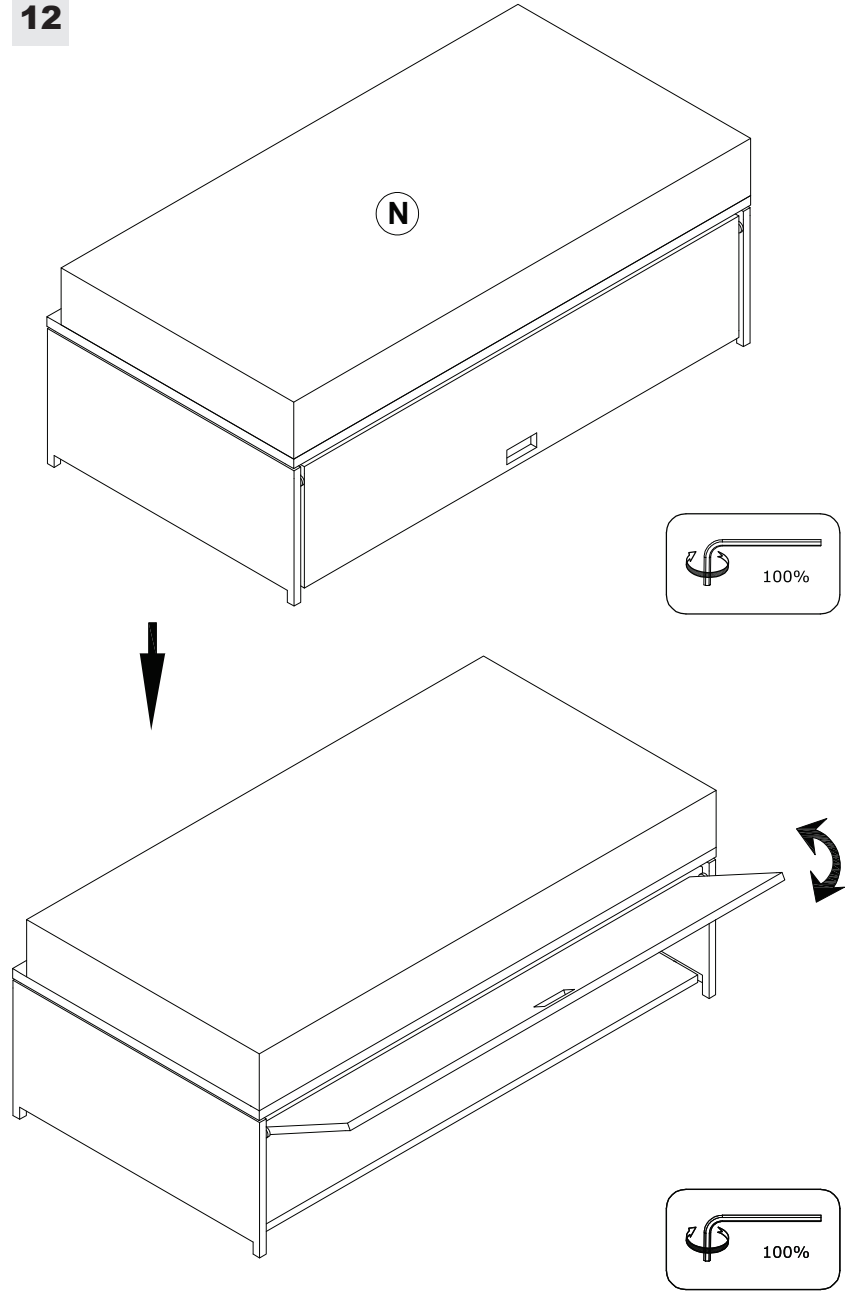

13

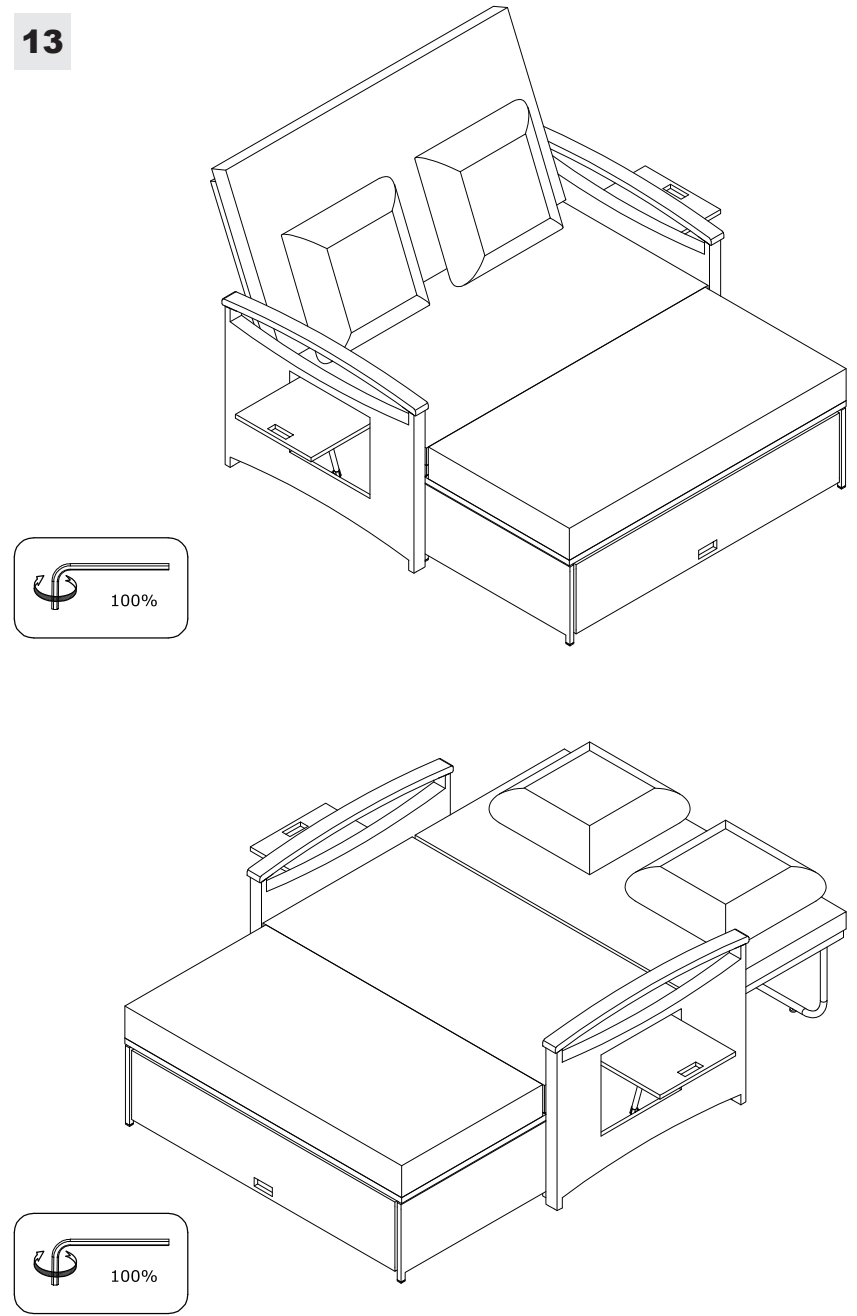

14

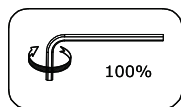
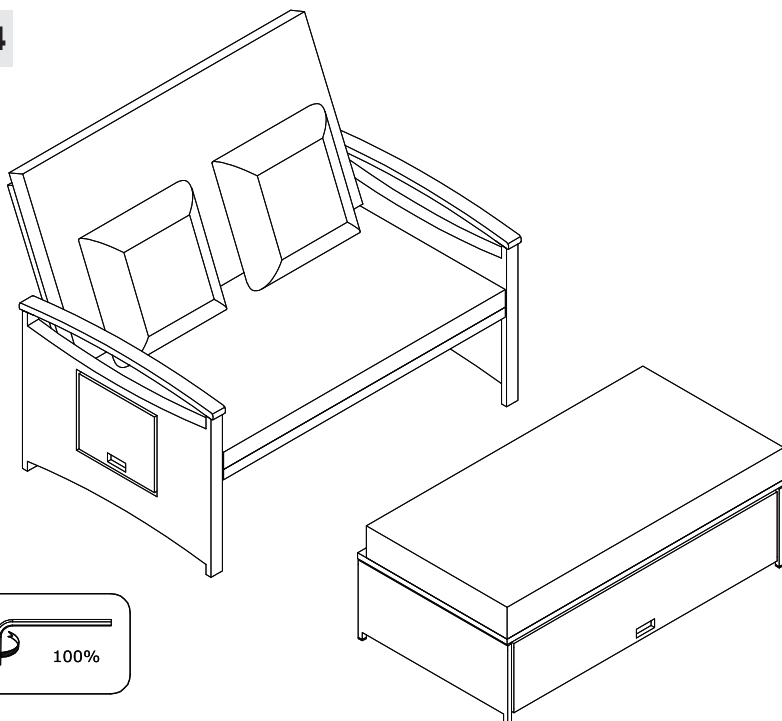

FINISH
/TERMINÉ

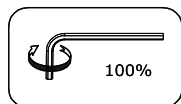
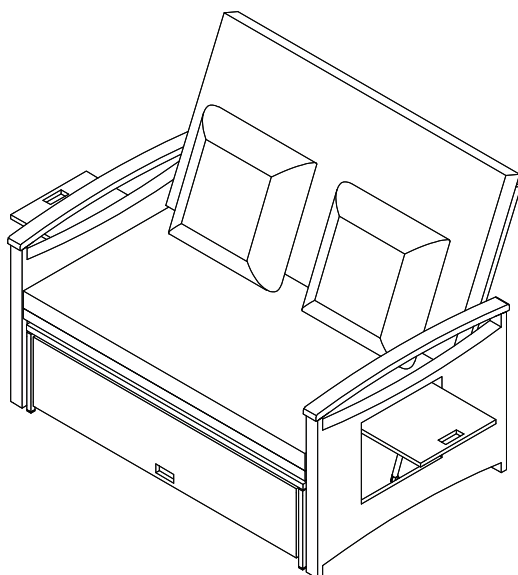

EN



Return / Damage Claim Instructions

- ⚠ **DO NOT discard the box / original packaging.**
In case a return is required, the item must be returned in original box. Without this your return will not be accepted.
- ⚠ **Take a photo of the box markings.**
A photo of the markings (text) on the side of the box is required in case a part is needed for replacement. This helps our staff identify your product number to ensure you receive the correct parts.
- ⚠ **Take a photo of the damaged part (if applicable).**
A photo of the damage is always required to file a claim and get your replacement or refund processed quickly. Please make sure you have the box even if it is damaged.
- ⚠ **Send us an email with the images requested.**
Email us directly from marketplace where your item was purchased with the attached images and a description of your claim.

FR



Instructions De Retour / Réclamation De Dommages

- ⚠ **NE PAS jeter la boîte/l'emballage d'origine.**
Dans le cas où un retour est requis, l'article doit être retourné dans sa boîte d'origine. Sans cela, votre retour ne sera pas accepté.
- ⚠ **Prenez une photo des marquages de la boîte.**
Une photo des marquages (texte) sur le côté de la boîte est requise au cas où une pièce serait nécessaire pour le remplacement. Cela aide notre personnel à identifier votre numéro de produit pour s'assurer que vous recevez les bonnes pièces.
- ⚠ **Prenez une photo des dommages (le cas échéant).**
Une photo des dommages est toujours requise pour déposer une réclamation et obtenir rapidement votre remplacement ou votre remboursement. Assurez-vous d'avoir la boîte même si elle est endommagée.
- ⚠ **Envoyez-nous un e-mail avec les images demandées.**
Envoyez-nous un e-mail directement depuis le marché où votre article a été acheté avec les images ci-jointes et une description de votre réclamation.