

Kitchen Island Cart  
**KC58362**

THIS INSTRUCTION BOOKLET CONTAINS **IMPORTANT** SAFETY INFORMATION.  
PLEASE READ AND KEEP FOR FUTURE REFERENCE.



## Before You Start

- ⚠ Please read all instructions carefully.
- ⚠ Retain instructions for future reference.
- ⚠ Separate and count all parts and hardware.
- ⚠ Read through each step carefully and follow the proper order.
- ⚠ We recommend that, where possible, all items are assembled near to the area in which they will be placed in use, to avoid moving the product unnecessarily once assembled.
- ⚠ Always place the product on a flat, steady and stable surface.
- ⚠ Keep all small parts and packaging materials for this product away from babies and children as they potentially pose a serious choking hazard.

# Parts List

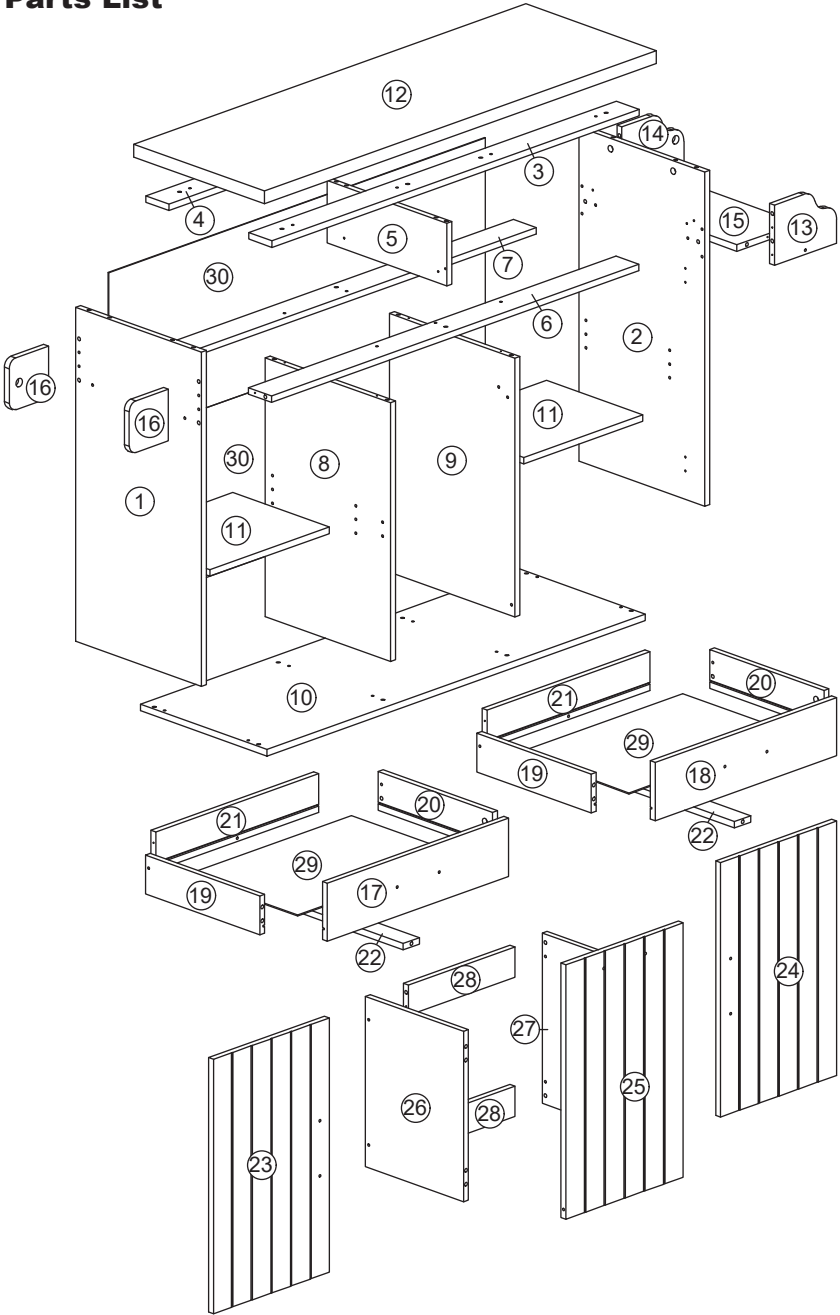

# Hardware List

	
8x25mm	
(A)	x52

Wood Dowel

	
8x20mm	
(B)	x8

Wood Dowel

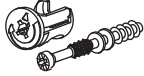
	
15MM	
(C)	x16

Bolt & Cap

	
M3.5x16mm	
(D)	x64

Screw

	
M4x45mm	
(E)	x38

Screw

	
M3.5x12mm	
(F)	x12

Screw

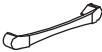
	
(G)	x5

Handle

	
M4x28mm	
(H)	x18

Screw

	
(I)	x8

Shelf Support

	
6x22mm	
(J)	x2

Shelf Support

	
7/8"	
(K)	x4

Hinge

	
(L)	x2

Caster (with Brake)

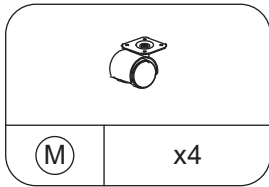

Caster (without Brake)

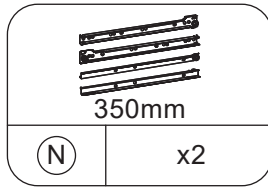

Drawer Slide

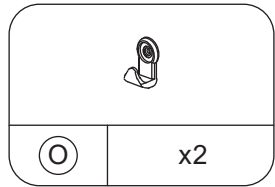

Hook

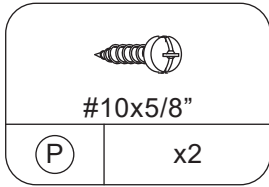

Tapping Screw

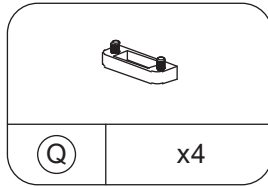

2-Pin Stopper

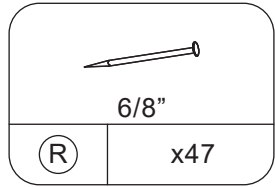

Power Pin

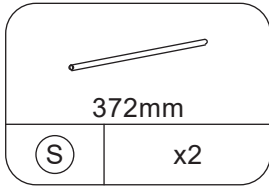

Aluminium Pipe

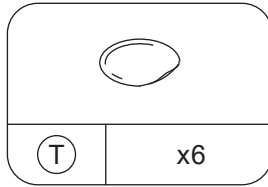

Sticker

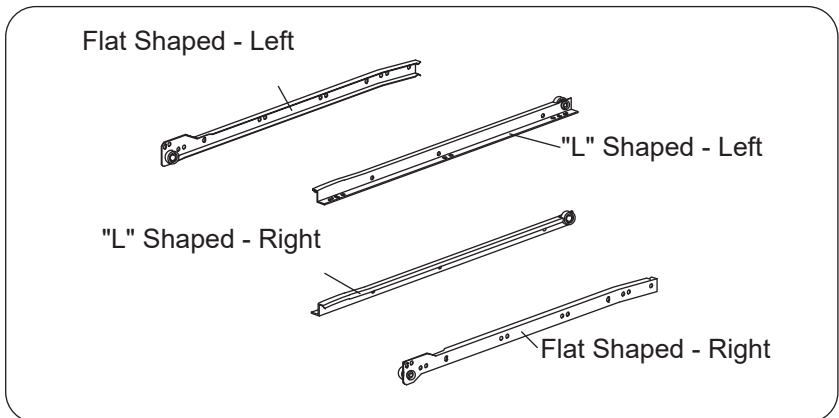

1

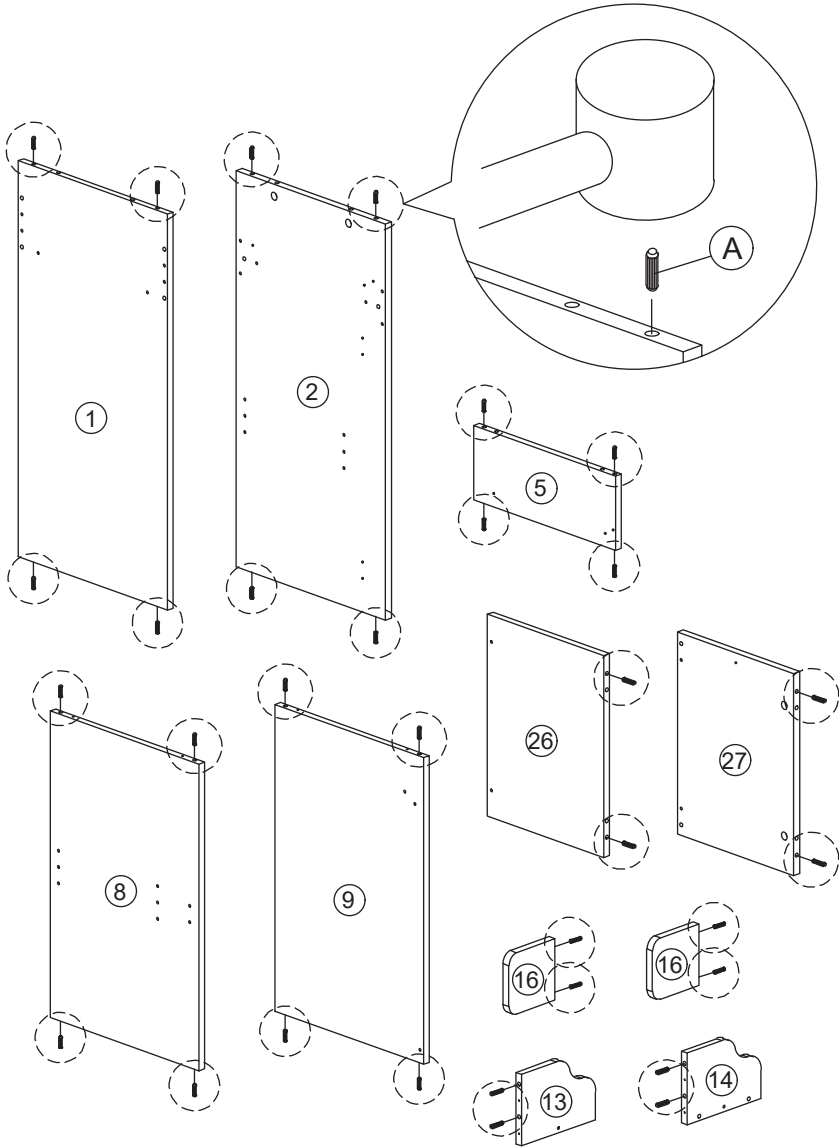
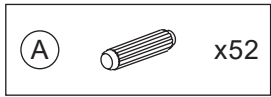

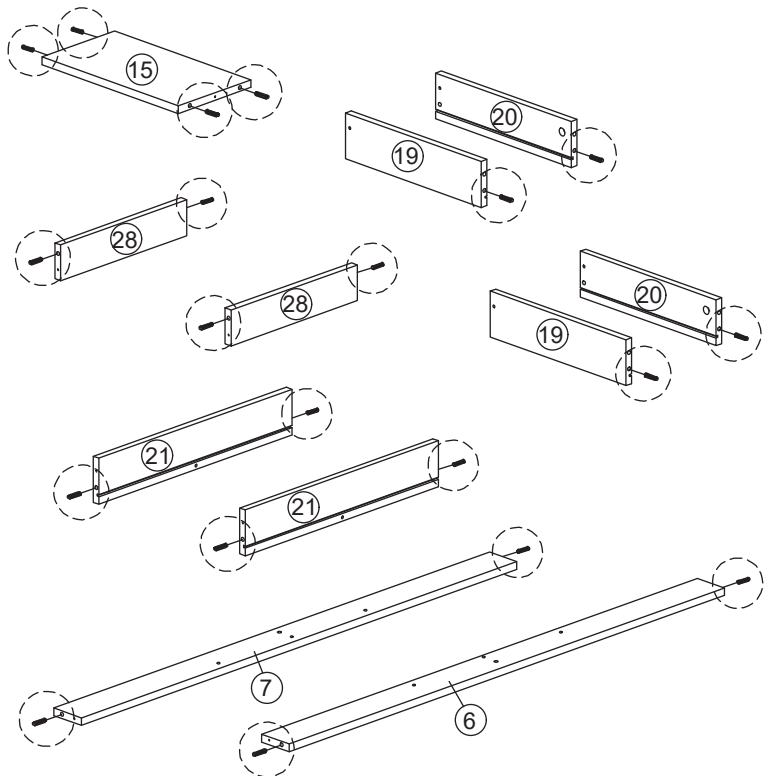

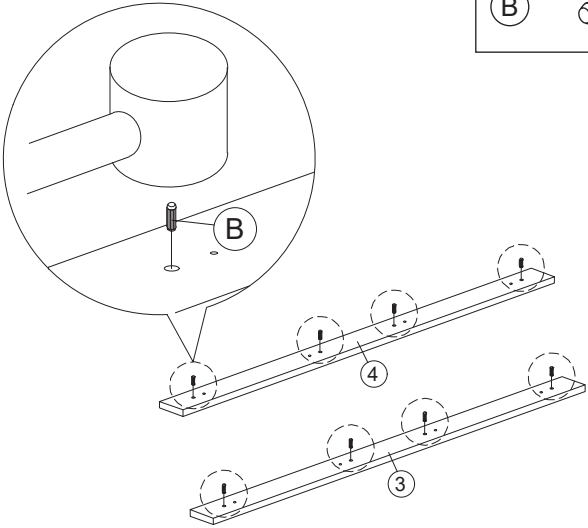

**2**

<b>B</b>		x8
----------	---	----



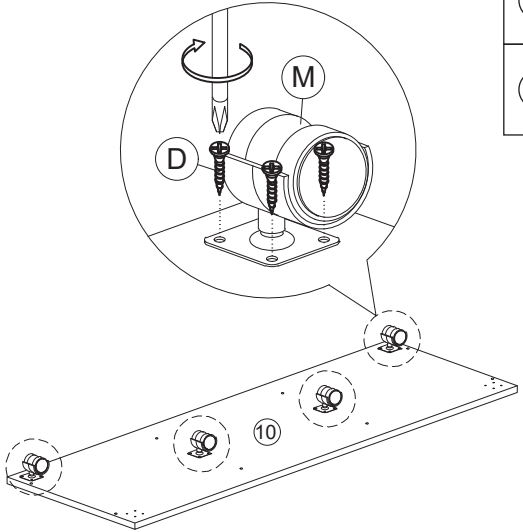

**3**

<b>D</b>		x16
<b>M</b>		x4



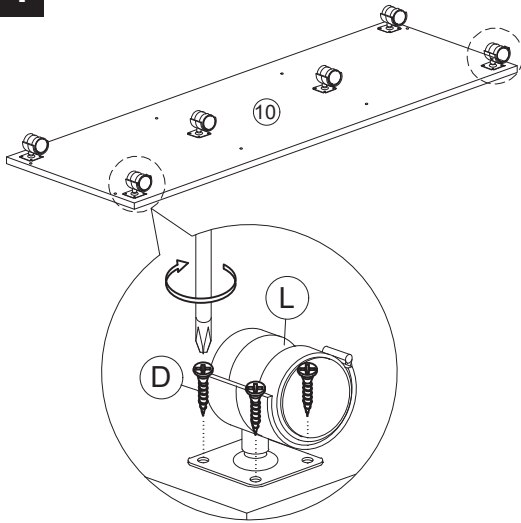

4

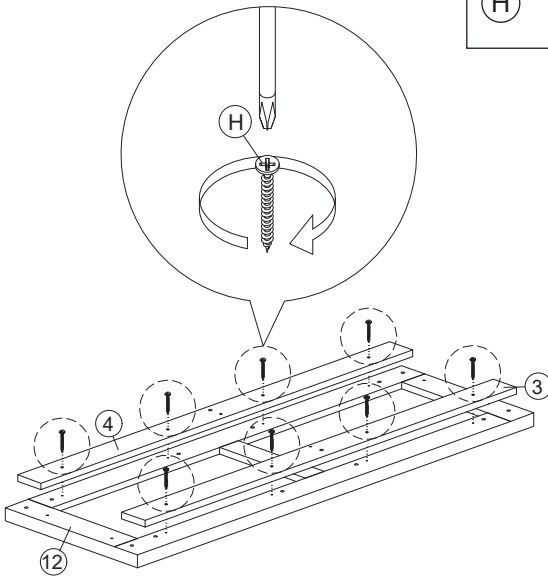

(D)		x8
(L)		x2

5



(H)		x8
-----	---	----

6



(C)

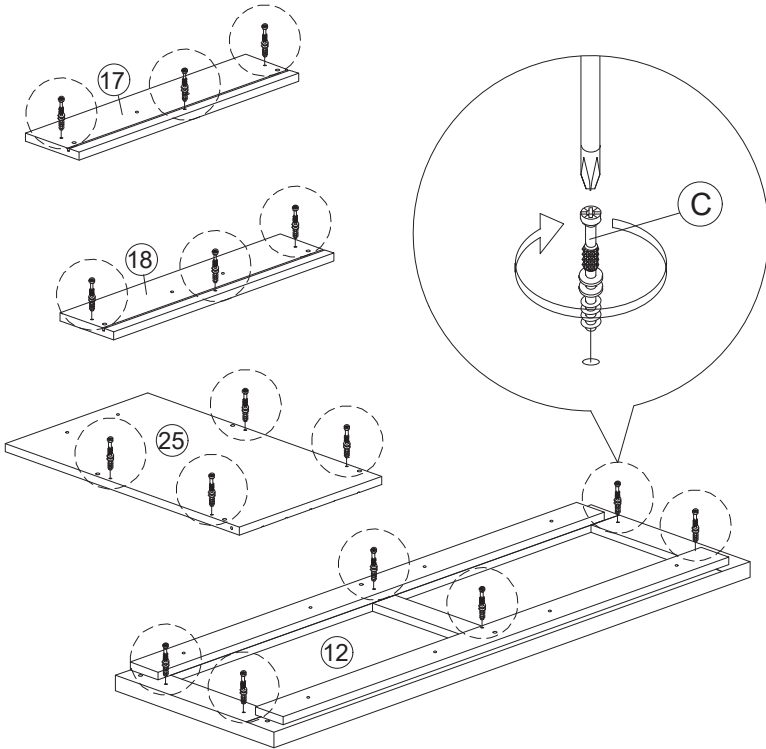

x16



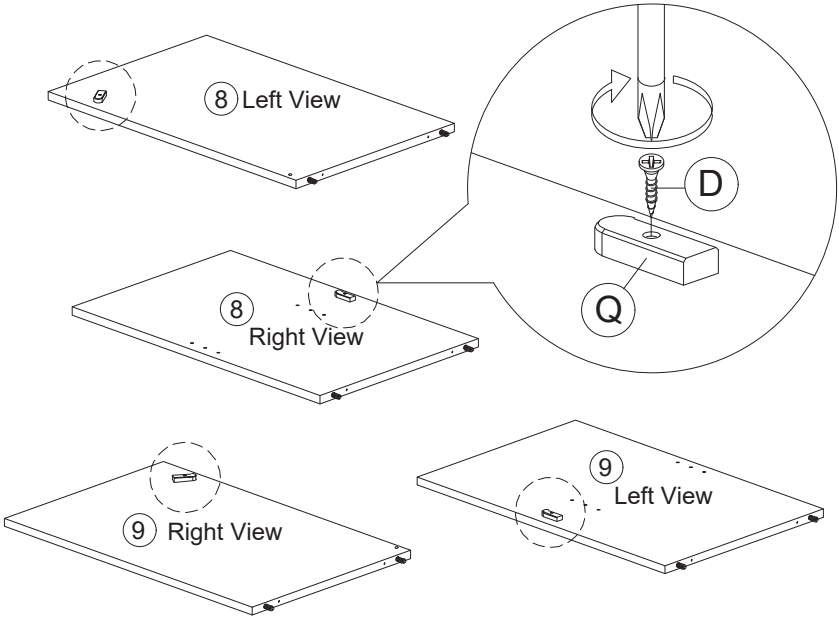

7

D		x4	Q		x4
---	---	----	---	---	----



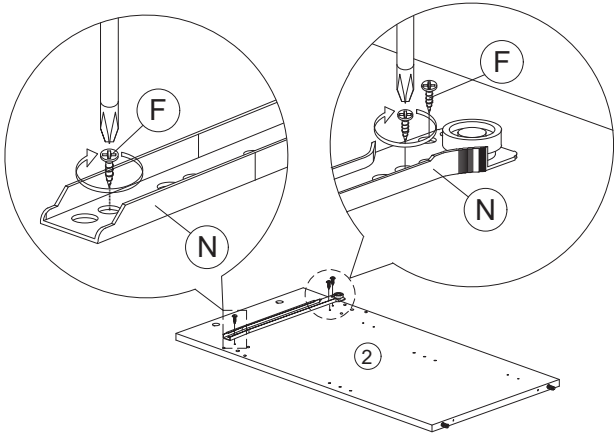
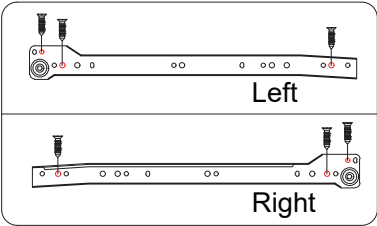
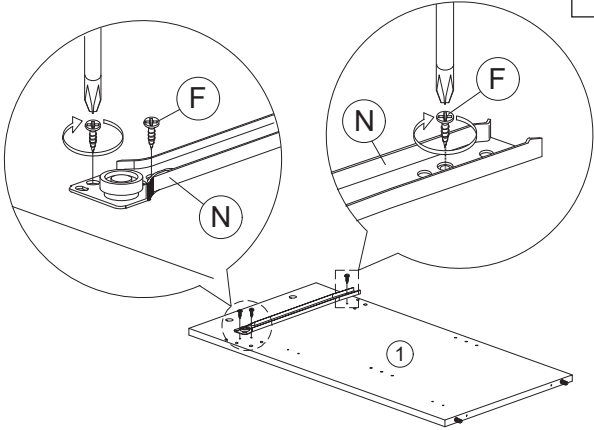

**8**

(F)  x6	(N)  x1
	(N)  x1



9

(F)  x6	(N)  x1
	(N)  x1

Left View

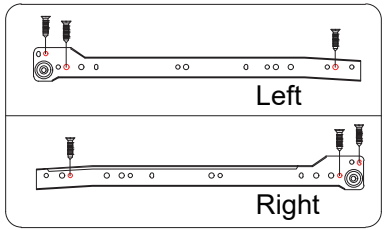
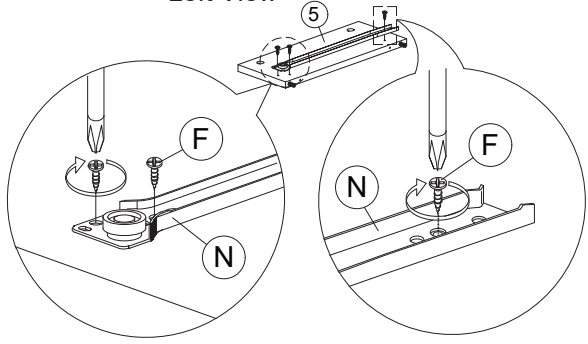

Right View

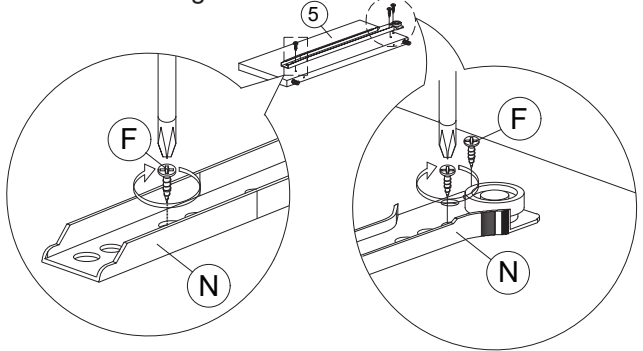

**10**

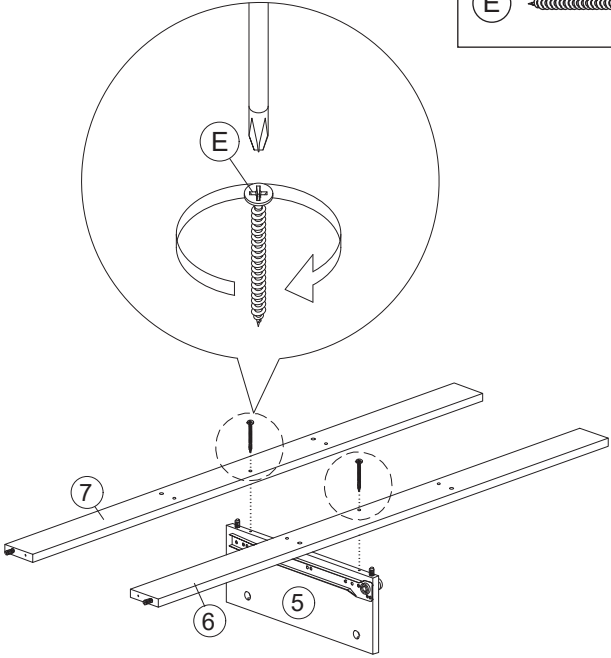
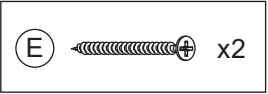

**11**

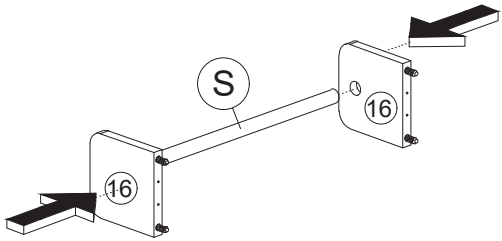
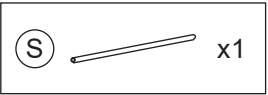

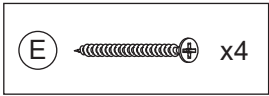
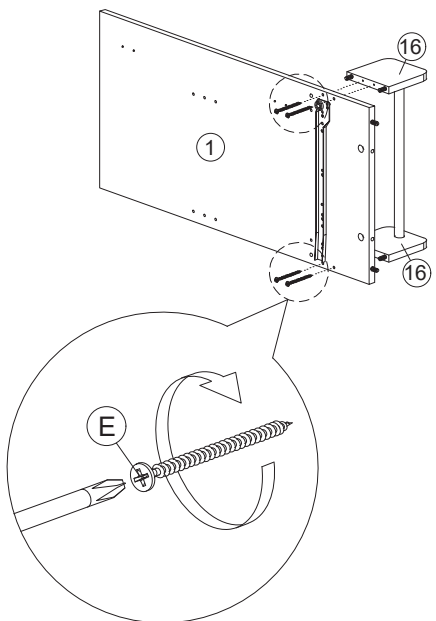

**12**

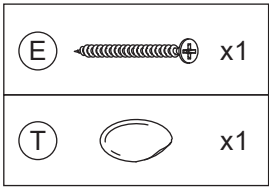
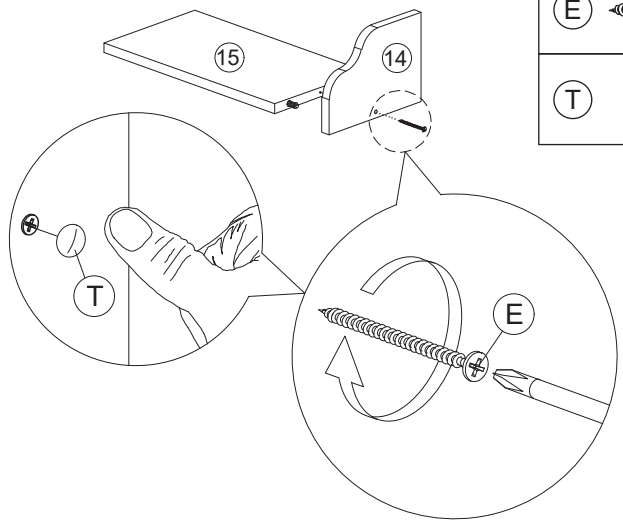

**13**



<p>(E)  x1</p>	<p>(T)  x1</p>
<p>(S)  x1</p>	

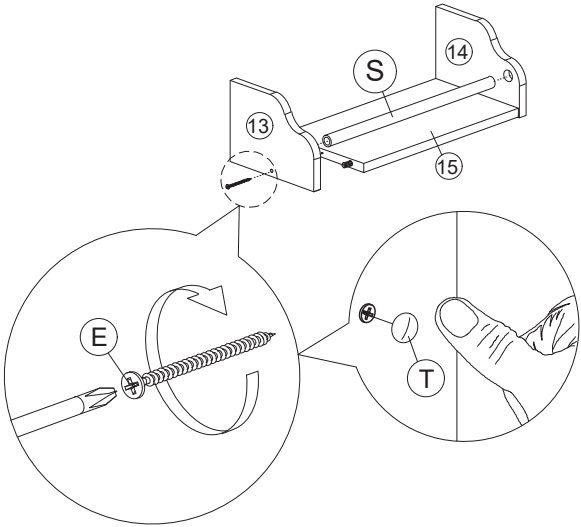

**15**

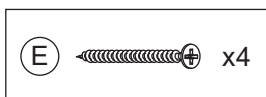
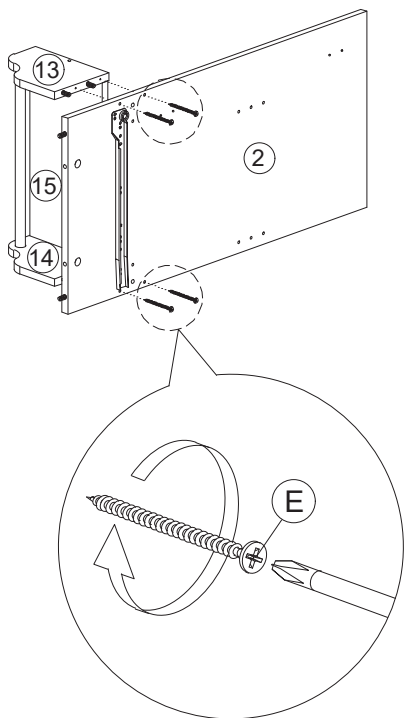

**16**

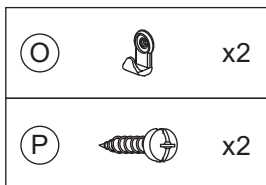
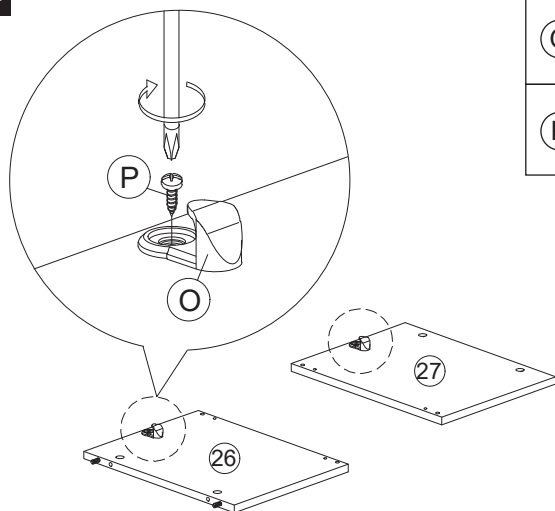

17

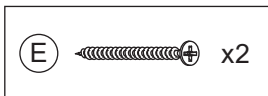
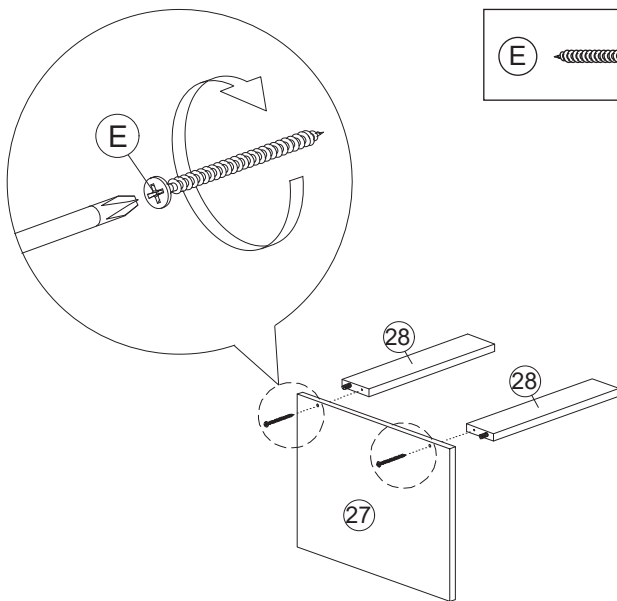

18

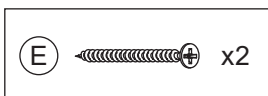
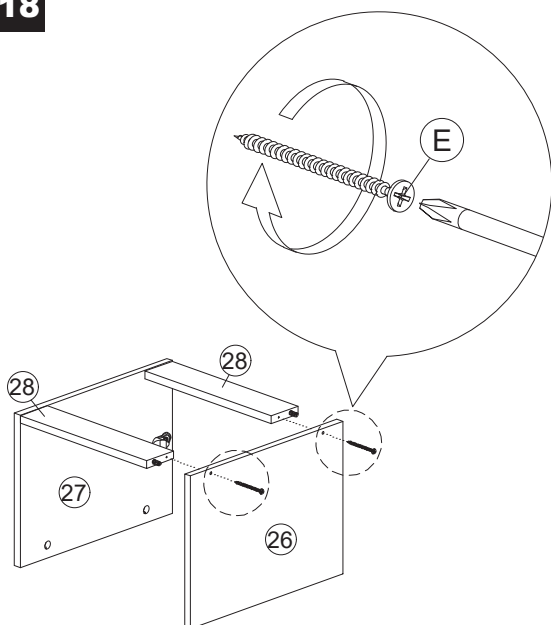

**19**

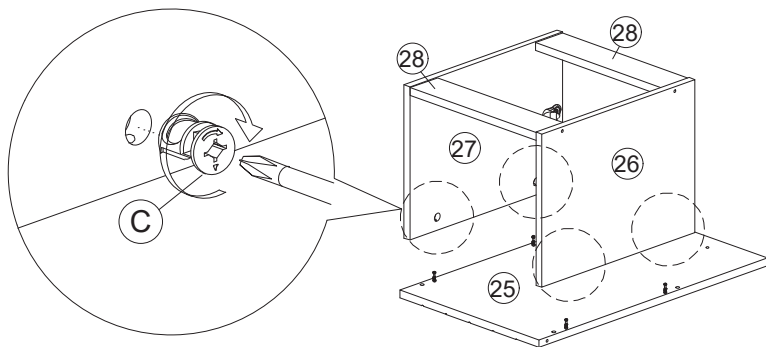
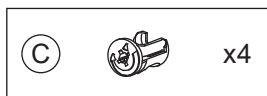

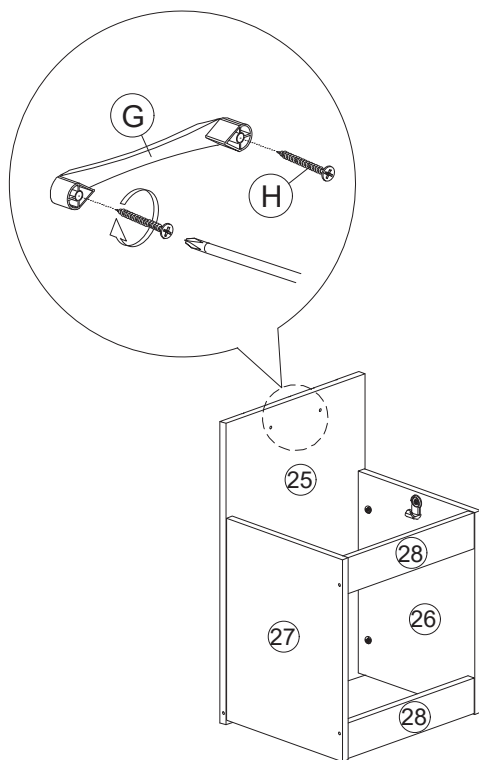
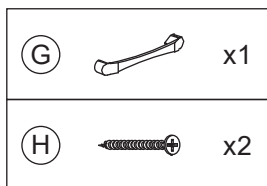

**20**

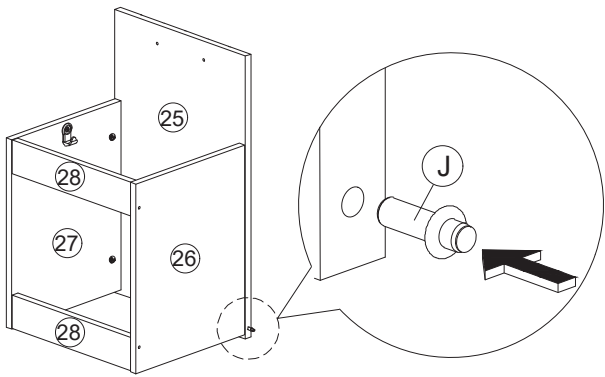
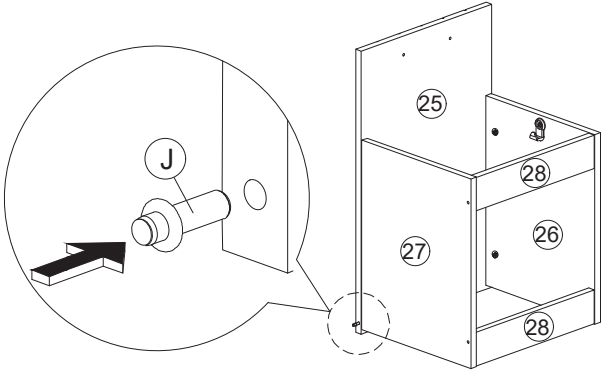
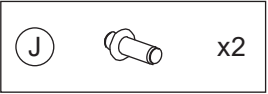

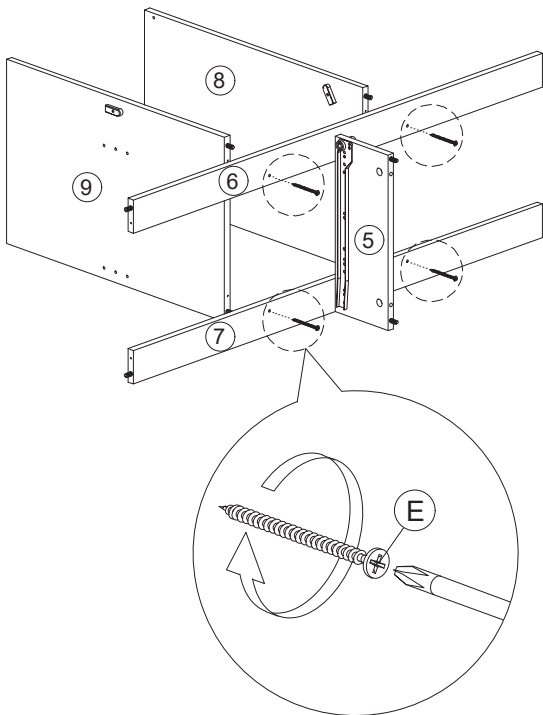
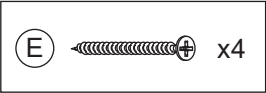



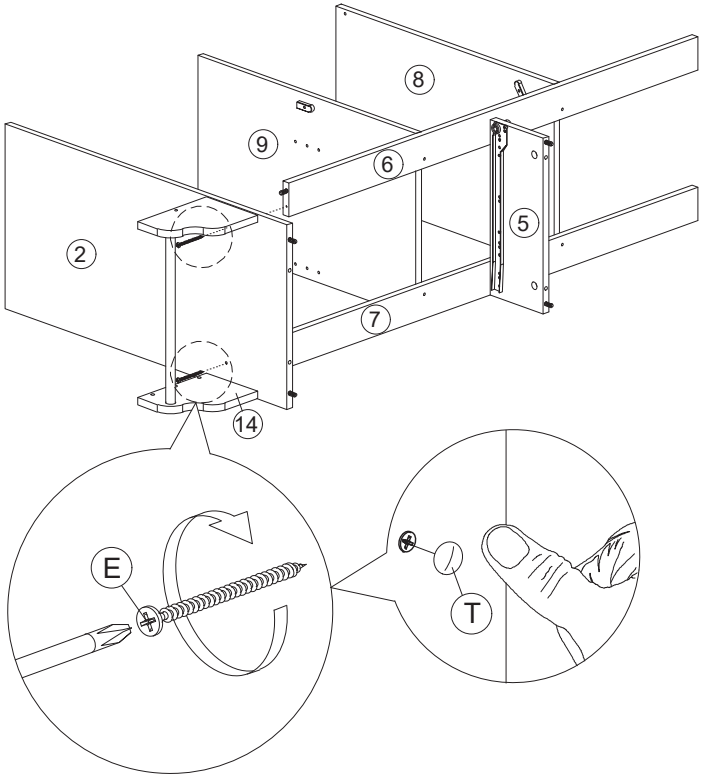

E		x2
T		x2



E		x2
T		x2

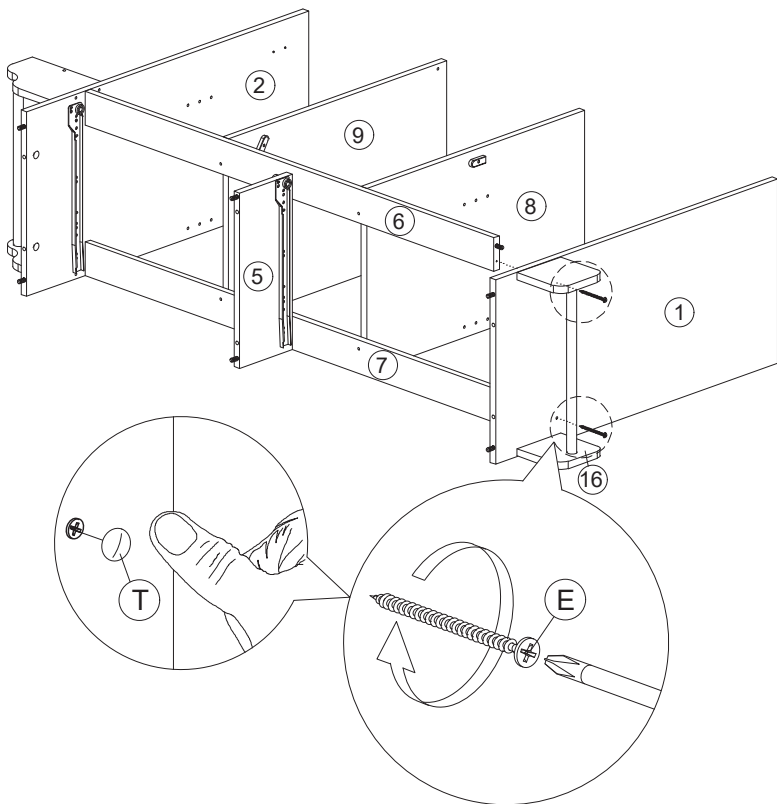

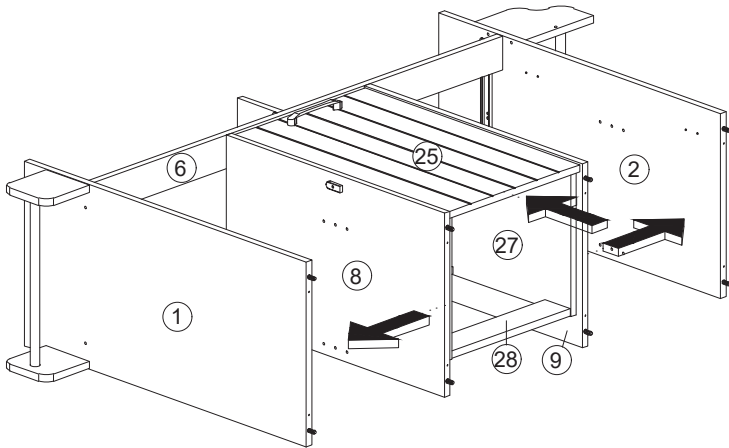

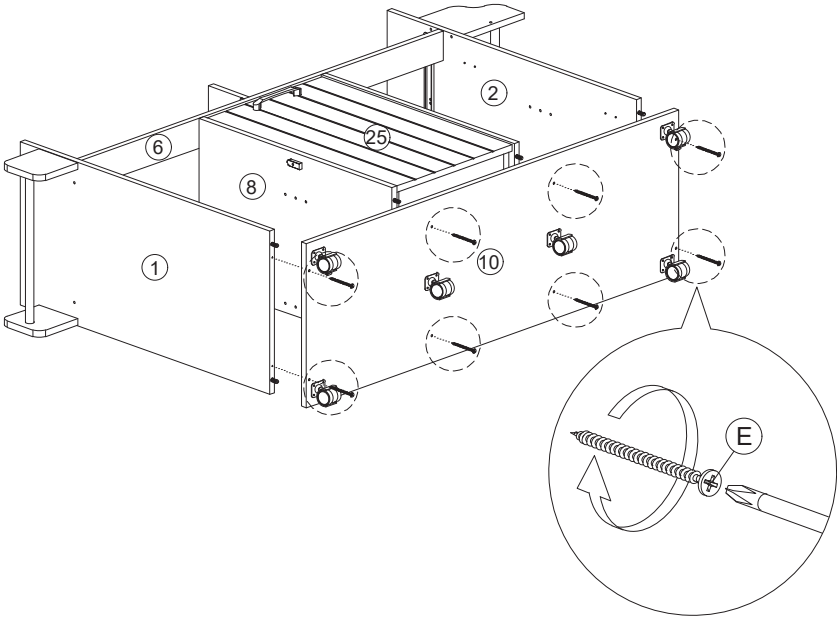
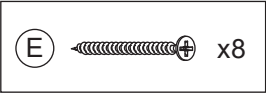

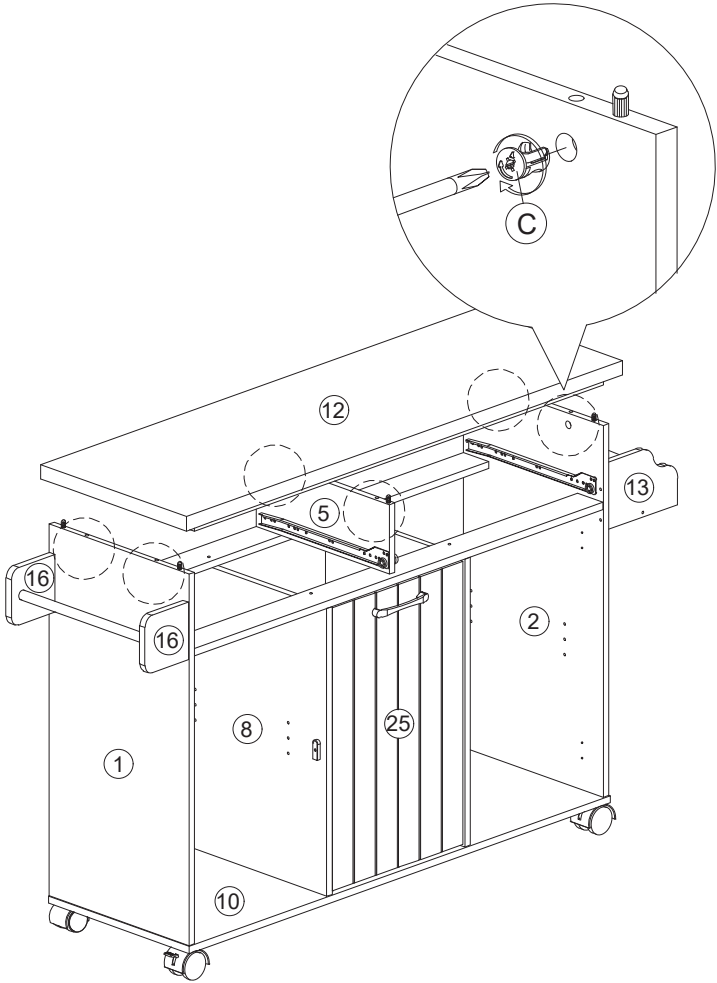
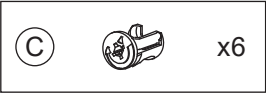

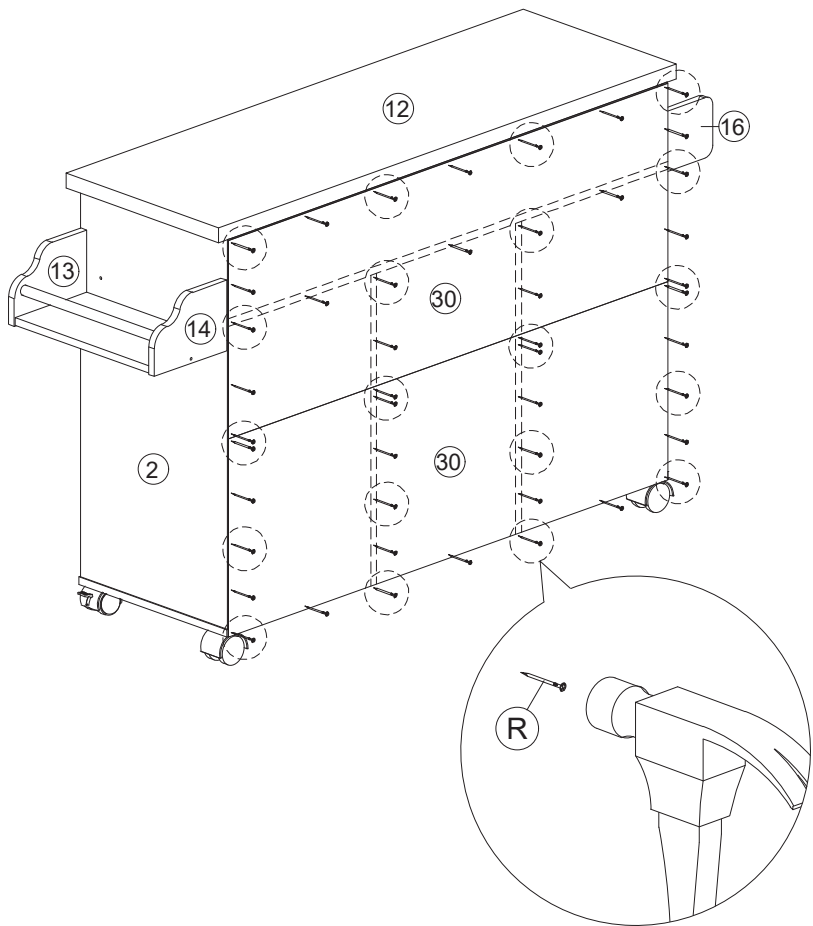
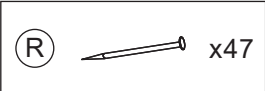

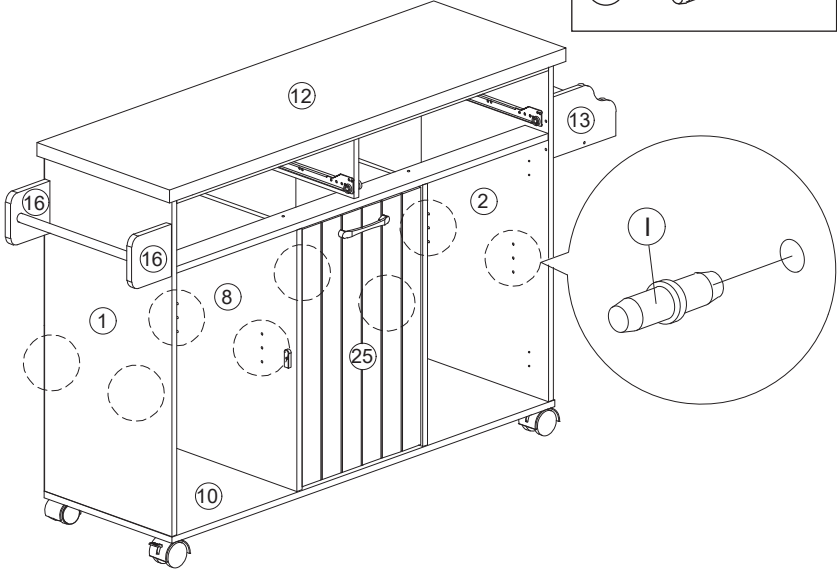
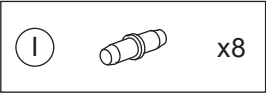

**29**

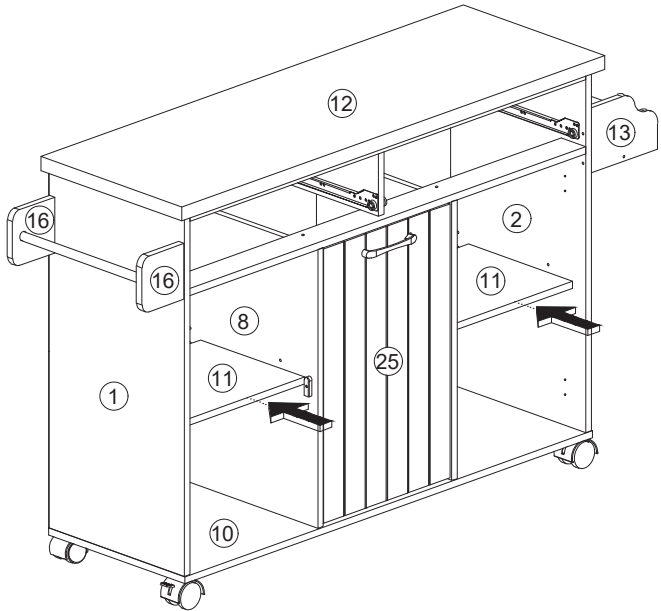

**30**



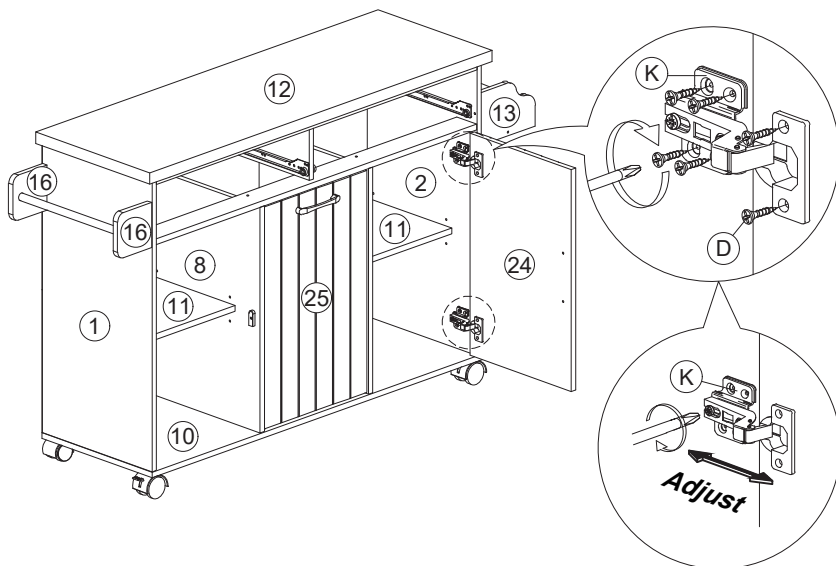

**31**

<b>D</b>		x12	<b>K</b>		x2
----------	---	-----	----------	---	----



**32**

<b>G</b>		x1
<b>H</b>		x2

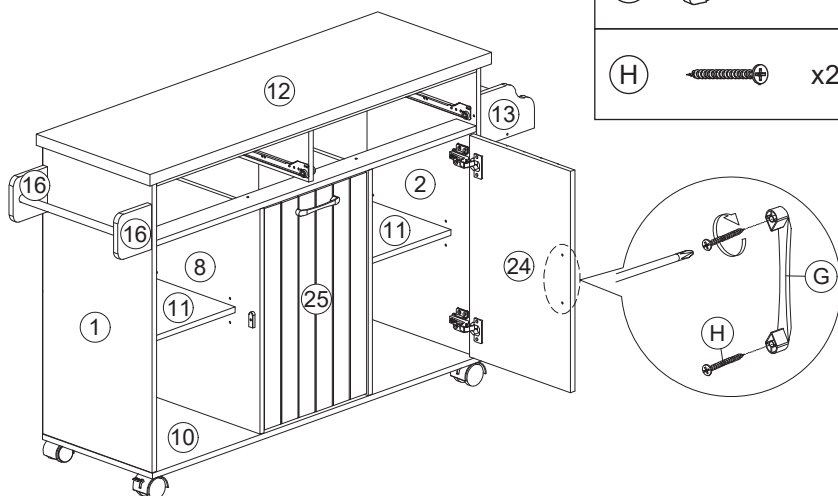

**33**

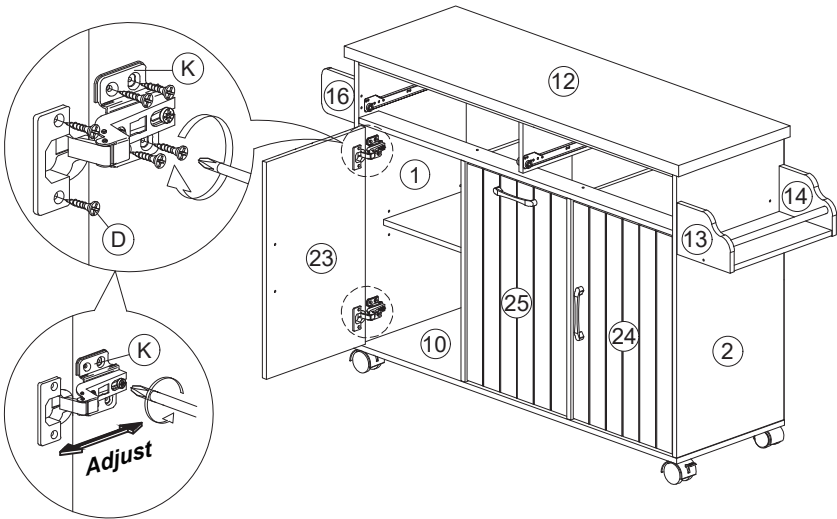
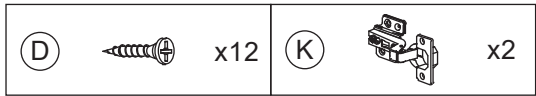

**34**

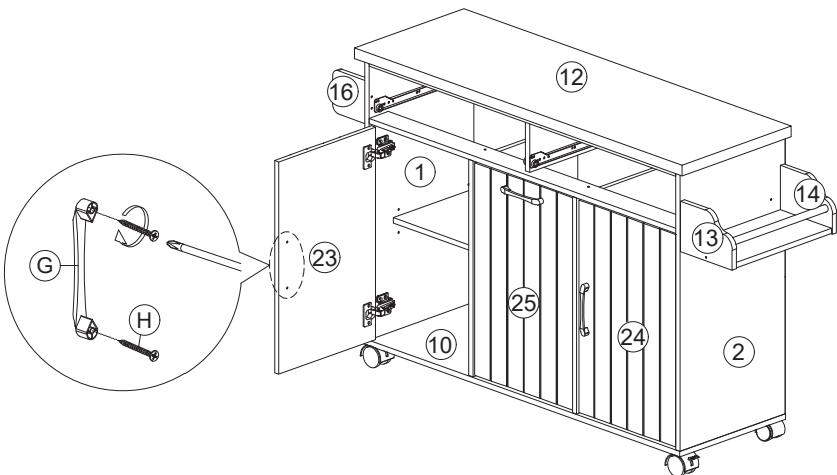
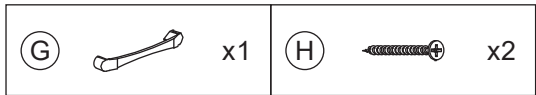

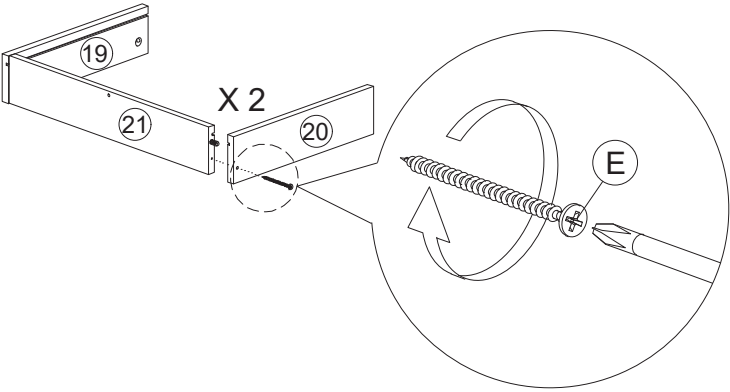
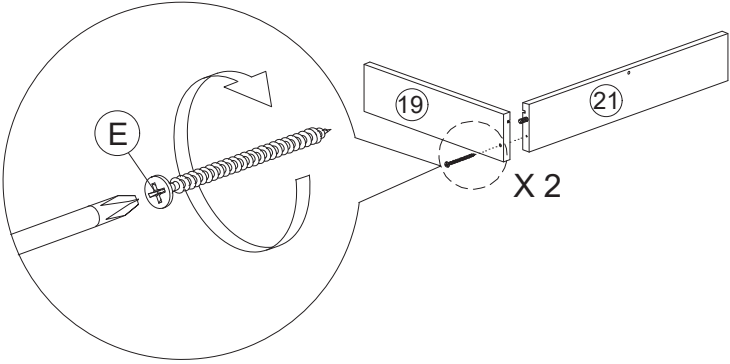
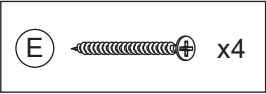

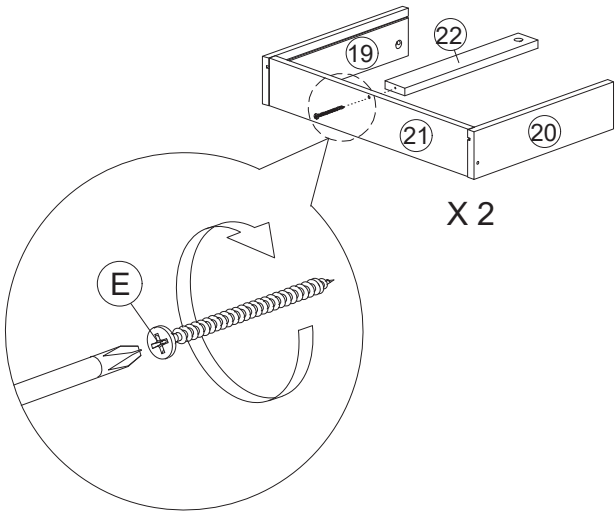
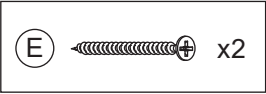

**36**



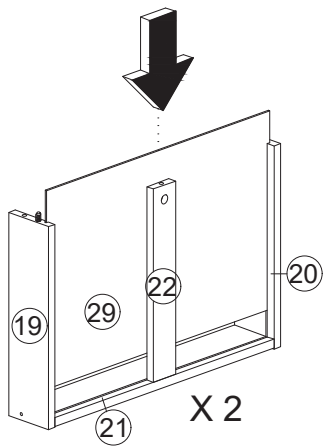

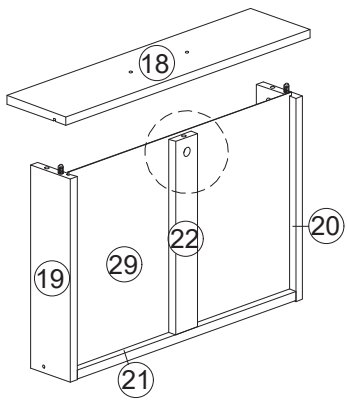
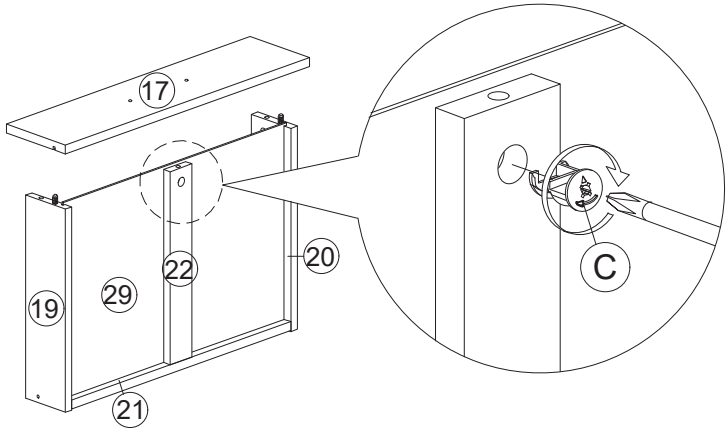
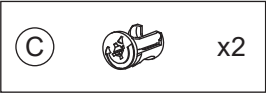
**37**



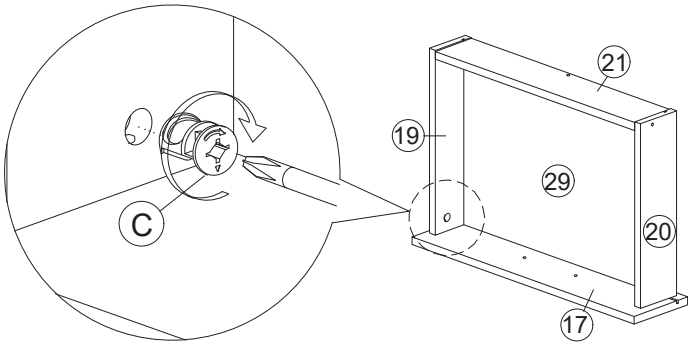
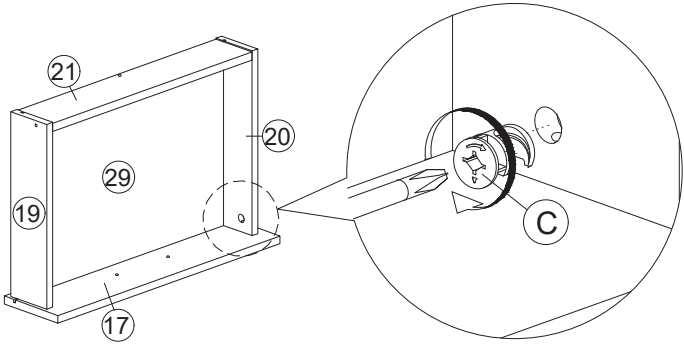

(C)  x2



(C)  x2

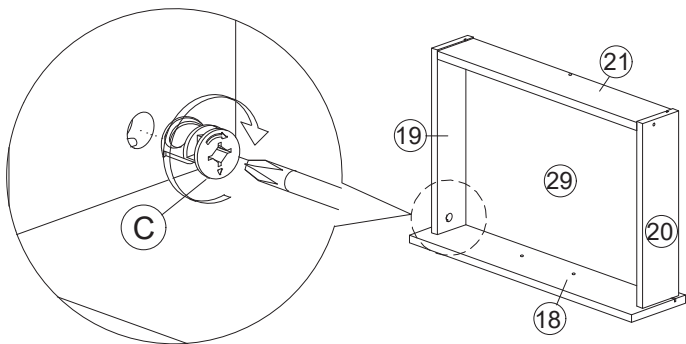
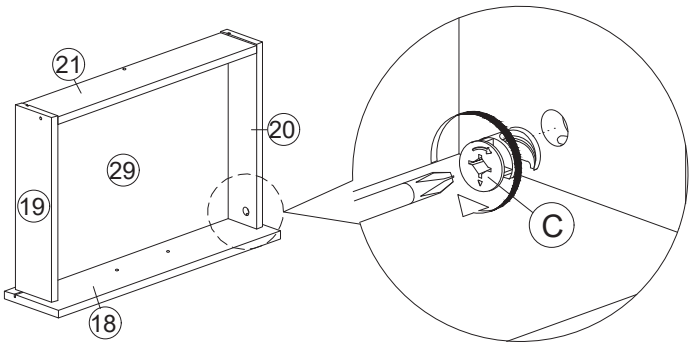

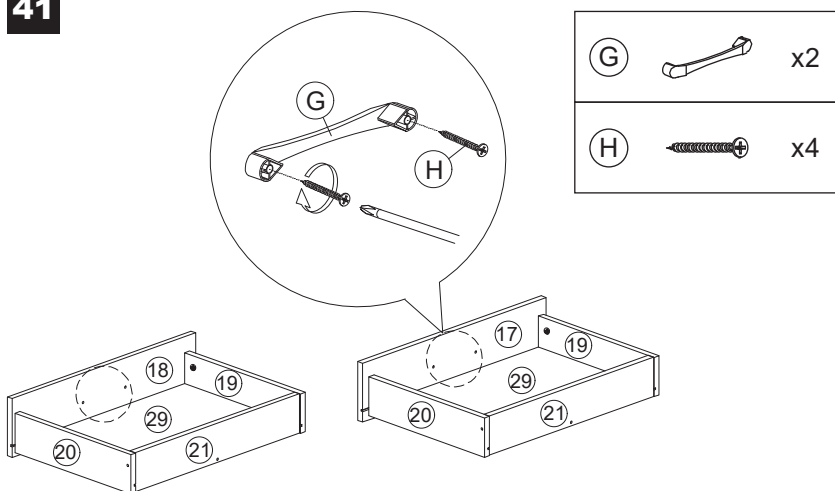

**41**

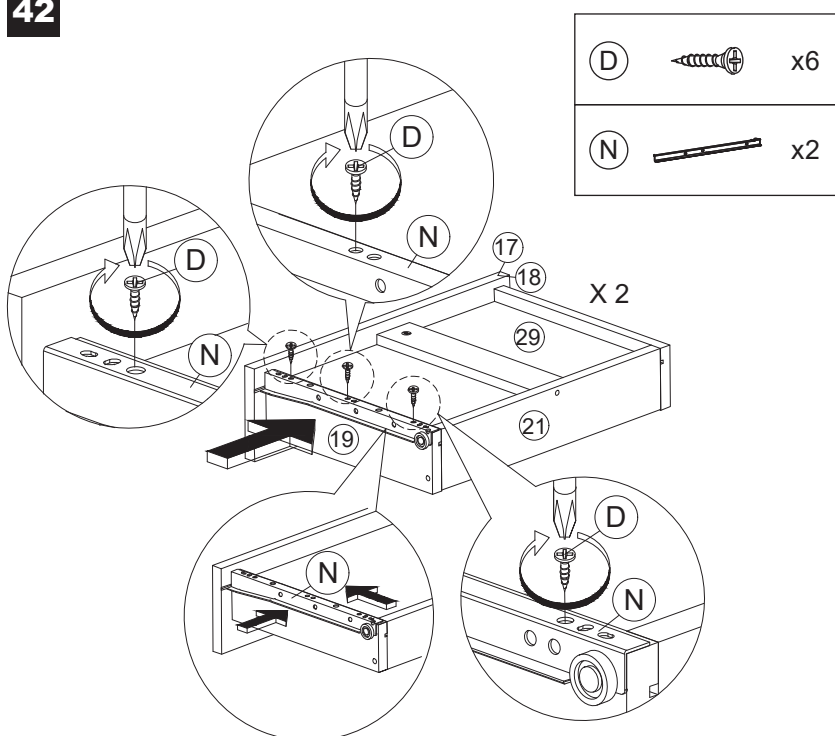

**42**



D		x6
N		x2

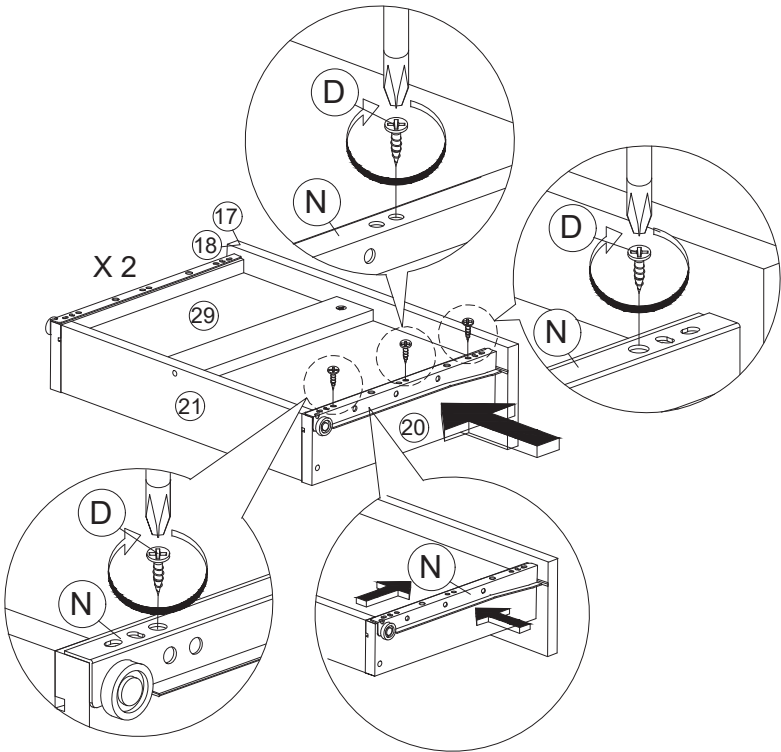

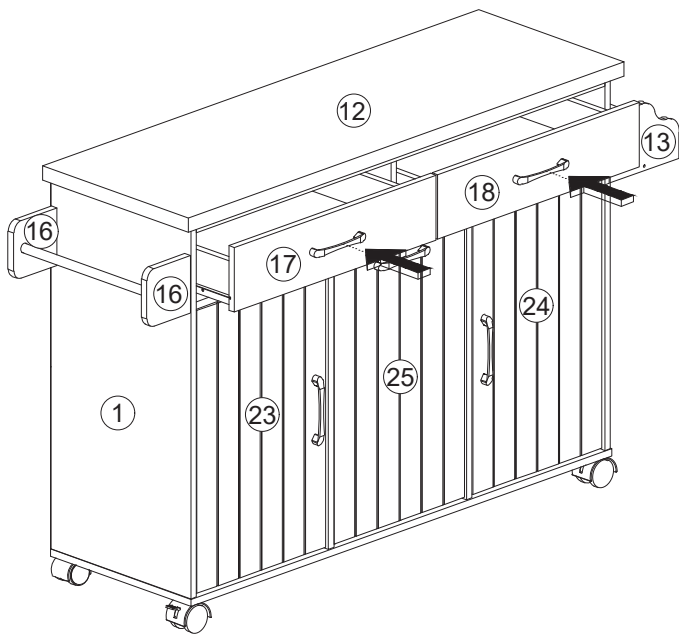



**USA** office: Fontana      **AUS** office: Truganina  
**GBR** office: FDS Corporation Limited, Unit 4, Blackacre  
Road, Great Blakenham, Ipswich, IP6 0FL, United Kingdom