

TRASMAN

DESIGNED & MADE IN
100%
BARCELONA

MANUAL DE MONTAJE
NOTICE DE MONTAGE - ASSEMBLY MANUAL
MONTAGEANLEITUNG - MANUAL DE
MONTAGEM - MONTAGE INSTRUCTIES
MONTÁŽNÍ NÁVOD
تعليمات التجميع:

9180 BUC

V.01 - 04/20



60 min



x2

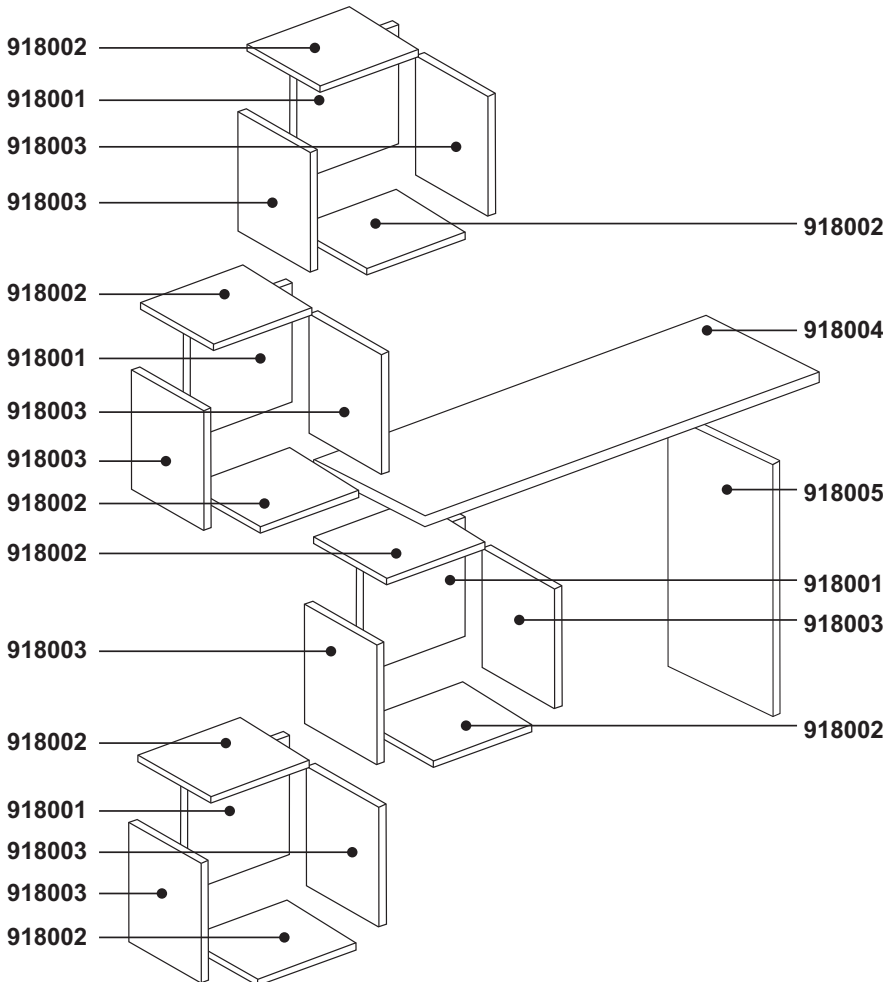
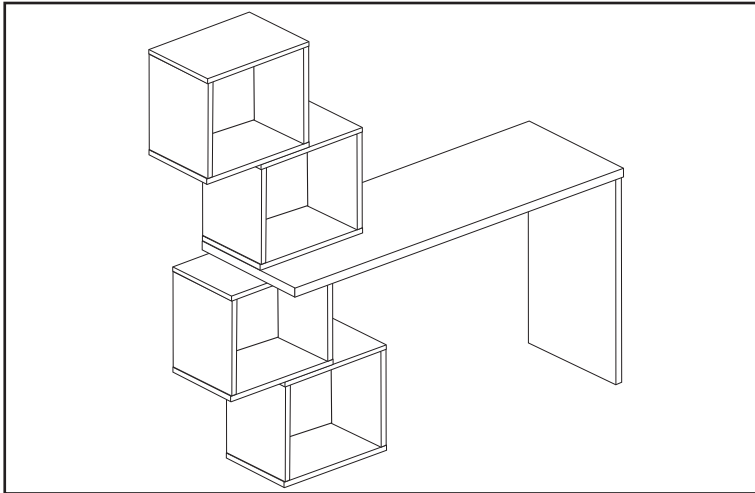
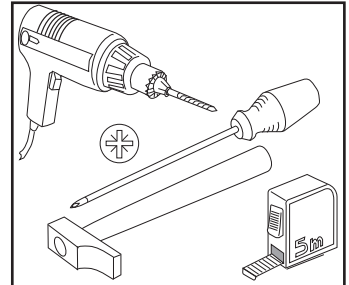

ANTES DE EMPEZAR CONSULTE LOS
CONSEJOS PARA EL MONTAJE.

AVANT DE COMMENCER
CONSULTEZ LES INSTRUCTIONS DE
MONTAGE.

BEFORE STARTING REFER TO THE
ASSEMBLY ADVICE.

VOR DEM BEGINN EMPFIEHLT ES
SICH AUFMERKSAM DIE HINWEISE
ZUR MONTAGE ZU LESEN.

ANTES DE COMEÇAR CONSULTE OS
CONSELHOS PARA A MONTAGEM.

RAADPLEEG VOORDAT U BEGINT
HET MONTAGE-ADVIES.

PRED ZACÁNÍM SE PROSÍM
MONTÁŽNÍ PORADENSTVÍ

اقرأ تعليمات التجميع بعناية.

x18	x16	x2	x58	x6	x8	x4	x6	x1	x1	x1	x18	x1
PE845	EX16	EX22	CL830	TSM	TP3530	TP3525	TP3515	ECG	COLA	TEMB18C	TE17RN	ET9393

Español (es) - Información importante sobre el montaje de los muebles en pared, leer detenidamente y guardar esta información para consultarla en el futuro.

ADVERTENCIA

Una vez montado según las instrucciones de montaje, el mueble está listo para fijarlo a la pared. Pueden producirse lesiones graves o fatales si vuelca un mueble. Para evitar que vuelque este mueble, debe fijarse permanentemente a la pared. Trasman Penedès no se hace responsable de daños personales ocasionados por un montaje de pared incorrecto.

No están incluidos los tornillos para montaje en pared. Póngase en contacto con su ferretero local que le asesorará en la elección del sistema de tornillos correcto para el tipo de material de pared, dado que los diversos materiales de pared requieren diferentes tipos de herrajes de fijación.

Français (fr) - Informations importantes concernant le montage mural de notre mobilier, a lire attentivement, conserver ces informations pour un usage ultérieur.

AVERTISSEMENT

Après avoir assemblé votre meuble en suivant le mode d'emploi, vous pouvez le monter au mur. Risque de blessure grave en cas de chute du meuble. Pour éviter que le meuble ne bascule, il faut le fixer au mur de façon permanente. Trasman Penedès décline toute responsabilité en cas de blessures ou de dommages matériels dus à un montage mural incorrect.

Aucune vis n'est fournie pour le montage mural. Contactez votre quincaillier local pour sélectionner une visserie adaptée au matériau de construction de votre mur, car leur choix dépend du matériau du mur sur lequel est fixé le meuble.

English (en) - Important information concerning wall mounting of furniture, read carefully and keep this information for further reference.

WARNING

After you have assembled this product according to the assembly instructions, it can be mounted on a wall. Serious or fatal crushing injuries can occur from furniture tip-over. To prevent this furniture from tipping over it must be permanently fixed to the wall. Trasman Penedès cannot be held liable for personal or material injury as a result of incorrect mounting.

Screws for wall mounting are not included. Please contact your local specialist to ensure the correct choice of screws in relation to the wall material since different wall materials require different types of fixing devices. Use fixing devices suitable for the walls in your home.

Deutsch (de) - Wichtige Information betr. Wandbefestigung des Schuhschranks, sorgfältig lesen, diese Information aufbewahren

ACHTUNG

Beim Zusammenbau dieses Schrankes müssen Sie das Möbelstück an der Wand befestigen.

Wenn Möbelstücke umkippen, können ernste oder lebensgefährliche Verletzungen durch Einklemmen die Folge sein. Um zu verhindern, dass das Möbelstück umkippt, muss es fest an der Wand verankert werden. Trasman Penedès haftet nicht für Personen- oder Sachschäden, die auf eine unsachgemäße Wandmontage zurückgeführt werden können.

Schrauben für die Wandmontage gehören nicht zum Lieferumfang. Für die korrekte Wahl eines für das jeweilige Wandmaterial geeigneten Schraubensystems wenden Sie sich bitte an den Fachhandel vor Ort, da dieses von der jeweiligen Wandbeschaffenheit abhängig ist.

Português (pt) - Informação importante relativa a montagem na parede do móvel, ler estas instruções cuidadosamente, guardar como referência.

IMPORTANTE

Depois de ter montado o móvel de acordo com as instruções de montagem, pode fixá-lo à parede. As quedas de móveis podem originar esmagamento ou morte. Estes móveis devem ser fixados à parede para evitar possíveis quedas. Trasman Penedès não se responsabiliza por ferimentos pessoais ou danos materiais ou danos como resultado da montagem incorrecta.

Os parafusos necessários para fixar o móvel à parede não estão incluídos. Por favor, contacte o seu especialista local para garantir a escolha correcta de parafusos em relação ao material, os diferentes tipos de parede requerem diferentes tipos de ferragens.

Italiano (it) - Informazioni importanti per il fissaggio alla parete dell'armadietto per le scarpe, leggi attentamente e conserva queste informazioni per ulteriori consultazioni.

AVVERTENZA

Durante il montaggio questo armadietto per le scarpe andrà fissato alla parete. Se il mobile si ribalta può causare lesioni da compressione serie o fatali. Per prevenire il rischio che il mobile si ribalti permanentemente alla parete. Trasman Penedès non potrà essere ritenuto responsabile dei danni a persone o cose dovuti ad un montaggio non corretto.

Le viti per il fissaggio a parete non sono in dotazione. Rivolgarsi al locale negoziante specializzato per essere sicuri che le viti corrispondano al materiale della parete perché pareti di materiali diversi richiedono tipi diversi di accessori di fissaggio

اللغة العربية - معلومات مهمة بخصوص التثبيت على الحائط الخاص بنا
الأثاث ، اقرأ بعناية ، احتفظ بهذه المعلومات لاستخدامها لاحقاً.
تحذير

بعد تجميع أثاثك باتباع تعليمات الاستخدام ، يمكنك تثبيته على الحائط. خطر الإصابة خطيرة في حال سقوط الأثاث. لمنع الخزانة من الانقلاب ، يجب تثبيتها على الحائط بشكل دائم. لا يمكن تحميل Trasman Penedès المسؤولية عن أي إصابات أو الضرر المادي بسبب التثبيت غير الصحيح على الحائط.

لا توجد براغي للتثبيت على الحائط. اتصل بمتجر الأجهزة المحلي لتحديد الأجهزة المناسبة لمواد بناء الحائط الخاص بك ، حيث يعتمد اختيارهم على مادة الحائط التي تم تركيب الأثاث عليها.

ESPAÑOL

CONSEJOS PARA EL MONTAJE:

- 1-ESTUDIE ATENTAMENTE EL MANUAL DE MONTAJE.
- 2-LOCALICE LAS PIEZAS QUE CONSTITUYEN SU MUEBLE.
- 3-REUNA Y CONTROLE LOS HERRAJES SUMINISTRADOS.
- 4-EQUIPESE CON LAS HERRAMIENTAS NECESARIAS.
- 5-PREPARE UNA ZONA DE MONTAJE.

CONSEJOS PARA EL MANTENIMIENTO:

- 1-QUITAR EL POLVO CUIDADOSAMENTE.
- 2-HUMEDECER UN PAÑO SUAVE Y LIMPIO CON AGUA LIGERAMENTE ENJABONADA.

NO FUERCE NUNCA EN LAS UNIONES APRIETE LOS TORNILLOS DESPUES DE CIERTO TIEMPO DE UTILIZACION. CONSERVE SU MANUAL DE MONTAJE.SI FALTARA UNA PIEZA SERIA LA MANERA MAS FACIL DE COMUNICARLO A LA TIENDA.

NO USE NUNCA PRODUCTOS ABRASIVOS TALES COMO: LANA DE ACERO , LIJAS,DISOLVENTES,ETC. NO MOJAR NI SOMETER A GRANDES HUMEDADES AL MUEBLE.

FRANCAIS

INSTRUCTIONS DE MONTAGE:

- 1-LISEZ ATTENTIVEMENT LA NOTICE DE MONTAGE.
- 2-REPEREZ LES PIECES QUI COMPOSENT VOTRE MEUBLE.
- 3-REGROUPEZ ET VERIFIEZ LES FERRURES FOURNIES.
- 4-DOTEZ-VOUS DES OUTILS NECESSAIRES.
- 5-PREPAREZ UN ESPACE DE MONTAGE.

CONSEILS D'ENTRETIEN:

- 1-ENLEVEZ SOIGNEUSEMENT LA POUSSIERE.
- 2-HUMIDIFIEZ UN CHIFFON DOUX ET PROPRE AVEC DE L'EAU LEGEREMENT SAVONNEUSE.

LES MEUBLES CONTENANT DES PANNEAUX À BASE DE BOIS (PANNEAUX DE PARTICULES, PANNEAUX DE FIBRES, CONTREPLAQUÉ...) PEUVENT ÉMETTRE DES SUBSTANCES POLLUANTES DANS L'AIR INTÉRIEUR. IL EST AINSI RECOMMANDÉ, APRÈS L'INSTALLATION DU MEUBLE DANS SON LOGEMENT, D'AÉRER FRÉQUEMMENT LA PIÈCE CONCERNÉE PENDANT AU MOINS QUATRE SEMAINES AFIN DE RÉDUIRE SON EXPOSITION AUX POUILLANTS ÉMIS PAR LE MEUBLE.

NE FORCEZ JAMAIS LES RACCORDS. RESSERREZ LES VIS APRES UN CERTAIN TEMPS D'UTILISATION. CONSERVEZ LA NOTICE DE MONTAGE.EN CAS DE PIECE MANQUANTE , CE SERA LE MEILLEUR MOYEN D'EN INFORMER LE MAGASIN.

N'UTILISEZ JAMAIS DES PRODUITS ABRASIFS COMME DE LA LAINE D'ACIER, DU PAPIER DE VERRE, DES SOLVANTS, ETC. NE MOUILLEZ PAS LE MEUBLE ET EVITEZ TOUTE ESPOSITION A UNE HUMIDITE IMPORTANTE.

ENGLISH

ASSEMBLY ADVICE:

- 1- STUDY THE ASSEMBLY MANUAL CAREFULLY.
- 2- LOCATE THE PARTS THAT COMPRISE YOUR FURNITURE ITEM.
- 3- ORGANISE AND CHECK THE FITTINGS SUPPLIED.
- 4- HAVE THE NECESSARY TOOLS TO HAND.
- 5- PREPARE AN ASSEMBLY AREA.

MAINTENANCE ADVICE:

- 1- REMOVE DUST CAREFULLY.
- 2- MOISTEN A SOFT, CLEAN CLOTH WITH SLIGHTLY SOAPY WATER.

DO NOT FORCE ANY OF THE JOINTS. TIGHTEN THE SCREWS AFTER HAVING USED THE FURNITURE FOR SOME TIME. KEEP YOUR ASSEMBLY MANUAL. IF ANY PART IS MISSING, IT WILL HELP YOU TO LET THE SHOP KNOW.

NEVER USE ABRASIVE PRODUCTS SUCH AS STEEL WOOL, SANDPAPER, ETC. DO NOT WET THE FURNITURE OR KEEP IT IN A VERY DAMP PLACE.

DEUTSCH

HINWEISE ZUR MONTAGE:

- 1- LESEN SIE AUFMERKSAM DIE MONTAGEANLEITUNG DURCH.
- 2- LOCALISIEREN SIE DIE ZUM MÖBEL GEHÖRENDE TEILE.
- 3- KONTROLLIEREN SIE DIE MITGELIEFERTEN WERKZEUGE.
- 4- RÜSTEN SIE SICH MIT DEN ZUSÄTZLICH BENÖTIGTEN WERKZEUGEN AUS.
- 5- BEREITEN SIE EINEN PLATZ FÜR DIE MONTAGE VOR.

HINWEISE ZUR PFLEGE:

- 1- ENTFERNEN SIE UMSICHTIG DEN ANGESAMMELTEN STAUB.
- 2- VERWENDEN SIE EIN WEICHES UND SAUBERES TUCH UND SCHWACHE SEIFENLAUGE.

FORCIEREN SIE NIEMALS DIE VERBINDUNGEN. ZIEHEN SIE DIE SCHRAUBEN NACH EINER BESTIMMTEN NUTZUNGSZEIT NACH. BEWAHREN SIE DIE MONTAGEANLEITUNG AUF. SOLLTE EIN TEIL FEHLEN IST SIE VON GROSSER WICHTIGKEIT BEI DER NACHBESTELLUNG IM LADEN.

VERWENDEN SIE NIEMALS SCHEUERENDE PRODUKTE WIE STAHLWOLLE, SCHMIRGELPAPIER, LÖSUNGSMITTEL UND DERGL. WASSER UND HOHE FEUCHTIGKEIT SIND SCHÄDLICH FÜR DAS MÖBEL.

POTUGUES

CONSELHO PARA A MONTAGEM :

- 1 - ESTUDE ATENTAMENTE O MANUAL DE MONTAGEM.
- 2 - LOCALIZE AS PEÇAS QUE CONSTITUEM O SEU MÓVEL.
- 3 - REUNA E CONTROLE AS FERRAGENS FORNECIDAS.
- 4 - EQUIPE-SE COM AS FERRAMENTAS NECESSÁRIAS.
- 5 - PREPARE UMA ZONA DE MONTAGEM.

CONSELHOS PARA A MANUTENÇÃO :

- 1- RETIRAR A POEIRA COM CUIDADO.
- 2- HUMEDECER UM PANO SUAVE E LIMPO COM ÁGUA LIGEIRAMENTE ENSABOADA.

NUNCA FORCE AS UNIÕES. APORTE OS PARAFUSOS DEPOIS DE DETERMINADO TEMPO DE UTILIZAÇÃO.. CONSERVE O SEU MANUAL DE MONTAGEM, SE FALTAR UMA PEÇA SERIA A MANEIRA MAIS FÁCIL DE A COMUNICAR À LOJA.

NUNCA USE PRODUTOS ABRASIVOS TAIS COMO : LÃ DE AÇO, LIXAS, DISSOLVENTS, ETC.. NÃO MOLAR NEM SUBMETTER A GRANDES HUMIDADES, O MÓVEL.

ITALIANO

CONSIGLI PER IL MONTAGGIO:

- 1- STUDIARE ATTENTAMENTE IL MANUALE DI MONTAGGIO.
- 2- INDIVIDUARE LE PARTI CHE COSTITUISCONO IL MOBILE.
- 3- RACCOGLIERE E CONTROLLARE GLI ATTREZZI IN DOTAZIONE.
- 4- PROCURARSI GLI ATTREZZI NECESSARI.
- 5- PREPARARE UNA ZONA PER IL MONTAGGIO.

CONSIGLI PER LA MANUTENZIONE:

- 1- SPOLVERARE ACCURATAMENTE.
- 2- INUMIDIRE UN PANNINO MORBIDO E PULITO CON ACQUA E POCO DETERGENTE.

NON FORZARE MAI LE GIUNTURE. STRINGERE NUOVAMENTE LE VITI DOPO UN CERTO PERIODO D'USO. CONSERVARE IL MANUALE DI MONTAGGIO: SE MANCASSE UN PEZZO SAREBBE COSÌ PIÙ FACILE COMUNICARLO AL RIVENDITORE.

NON USARE MAI PRODOTTI ABRASIVI COME: SPUGNE ABRASIVE, CARTA VETRATA, SOLVENTI, ECC. NON BAGNARE NE' SOTTOPORRE IL MOBILE A FORTE UMIIDITÀ.

اللغة العربية

تعليمات التجميع:

- 1-اقرأ تعليمات التجميع بعناية.
- 2-حدد موقع الأجزاء التي يتكون منها أثاثك.
- 3-الجمع والتحقق من الأجهزة المقدمة.
- 4-هل لديك الأدوات اللازمة.
- 5- جهز مساحة التركيب.

إرشادات الصيانة:

- 1-قم بإزالة الغبار بعناية.
- 2-قم بتطهير قطعة قماش ناعمة ونظيفة بالصابون الخفيف والماء.

لا تفرض التركيبات أبداً. شد البراغي بعد وقت معين من الاستخدام. احفظ تعليمات التجميع. في حالة وجود جزء مفقود ، ستكون هذه أفضل طريقة لإعلام المتجر.

لا تستخدم أبداً المنتجات الكاشطة مثل الصوف الصلب ، ورق الرمل ، والمذيبات ، وما إلى ذلك. لا تبلل الأثاث وتجنب أي تعرض للرطوبة العالية.

1/2

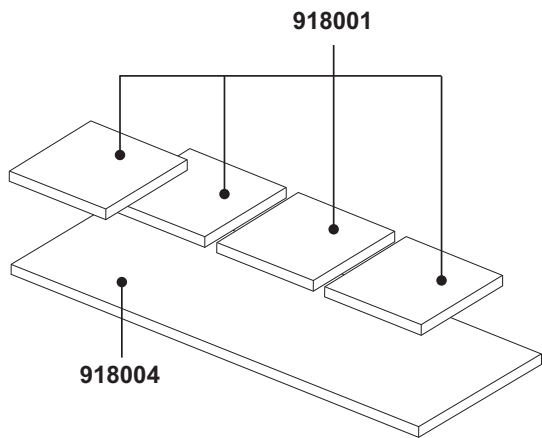

9180A

2/2



T1 T2
X Y

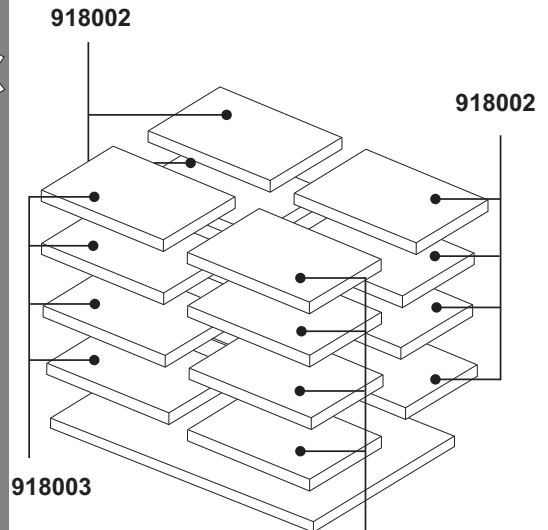

9180B

HERRAJES

FERRURES

MÖBELBESCHLÄGE

ACCESSORI
PER MOBILI

FERRAGENS

OKUCIA
MEBLOWE

FURNITURE
FITTINGS

T1



x18

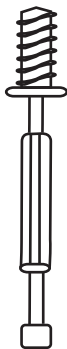

PE845

x2



EX22

x16

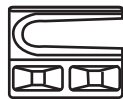

EX16

x58



CL830

x6

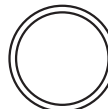
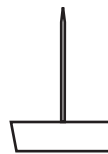

TSM

x8



TP3530

x4



TP3525

x6



TP3515

X



x1



COLA

x2

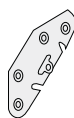

ECG

Y



x1

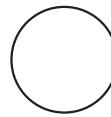

TEMB18C

x18



TE17RN

x1

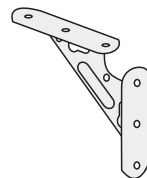

ET9393

1

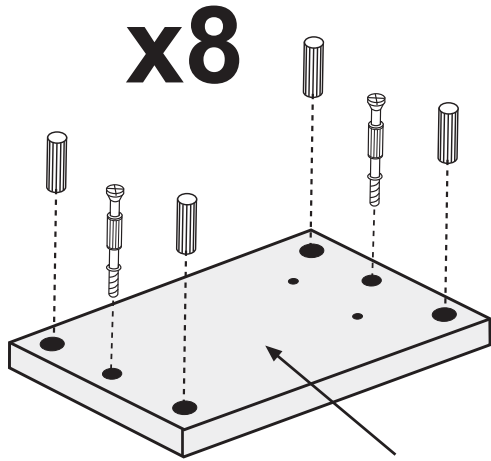

918002

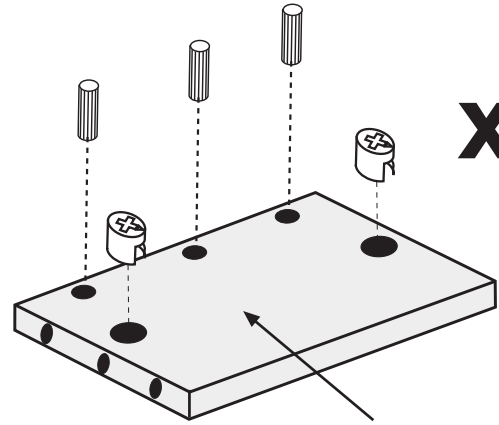
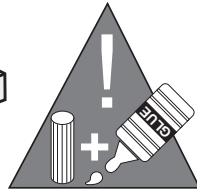

918003

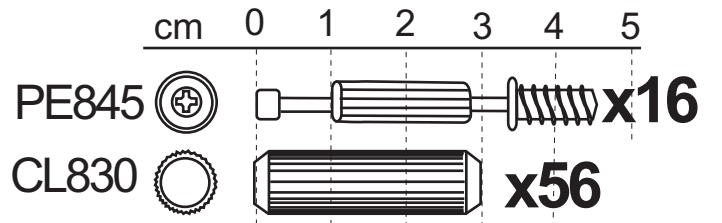
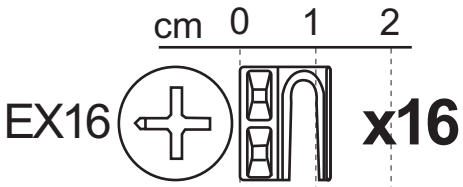

2

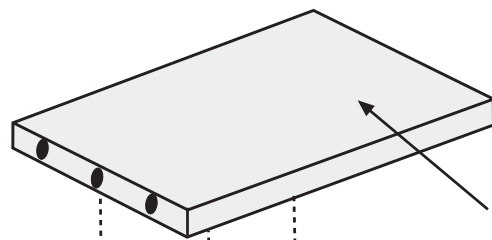

918003

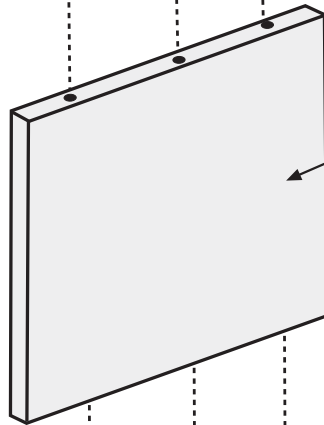

918001

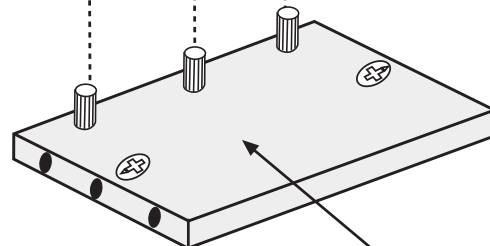

918003

a

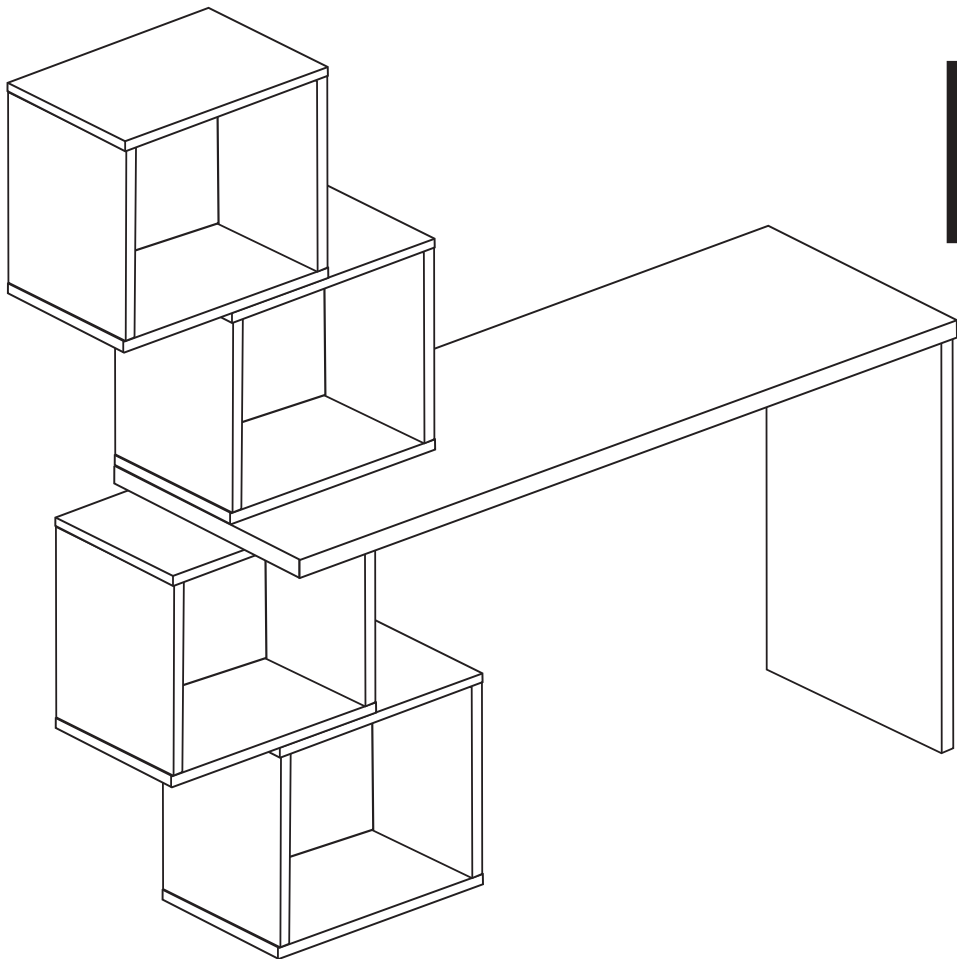
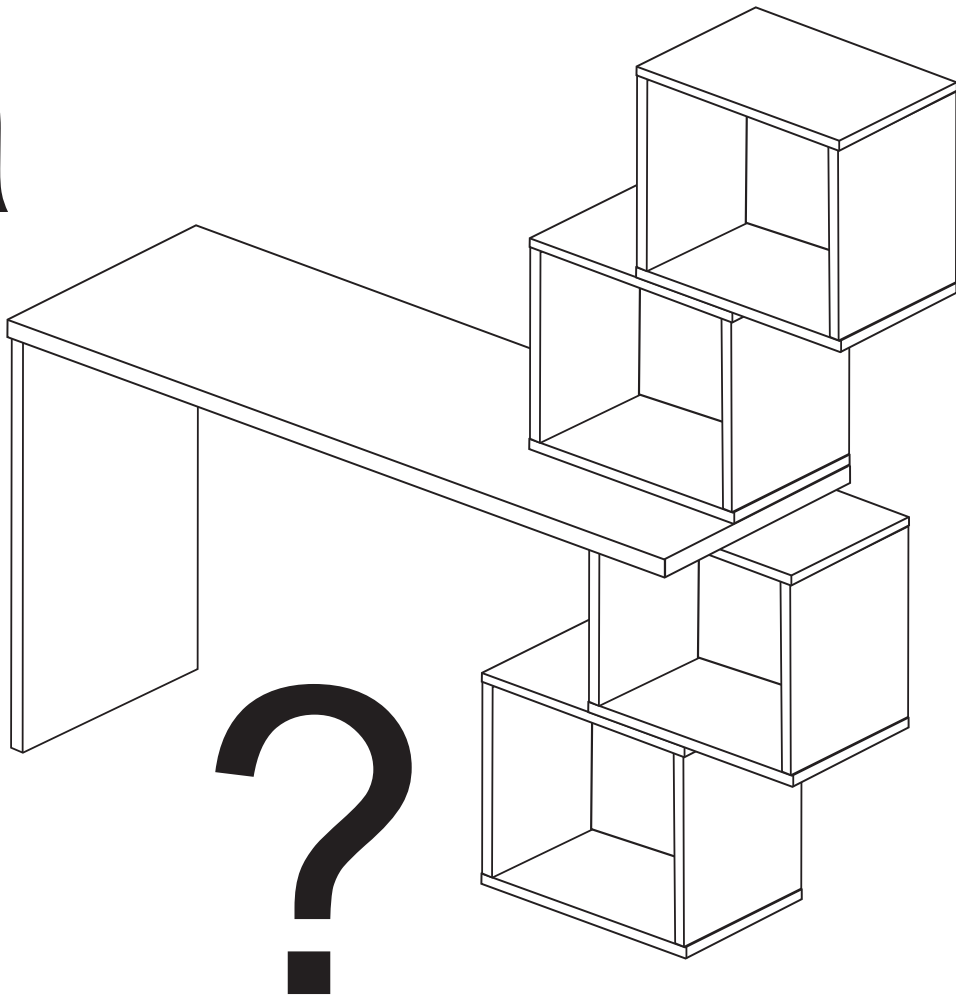

b

3a

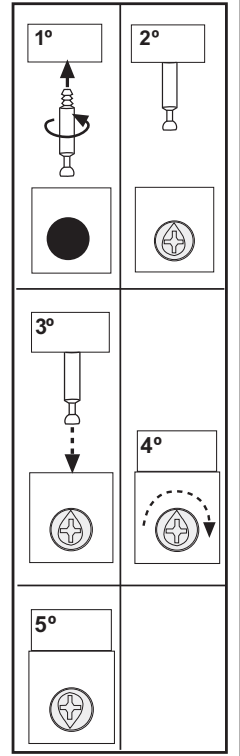
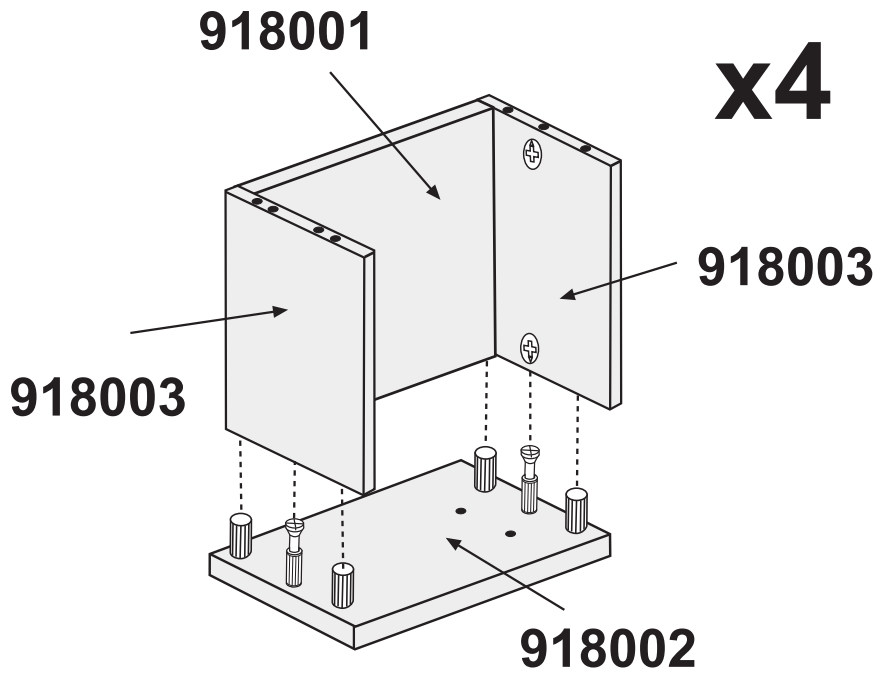

x16





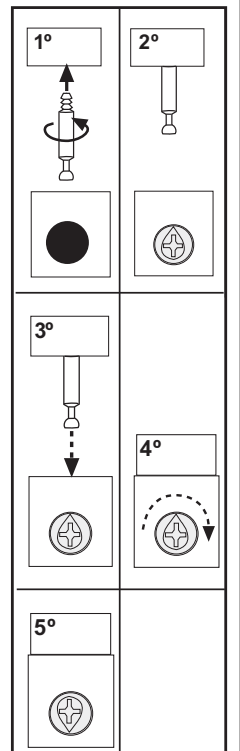
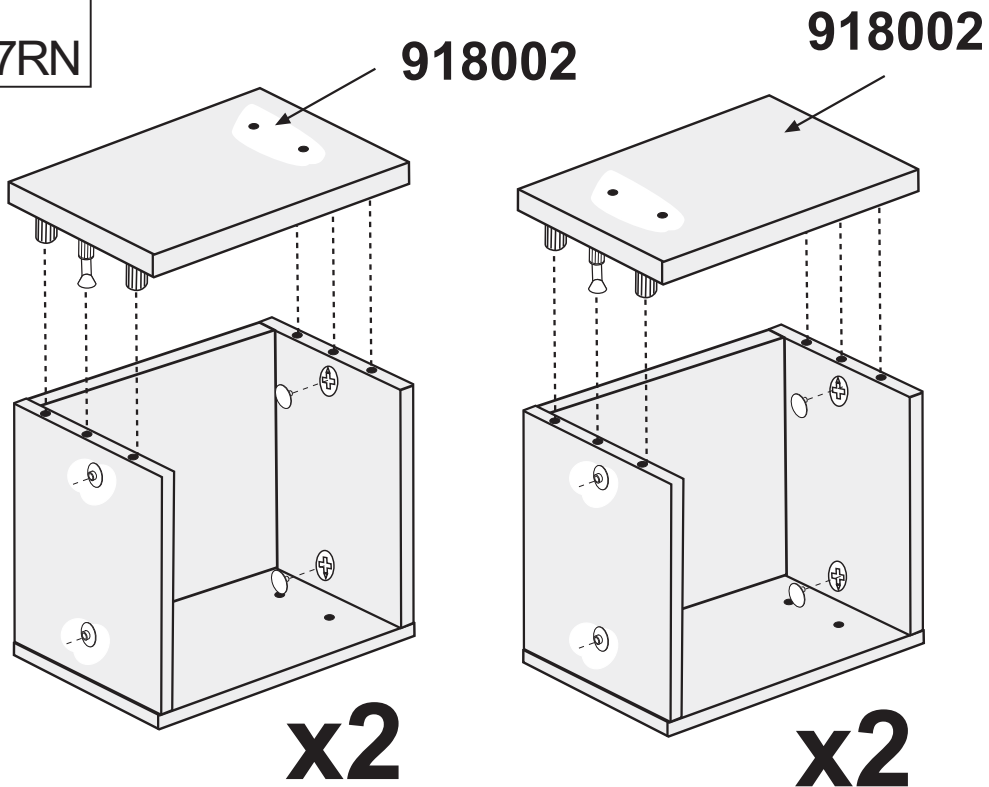

TE17RN



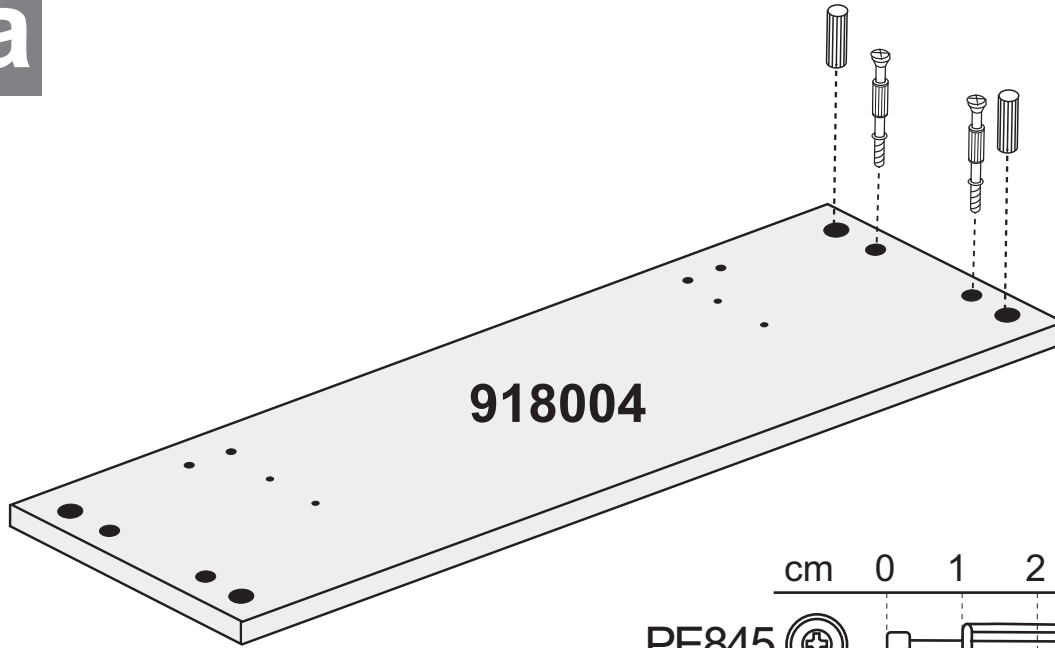

4a

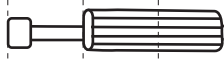
5a



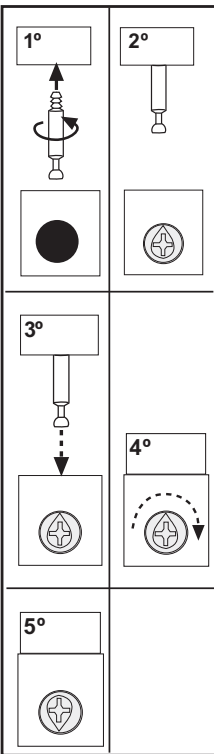

- cm 0 1 2 3 4 5
- PE845   x2
- CL830   x2

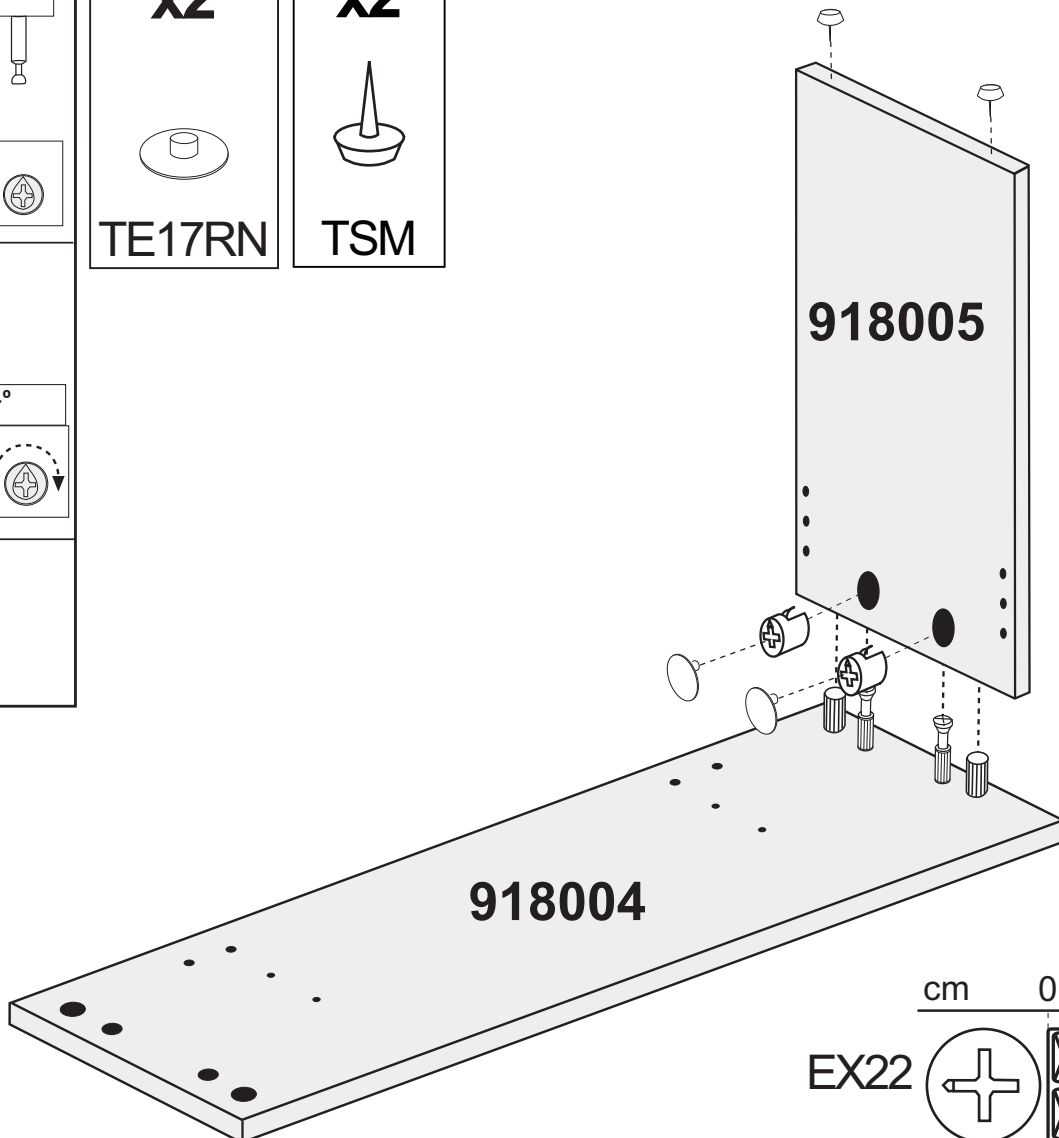

- x2  TE17RN
- x2  TSM

6a



- cm 0 1 2
- EX22   x2

7a

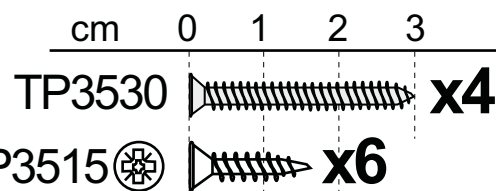
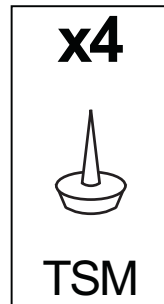
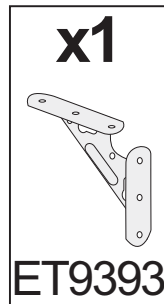
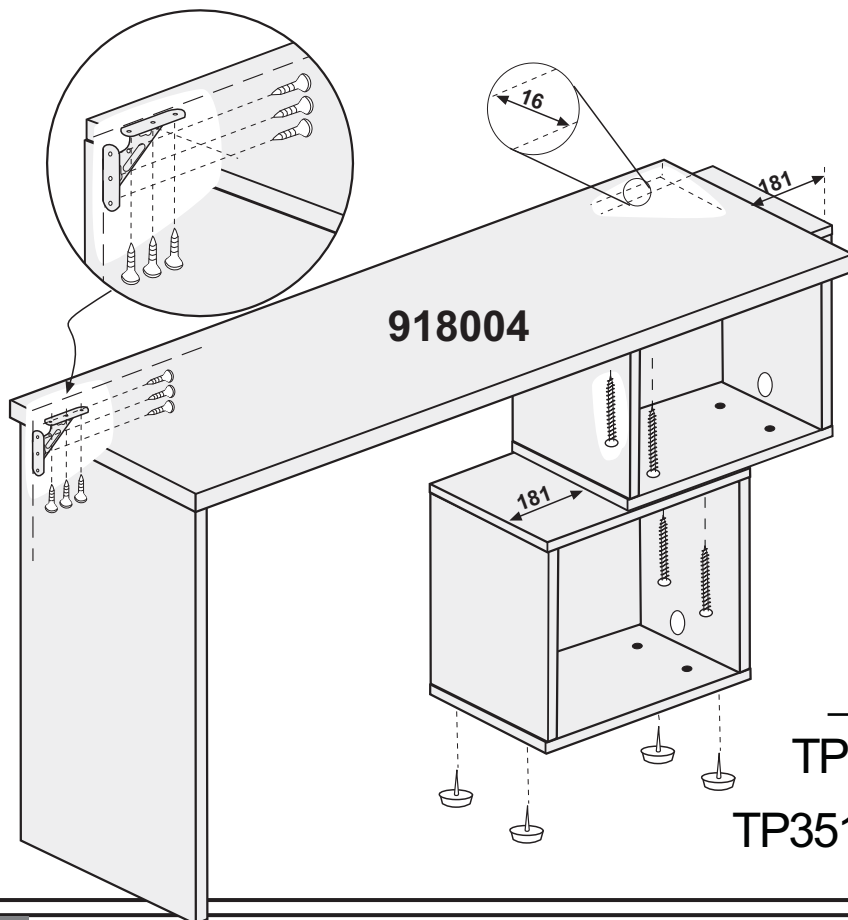

8a

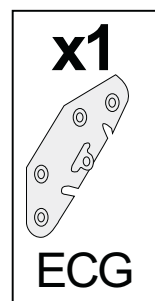

No incluido
Not included
Pas inclus

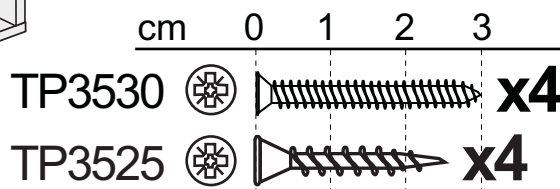
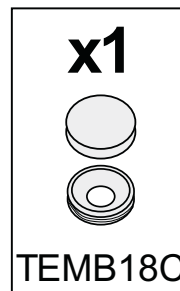
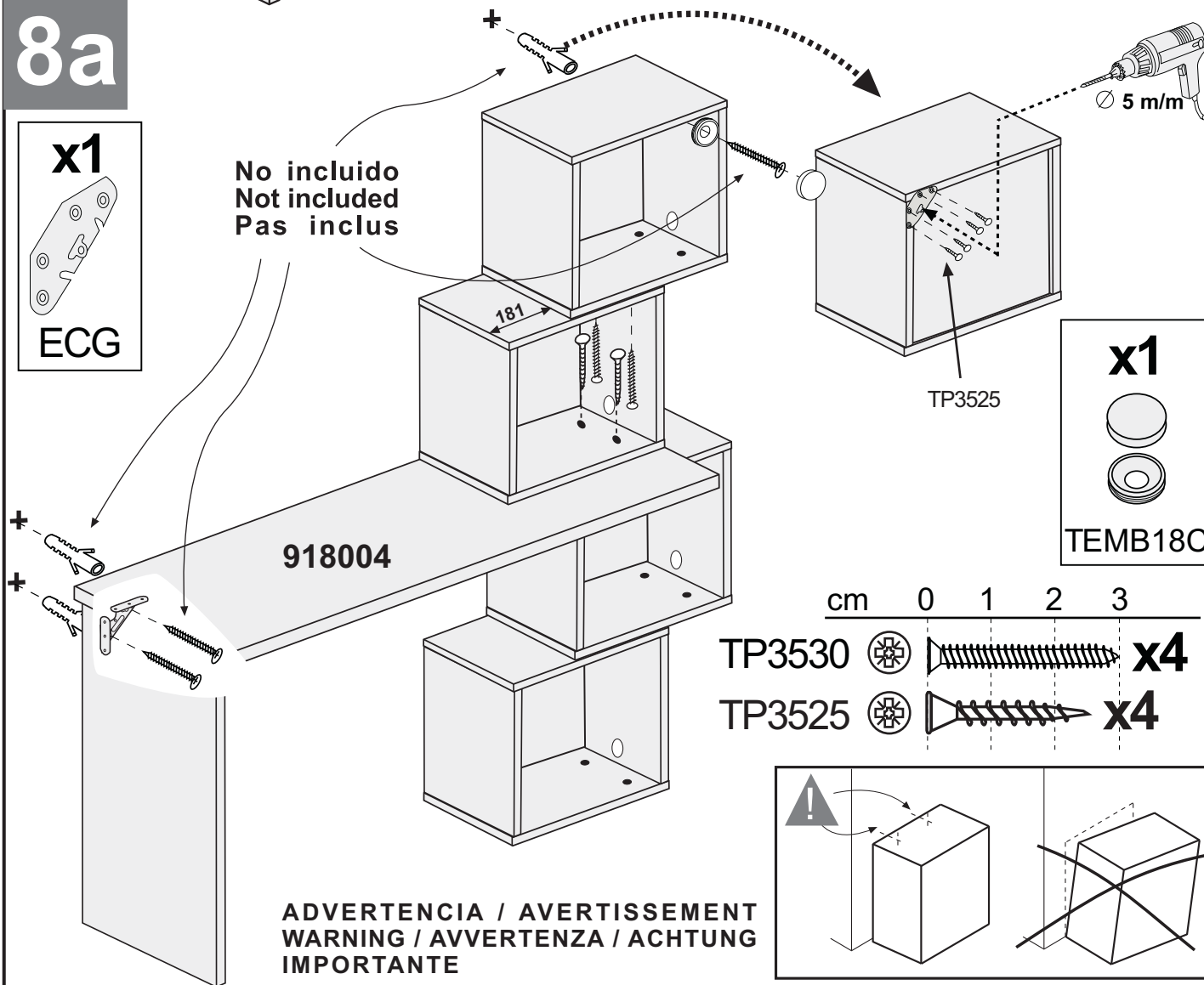

ADVERTENCIA / AVERTISSEMENT
WARNING / AVVERTENZA / ACHTUNG
IMPORTANTE

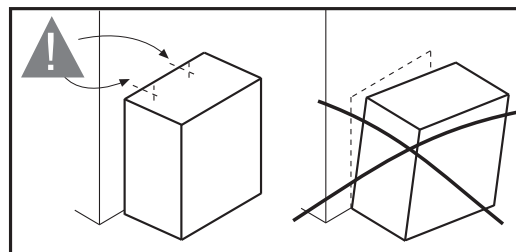

3b

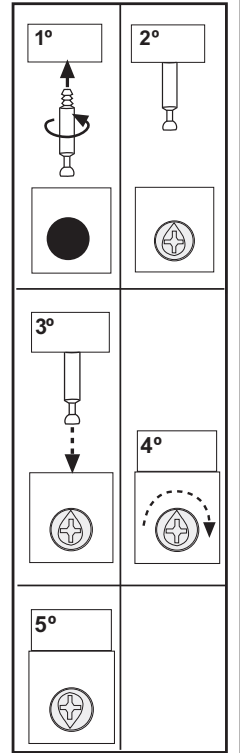
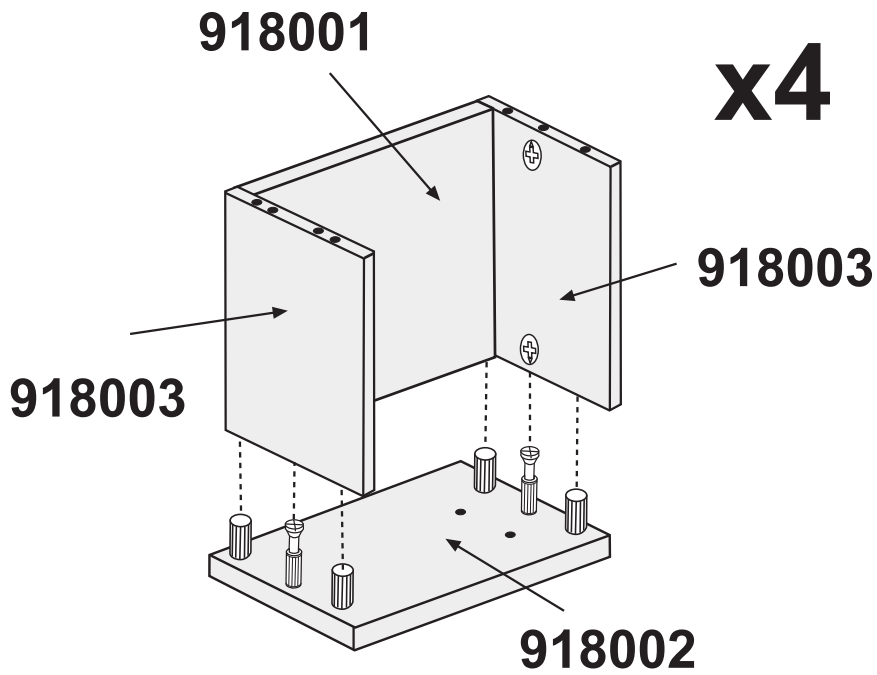

x16



TE17RN

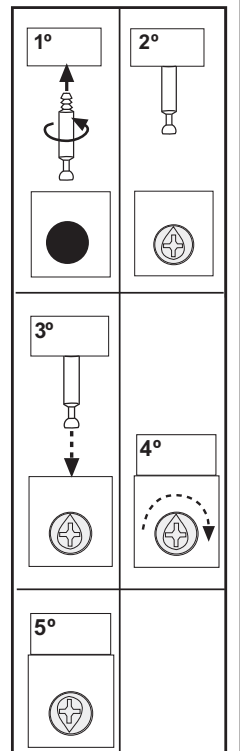
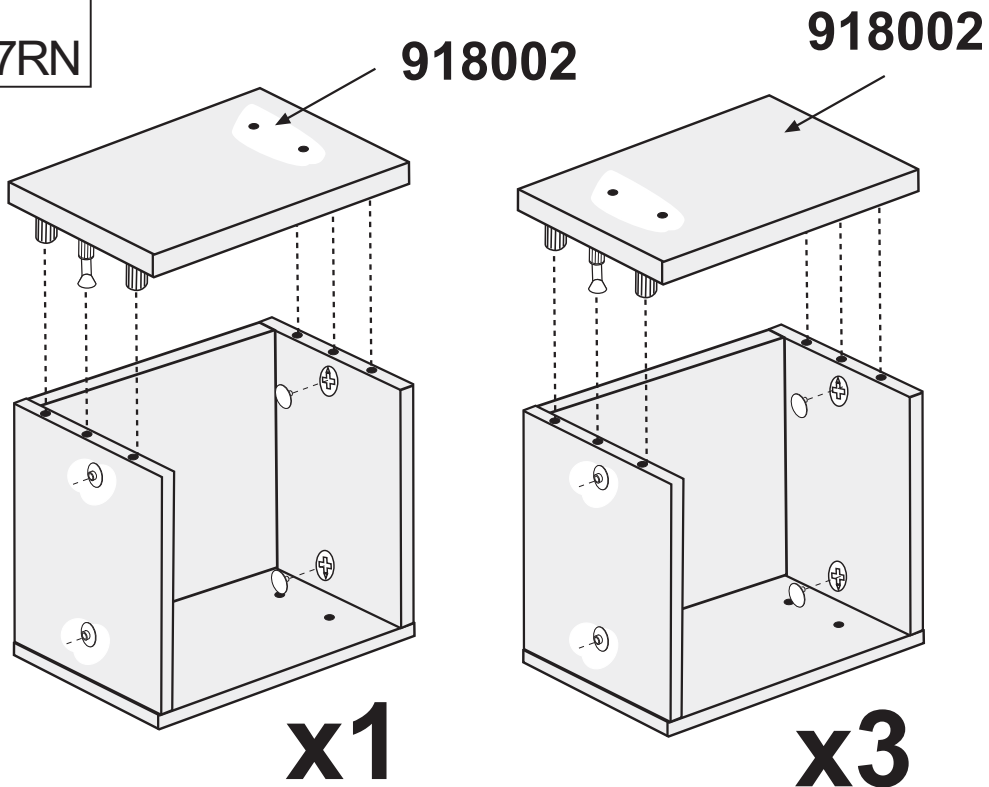

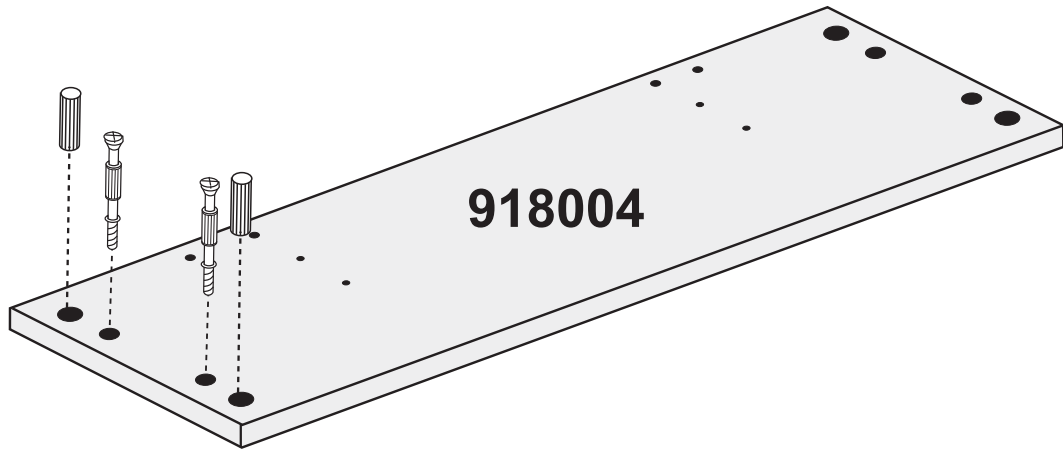

4b

5b



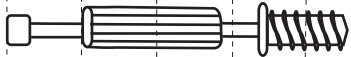

cm 0 1 2 3 4 5

- PE845   x2
- CL830   x2

6b

cm 0 1 2

- EX22   x2

x2



TSM

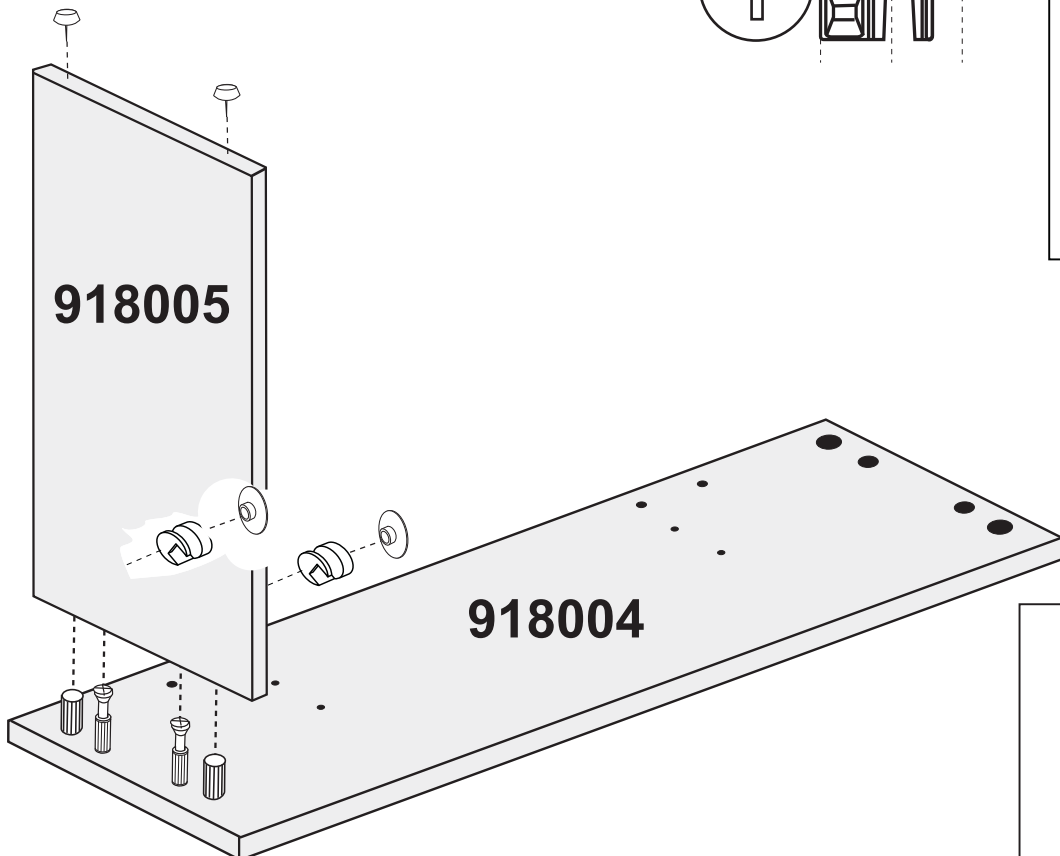

x2



TE17RN

7b

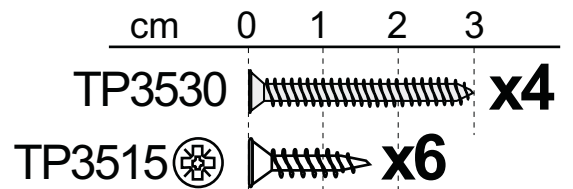
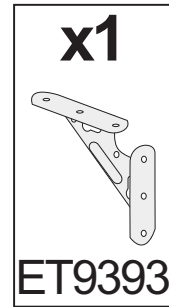
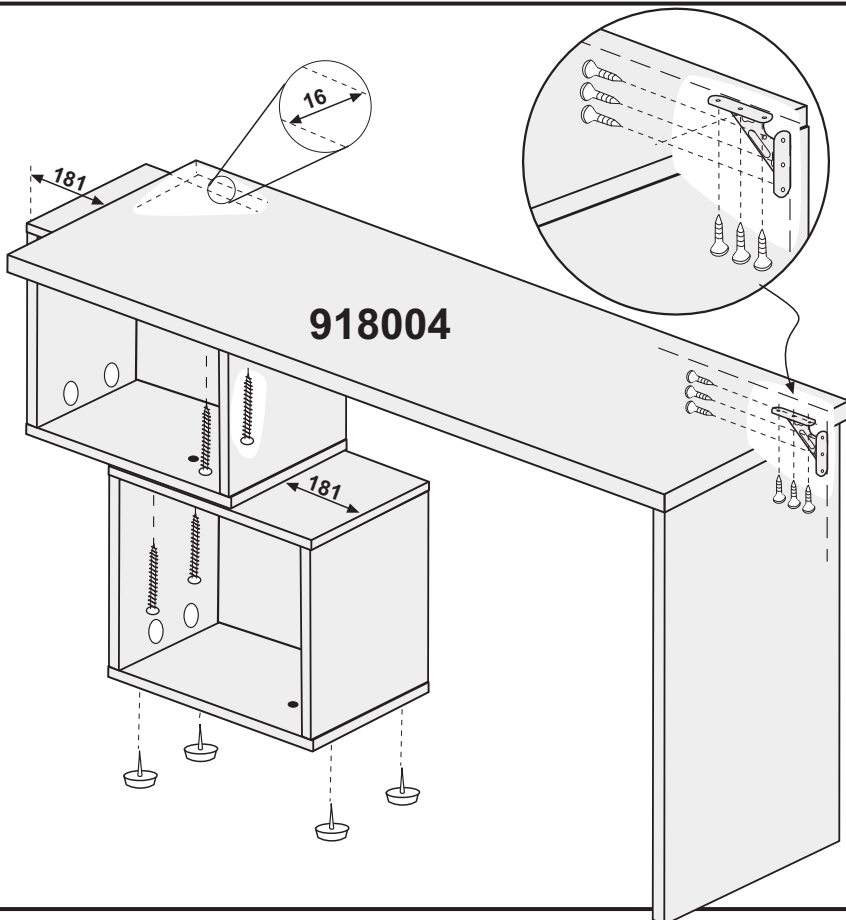

8b

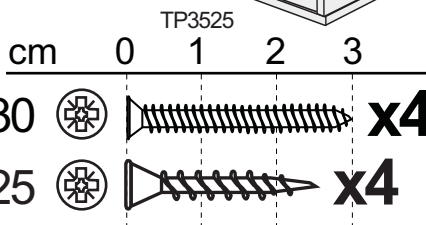
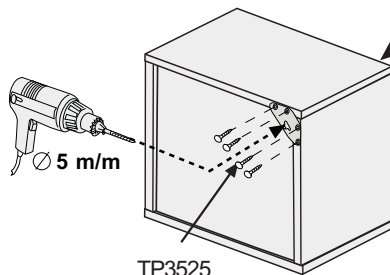

No included
Not included
Pas inclus

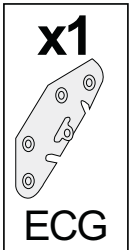

ADVERTENCIA / AVERTISSEMENT
WARNING / AVVERTENZA / ACHTUNG
IMPORTANTE

