

veito

CARBON INFRARED HEATER

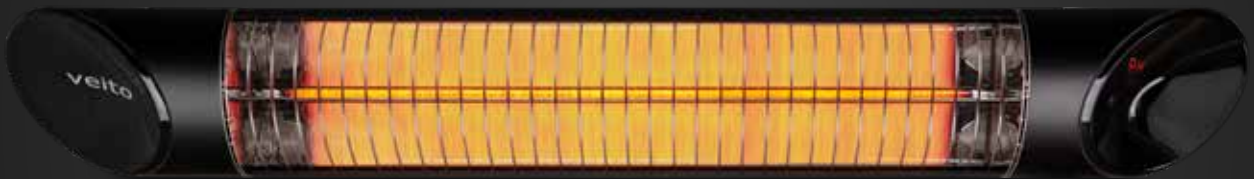

Blade

veito

veito

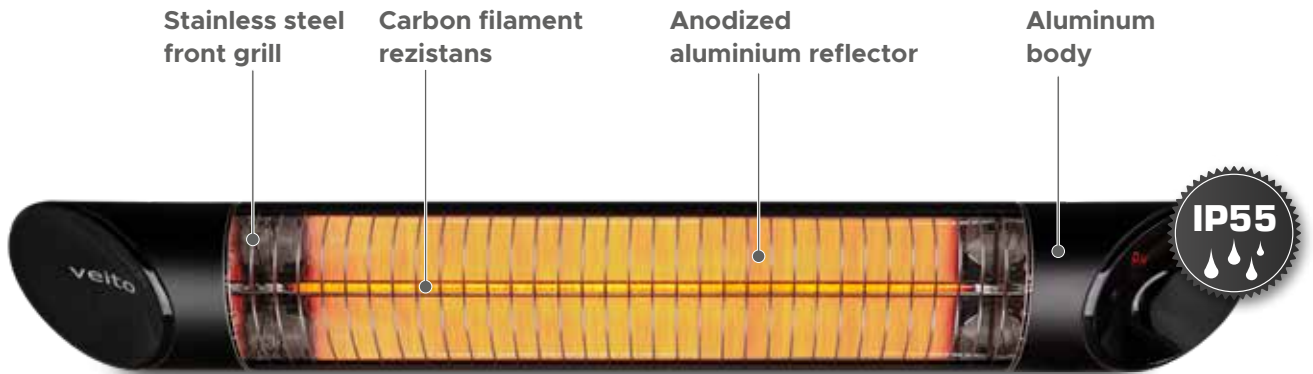

ZERO noise
odor
greenhouse gases

BLADE S

Height	130 mm
Width	930 mm
Depth	90 mm
Line voltage	220-240V AC
Frequency	50/60Hz, single phase
Maximum power	2500W
IP rating	IP55

BLADE

Height	130 mm
Width	930 mm
Depth	90 mm
Line voltage	220-240V AC
Frequency	50/60Hz, single phase
Maximum power	2000W
IP rating	IP55

BLADE MINI

Height	130 mm
Width	730 mm
Depth	90 mm
Line voltage	220-240V AC
Frequency	50/60Hz, single phase
Maximum power	1200W
IP rating	IP55

CARBON INFRARED HEATER

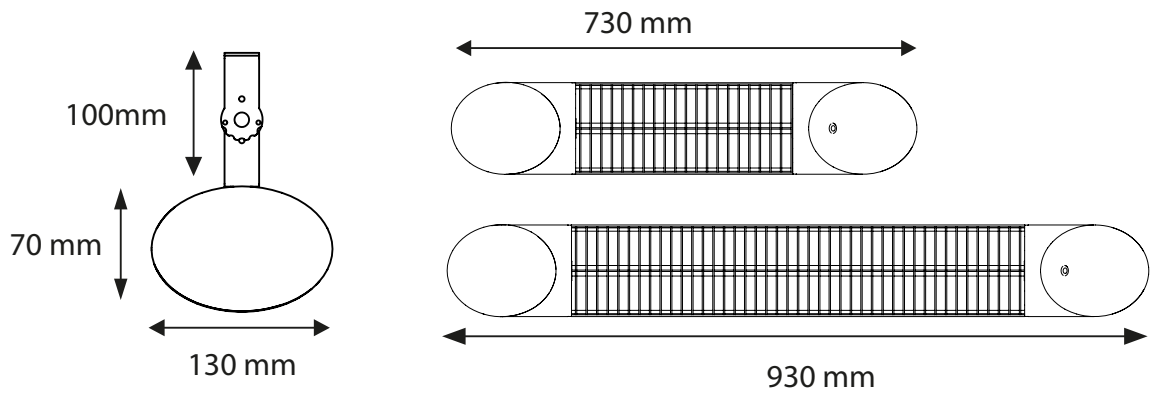

DIGITAL THERMOSTAT



FROM REMOTE CONTROL



BLADE / BLADE S

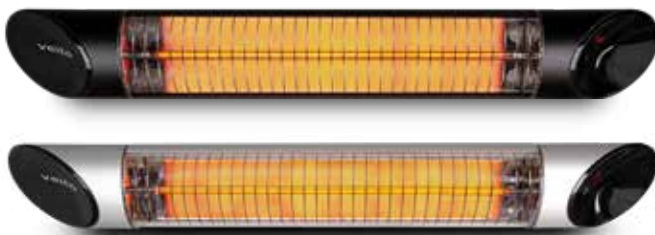

BLADE MINI

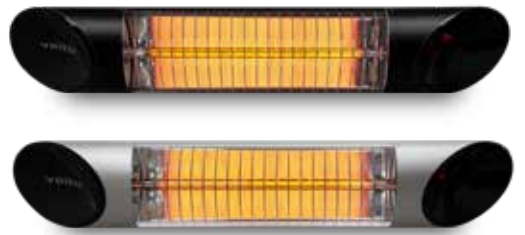



THE BLADE

Carbon infrared heater generates low-glare, medium-wave infrared heat. Its comfortable warmth is quickly distributed over a wide area, thanks to a specially designed reflector. The wavelength of the emitted light enables the heat to travel long distances, transforming into a pleasant warmth. The heating intensity can be easily adjusted using the remote control. This innovative heater operates with exceptional energy efficiency, eliminating the need for additional insulation. As a result, it not only reduces energy costs but also provides a consistent and comfortable environment year-round.



veito

CARBON INFRARED HEATER

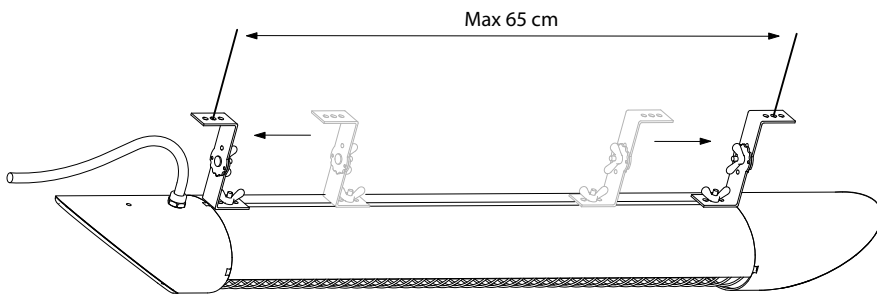
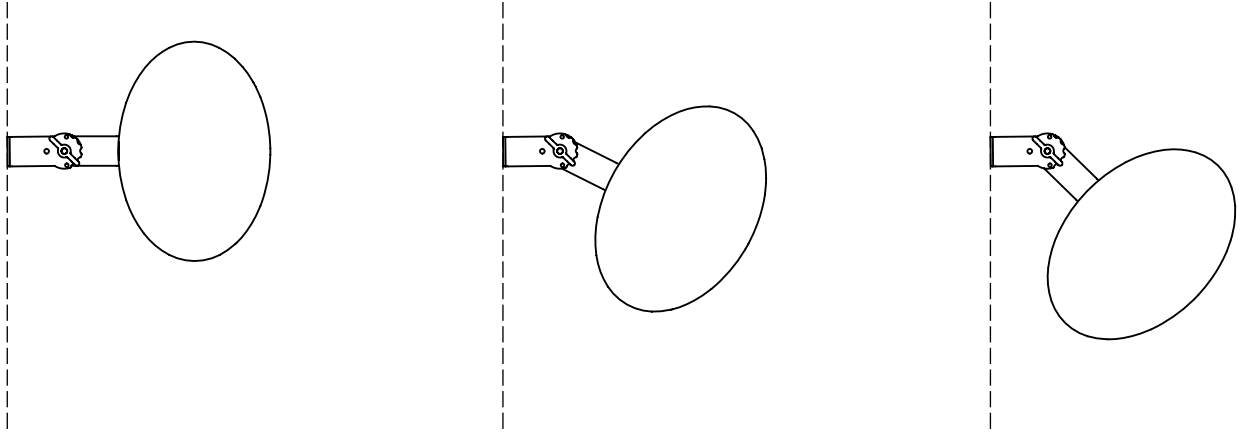

OUTDOOR COVERAGE AREA

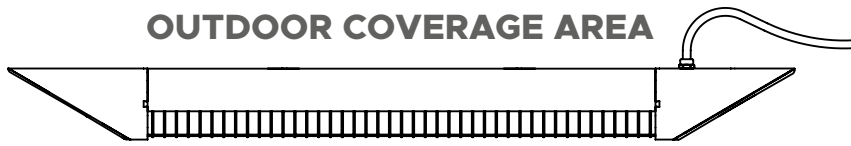

AVERAGE 10M²

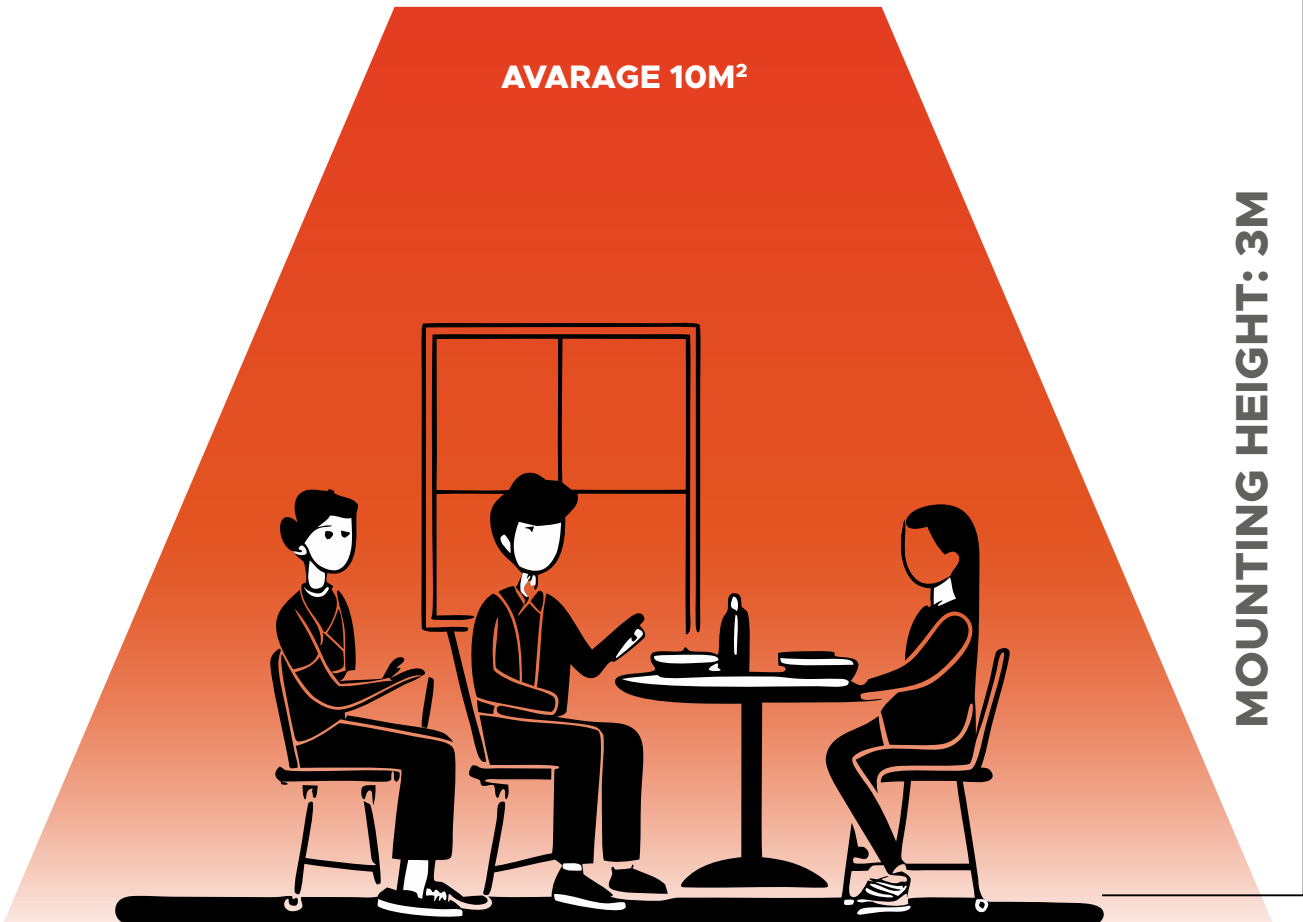

MOUNTING HEIGHT: 3M

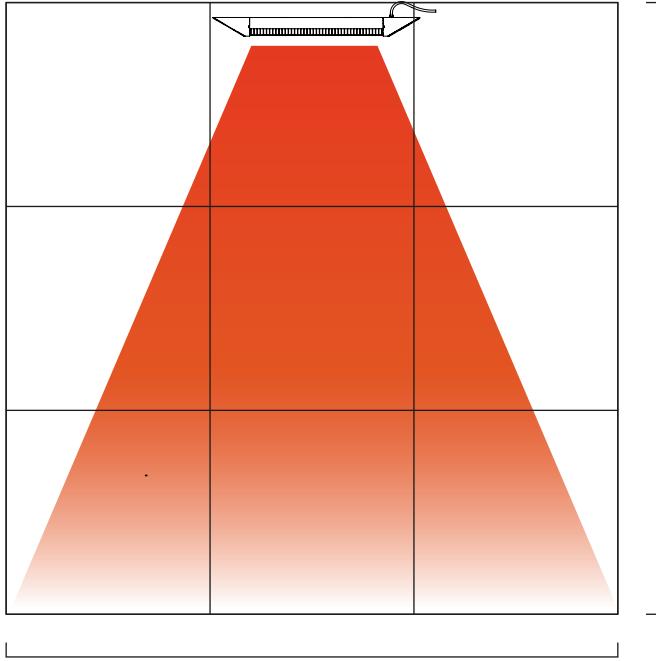
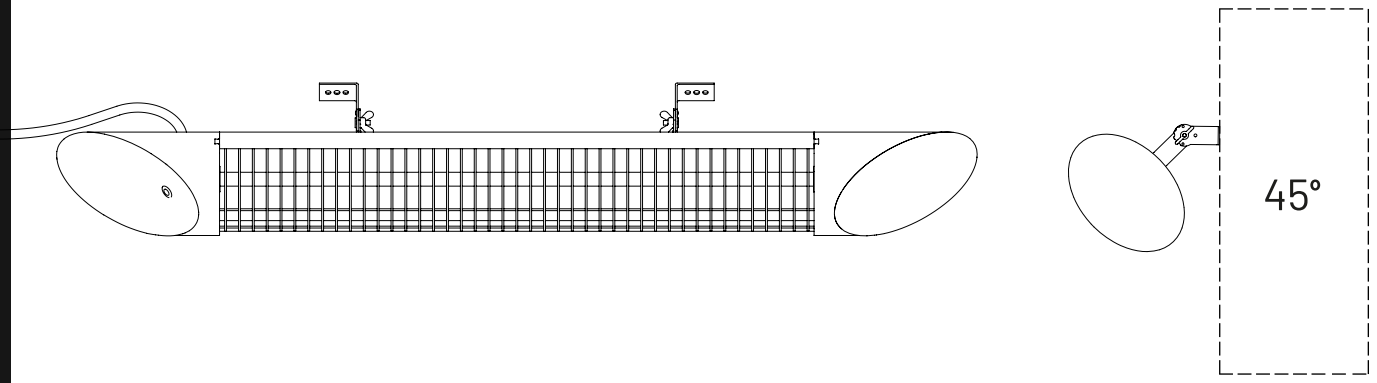

3 m

3 m

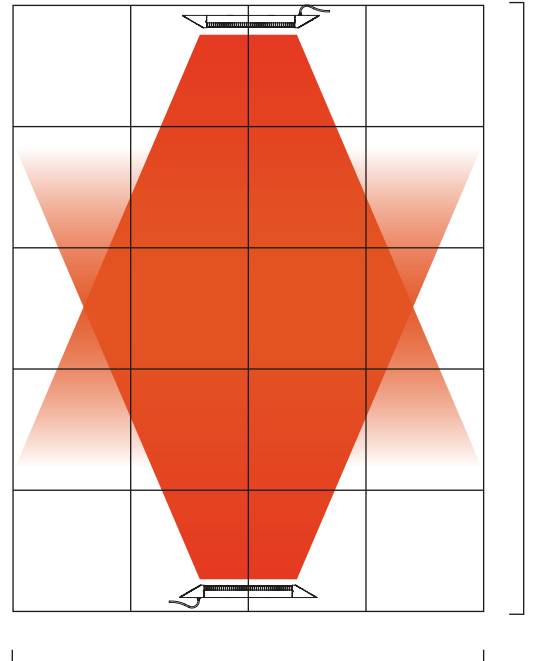

4 m

5 m

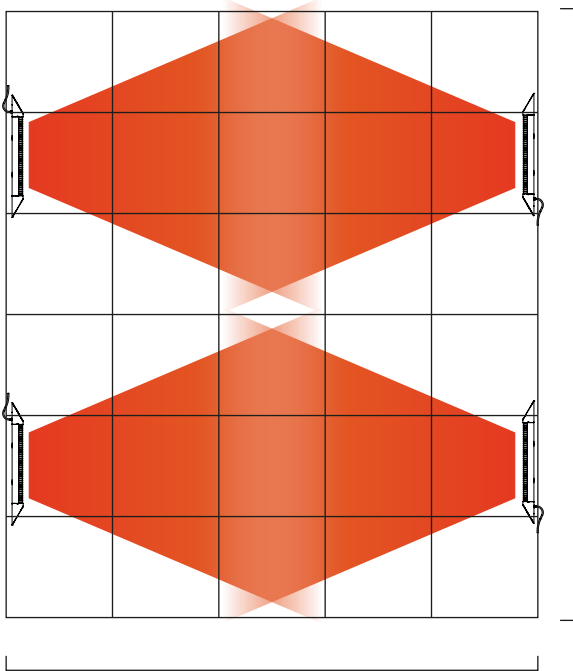

5 m

6 m

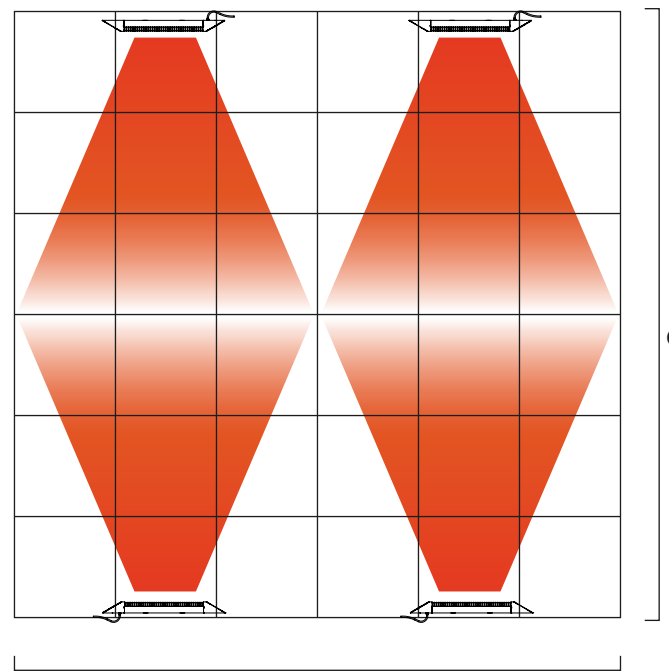

6 m

6 m

veito

Blade

CARBON INFRARED HEATER