

SELECT   
COMPOSITE

# A REALLY EASY GUIDE TO YOUR NEW DECK



Greener option



Weather resistant



Impact resistant



Low maintenance



No warping, no splitting



Insect resistant

# Contents

INTRODUCTION.....	3
-------------------	---

## BEFORE YOU GET STARTED

<b>1. Shopping list.....</b>	<b>7</b>	<b>3. Planning.....</b>	<b>10</b>
<b>2. Storage and handling.....</b>	<b>8</b>	3.1 Preparing the area.....	10
2.1 Storage.....	8	3.2 Calculating materials.....	11
2.2 Handling.....	9		

## LAYING YOUR DECKING

<b>4. Sub-frame installation.....</b>	<b>15</b>	<b>Premium / Supreme only</b>	
4.1 About the sub-frame.....	15	Bullnose boards.....	44
4.2 Building a sub-frame on flat concrete surface.....	16	<b>Advanced techniques</b>	
4.3 Building a sub-frame on soft uneven surface.....	18	Diagonal boards.....	46
4.4 Fitting joists end-to-end (butt-jointing).....	21	Picture framing.....	49
4.5 Sister joists.....	22	<b>6. Finishing touches.....</b>	<b>52</b>
4.6 Using deck tape.....	23	6.1 About finishing boards.....	52
4.7 Using support pedestals.....	24	6.2 Installing fascias/skirting boards.....	53
4.8 Using slope correctors.....	35	6.3 Installing corner trim boards.....	54
<b>5. Decking installation.....</b>	<b>36</b>	<b>Advanced technique</b>	
5.1 Fitting the first board.....	36	Steps.....	55
5.2 Fitting subsequent boards.....	38		
5.3 Fitting the end board.....	40		
5.4 Fitting boards end-to-end (butt-jointing).....	43		

## CARE AND SUPPORT

<b>8. Maintenance.....</b>	<b>58</b>	<b>9. FAQs.....</b>	<b>59</b>
----------------------------	-----------	---------------------	-----------

# Introduction

**Congratulations on taking the first step towards your brand new deck.**

Composite decking is a great way to easily install stunning, environmentally friendly decking at your home or business.

The advanced design allows you to simply clip boards together on a frame, thus ensuring consistent spacing between boards every time.

## **WHAT IS WPC?**

WPC (wood plastic composite) is a hybrid product made of wood and plastic to produce

a durable composite material. 90% of the materials that go in to make WPC are recycled.

**No new trees are cut down and waste plastic is removed from our environment.**

## **HOW DOES IT WORK?**

Your decking sits on a robust sub-frame made up of joists. Clips are secured to the joists at regular intervals.

Your decking boards have grooves cut into them that perfectly fit into the clips, securely attaching your boards in place.



**GREENER OPTION**



**WEATHER RESISTANT**



**IMPACT RESISTANT**



**EASY INSTALL, LOW MAINTENANCE**



**NO WARPING, NO SPLITTING**



**INSECT RESISTANT**

## OUR DECKING RANGES

Our decking components are designed to be used with other items from the same range.

### Core

146mm x 25mm x 3600mm

146mm x 25mm x 5000mm

Compatible with:

- Core boards
- Core corner trim
- Core fascia boards
- Core skirting
- Starter clips
- Core/Rustic Quick clips (4mm)

### Core XL

180mm x 25mm x 3600mm

Compatible with:

- Core boards
- Core corner trim
- Core fascia boards
- Core skirting
- Starter clips
- Core/Rustic Quick clips

### Premium

140mm x 23mm x 3600mm

Compatible with:

- Premium boards
- Premium Bullnose boards
- Premium corner trim
- Premium fascia boards
- Premium skirting
- Starter clips
- Premium/Supreme Quick clips (4mm)

### Supreme

140mm x 20mm x 3600mm

Compatible with:

- Supreme boards
- Supreme Bullnose boards
- Supreme corner trim
- Supreme fascia boards
- Supreme skirting
- Starter clips
- Premium/Supreme Quick clips (4mm)

### Rustic

140mm x 23mm x 3600mm

Compatible with:

- Rustic boards
- Rustic fascia boards
- Starter clips
- Core/Rustic Quick clips (4mm)

## SUB-FRAME MATERIALS

Our sub-frame materials are compatible with all of our decking ranges. Choose your sub-frame materials based on your surface type and desired finished effect (**pg 15-35**).

### Joists

Composite joist  
40mm x 30mm x 3600mm

Eco lumber joist, available in:  
50mm x 50mm x 3100mm  
50mm x 100mm x 3400mm  
50mm x 150mm x 3400mm

Eco lumber post  
100mm x 100mm x 3400mm

---

### Pedestal supports

Joist pedestals, available in:  
A - 19mm - 30mm  
B - 29mm - 41mm  
C - 40mm - 64mm  
D - 63mm - 103mm  
E - 89mm - 195mm  
F - 176mm - 335mm

Joist cradle (5mm)

Slope corrector  
(12mm - 14mm)

---

### Deck tape

50mm  
82mm  
100mm

## ADDITIONAL FITTINGS

Depending on the range and installation methods you choose, you may need to purchase additional fittings. See **page 7** for our shopping list.

Throughout this guide, additional fittings are highlighted for easy identification.



Additional fittings may be required for this stage.

**BEFORE YOU GET  
STARTED**

# 1. Shopping list

You may need some or all of the following tools and fittings to complete your project. We recommend that you read through this guide before you start to determine what additional supplies you will need. All items can be found in your local hardware store.

- Circular saw**  
We recommend a 60 tooth tungsten carbide blade.
- Impact driver**  
Use 3mm and countersunk drill bits (or all-in-one smart bits).
- Power mitre saw**
- Jig saw**
- Tape measure**
- Carpentry square**
- Spirit level**
- Safety glasses and personal protection equipment (PPE)**
- Chalk line**
- Joist hangers**
- Countersunk screws**

## 2. Storage and handling

### 2.1 Storage

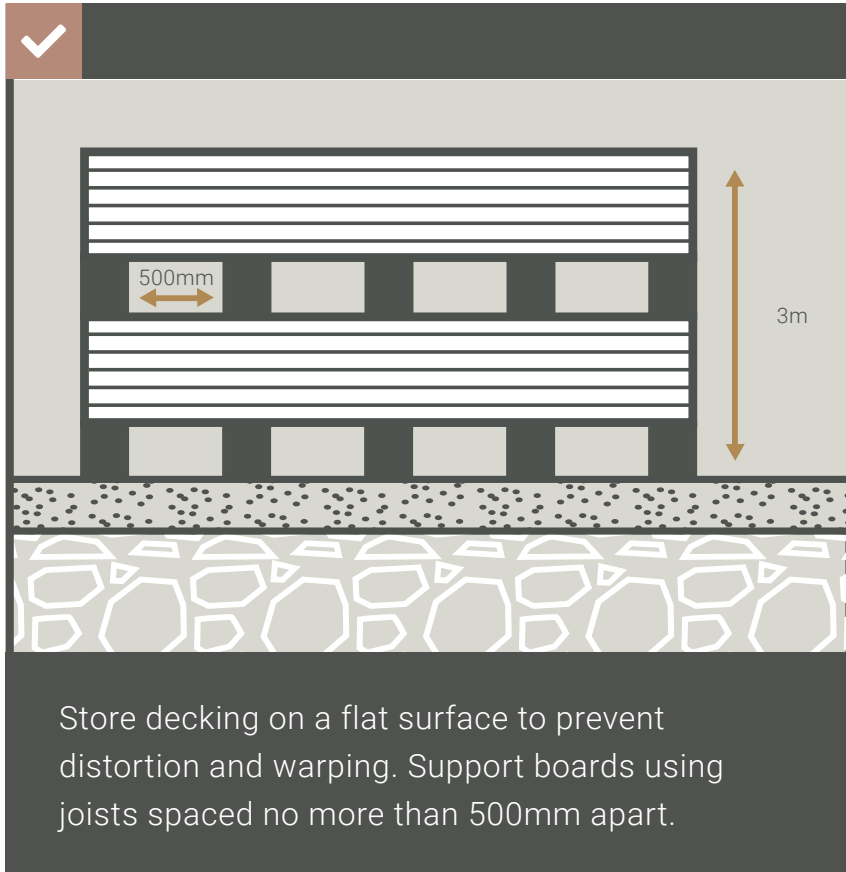

**NEVER** store boards directly on the ground.



**NEVER** stack boards higher than 3m.



**ALWAYS** store boards inside or keep covered.



**ALWAYS** let your decking boards acclimatise for at least **2 days** before beginning installation.

## 2.2 Handling

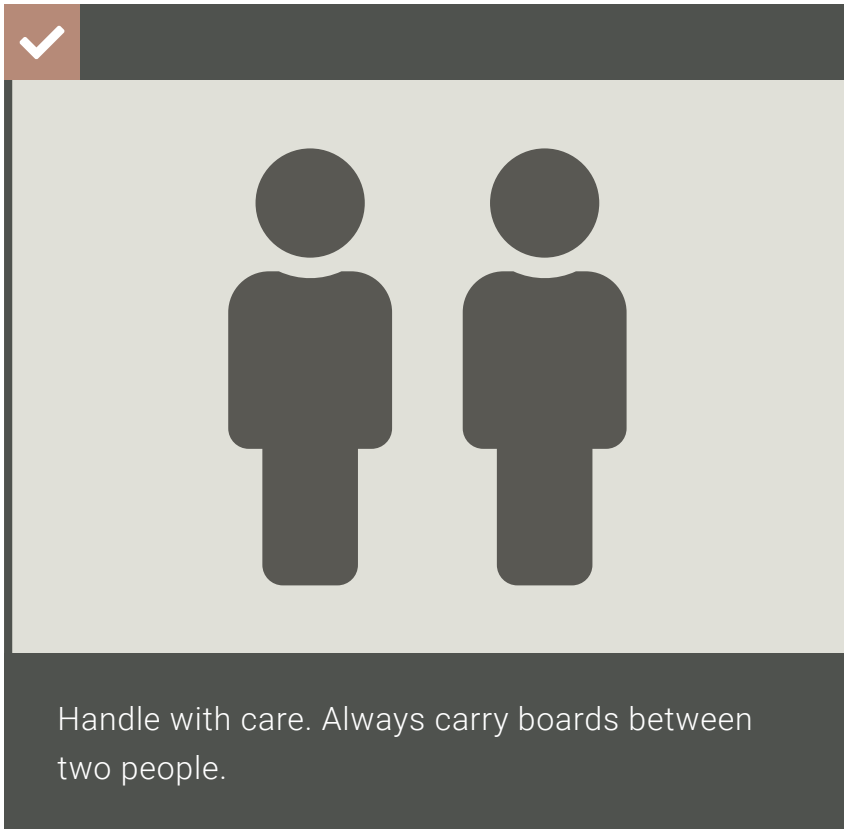

### HEAVY ITEMS



Place boards down carefully.  
**DO NOT** dump.



**DO NOT** slide or drag equipment across boards.



**DO NOT** slide boards against each other when handling.

# 3. Planning

## 3.1 Preparing the area

**Most decking structures require planning permission prior to installation. Check with your local authority.**

In addition, if your deck will be more than 1m above ground level, you must have your plans approved by a structural engineer.

Before you start, draw up your plans for approval.

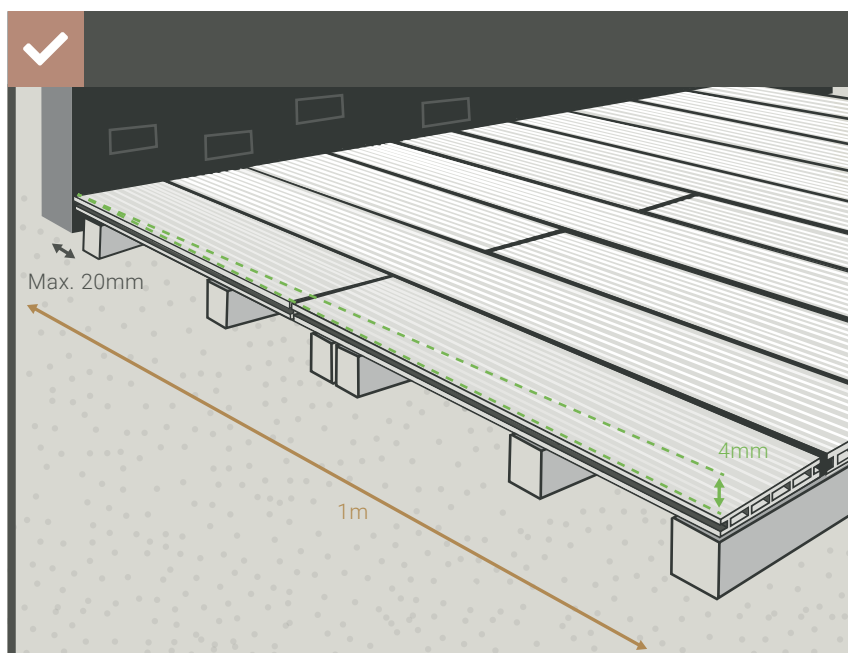

Your deck must be constructed on a stable, flat surface.

Incorporate a drainage slope of 4mm per metre to prevent water pooling.



The type of surface you are going to build your deck on will determine which method you use to construct your sub-frame (pg 15).



If constructing on a garden area, remove top layer of turf and lay scree/gravel to aid drainage. Cover area with a weed membrane.



Avoid installing decking near Low-E glass windows, as reflected UV rays can cause discolouration and bowing.



Your sub-frame must be **no less than 20mm** from other fixed objects, such as walls and fences.

## 3.2 Calculating materials

**It's important to measure your planned decking area carefully.**

Your decking boards **MUST** have a gap between them along all edges (**long and short**) to allow for expansion.

You need to factor this into your measurements when planning your decking area.

Premium and Supreme boards must have a **4mm** gap between ends of boards.

Core and Core XL boards must have a **6mm** gap between ends of boards.

Failure to allow room for your decking boards to expand will lead to warping and swelling.

1

Measure the width and length (in mm) of the area you plan to deck.

2

Plan which direction you want your decking boards to go. If you wish to lay your decking boards diagonally or add a picture frame border, see the relevant Advanced Technique section (**pg 46-51**).

Calculate how many boards you will need using the following rules and referring to the board measurement table below.

i. Divide area width by width of board plus clip spacing. Round up result.

**Area (w) ÷ board (w) + clip spacing = board rows**

ii. Divide area length by 3600mm (all our boards are the same length) plus expansion gap.

**Area (l) ÷ 3600 + gap = board lengths**

iii. Multiply board rows and board lengths to calculate boards required. Round up result.

**Board rows x board lengths = boards required**

iv. Add min. 5% (rounding up) to allow for wastage caused by cutting.



Add at least **5%** to the total material required to allow for wastage caused by cutting.



Always round **UP** when calculating the amount of material you need.



For multiple decking areas, follow these steps for each area and then add the results together.



For more complex shapes, see our online guide.



### EXAMPLE

If your area is 3m (w) x 8m (l) (3000mm x 8000mm) and you are using Core boards:

$$3000 \div (146 + 4 = 150) = \mathbf{20} \text{ board rows}^*$$

$$8000 \div (3600 + 6 = 3606) = \mathbf{2.2} \text{ board lengths}$$

$$20 \times 2.2 = \mathbf{44} \text{ total material}^*$$

$$+ 5\% = \mathbf{47} \text{ boards total}^*$$

\* Rounding result **UP** to nearest whole number

Board measurement table

Range	Width (mm)	Height (mm)	Length (mm)	Expansion gap (mm)	Clip spacing (mm)
Core	146	25	3600	6	4
			5000		
Core XL	180	25	3600	6	4
Premium	140	23	3600	4	4
Supreme	140	20	3600	4	4
Rustic	140	25	3600	6	4

# LAYING YOUR DECKING

# 4. Sub-frame installation

## 4.1 About the sub-frame

**Before you can install your decking boards, you MUST create a sub-frame.**

Your sub-frame can be built using composite joists or eco lumber joists with posts. See **page 5** for the full range of materials available. You can also use treated timber.

If you are constructing your deck on a **SOLID FLAT** surface that has not been raised – such as concrete – use composite joists.

If you are constructing your deck on a **SOFT UNEVEN** surface, or a surface that has been raised, use eco lumber joists with posts.

You can also use pedestal supports (**pg 24-34**) with your support frame to adjust your decking to the correct height, and slope correctors (**pg 35**) to ensure a flat surface. See **page 5** for the full range of materials available.



Your sub-frame must be **no less than 20mm** from other fixed objects, such as walls and fences.



If you are using timber to create your sub-frame, we recommend using our deck tape (**pg 23**) to protect it.

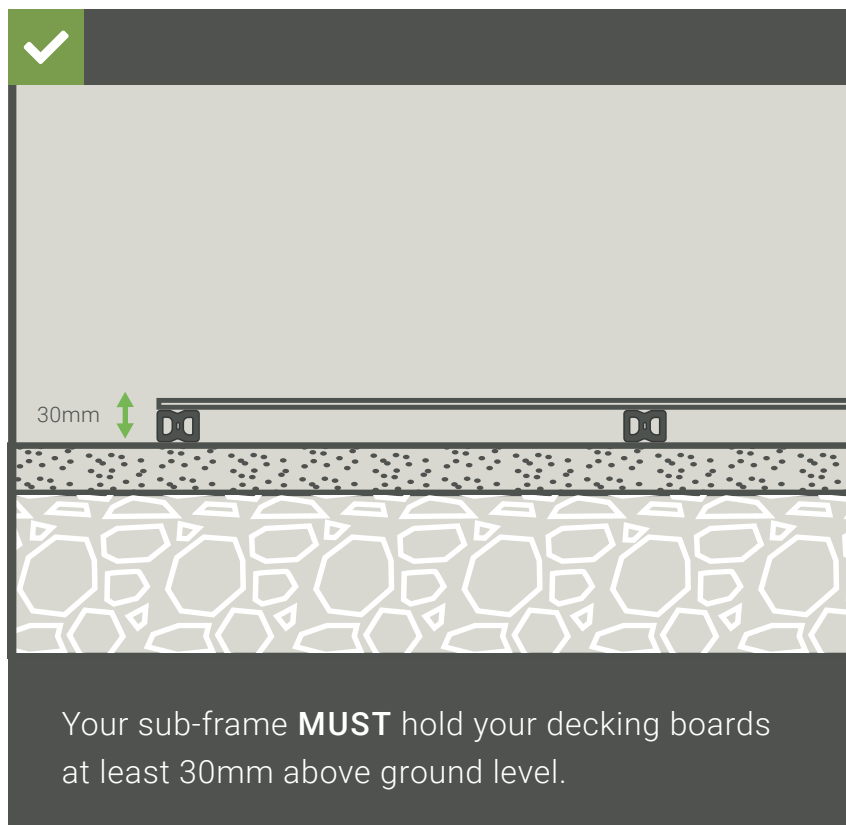

## 4.2 Building a sub-frame on a flat concrete surface

1

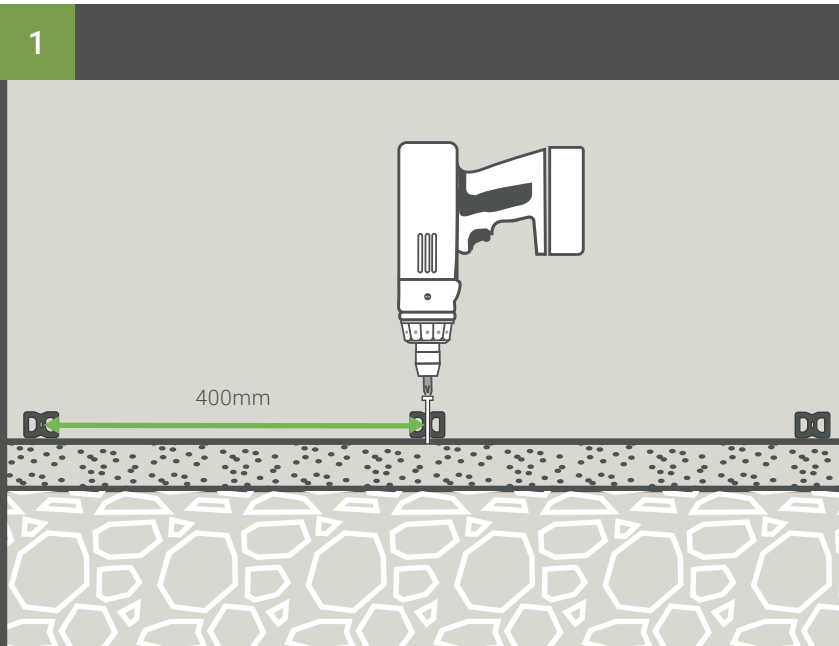

Place composite joists directly on your flat surface.

For residential projects, joists must be placed no more than **400mm** apart.

Screw joists into the ground as you build the frame using our joist screws.



**ALWAYS** measure joists from centre to centre.



For commercial projects, joists must be placed no more than **300mm** apart.

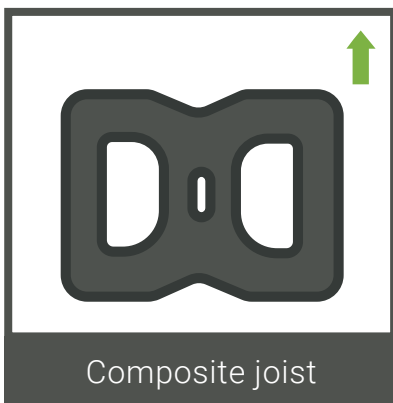

Composite joist

## 4.2 Building a sub-frame on a flat concrete surface (continued)

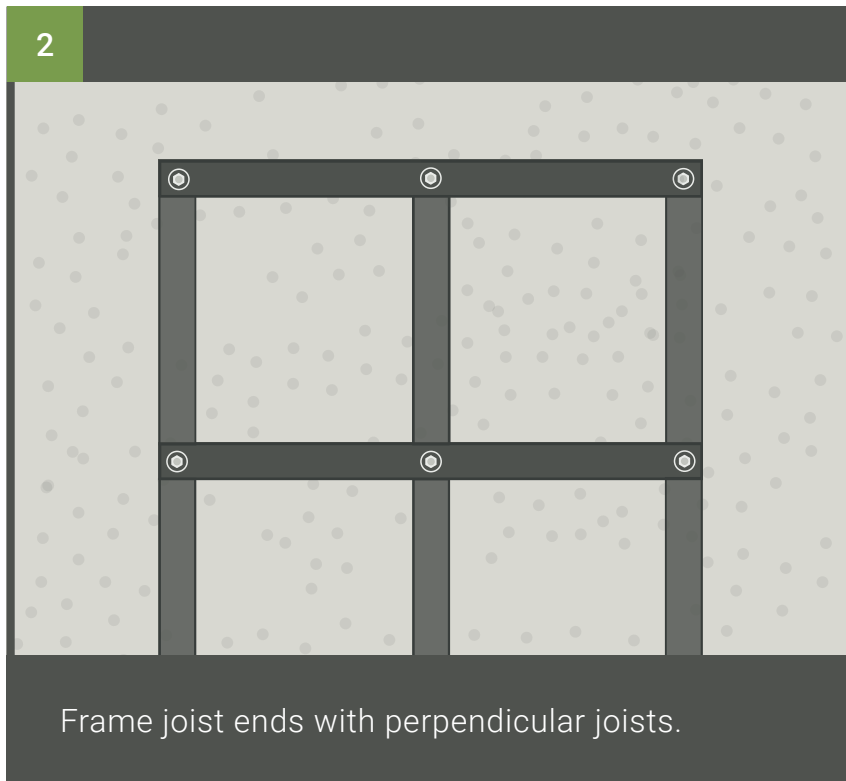

The joists that run around the outside of your sub-frame are referred to in this guide as **perimeter joists**.

### 4.3 Building a sub-frame on a soft uneven surface

**1**

500mm

x mm

Posts are needed to support the sub-frame. They should be sunk into the ground 500mm deep (or 1/3 of the post's height). Use concrete or postcrete to secure them.



When installing on soft ground, posts are required to support the subframe above ground.



See the table below to determine the maximum distance between posts.

#### Recommended max. distance between posts

Joist material	Joist dimensions	Max. distance between posts	Posts per 5m
Eco lumber	150mm x 50mm	1500mm	3-4
Eco lumber	100mm x 50mm	750mm	6-7
Eco lumber	50mm x 50mm	500mm	10
Eco lumber posts	100mm x 100mm	n/a	n/a



There are multiple factors that can affect the strength of your sub-frame, including the size of your joists and the material used.

Note that the distances stated left are **guidelines only**.

## 4.3 Building a sub-frame on a soft uneven surface (continued)

2

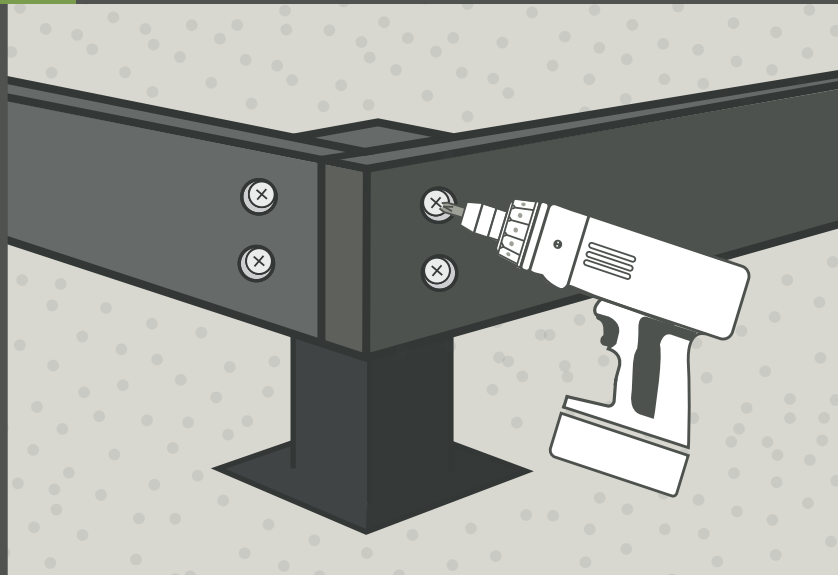

Once posts are set, attach the perimeter joists.

- (i) Drill pilot holes through joist and post.
- (ii) Countersink holes to ensure screw heads sit below surface.
- (iii) Screw into place.

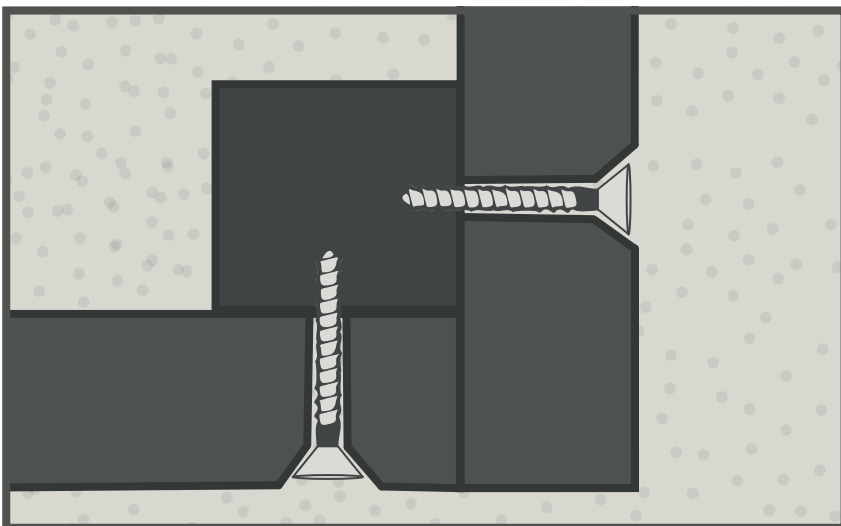

The joists that run around the outside of your sub-frame are referred to in this guide as **perimeter joists**.



**ALWAYS** measure joists from centre to centre.



Upsize the pilot holes in the joists by **2mm** to allow for expansion.

### 4.3 Building a sub-frame on a soft uneven surface (continued)

3

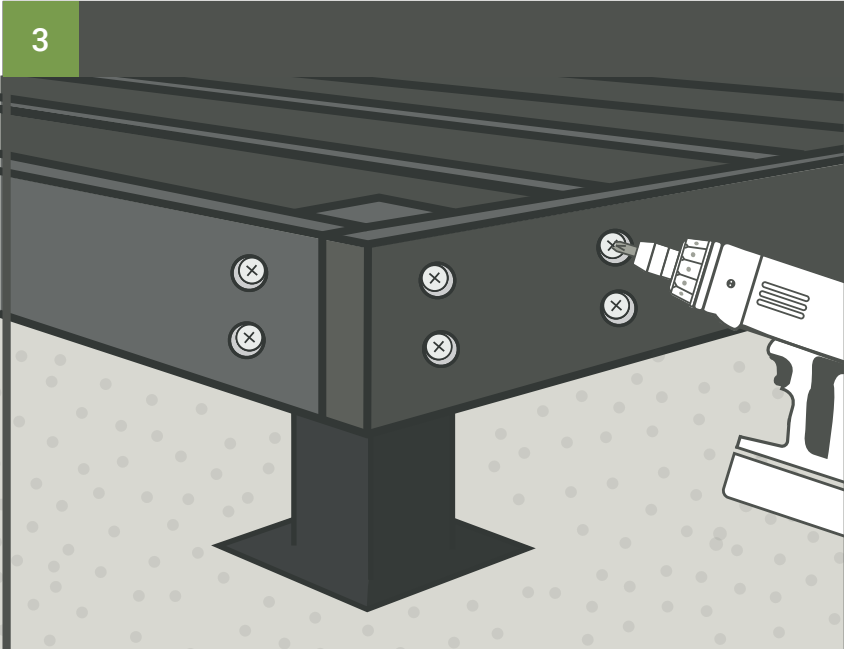

Fix the interior joists (and noggins) in place using the same method.

For residential projects, joists must be placed no more than **400mm** apart.

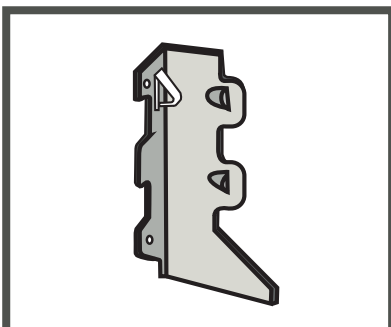

Joist hanger

Alternatively, you can use joist hangers to hold interior joists to perimeter joists. This is ideal if you have limited space.



Strengthen your sub-frame with additional supports (noggins).



**ALWAYS** measure joists from centre to centre.



For commercial projects, joists must be placed no more than **300mm** apart.



Oversize the pilot holes in the joists by **2mm** to allow for expansion.



Additional fittings may be required for this stage.

#### 4.4 Fitting joists end-to-end (butt-jointing)

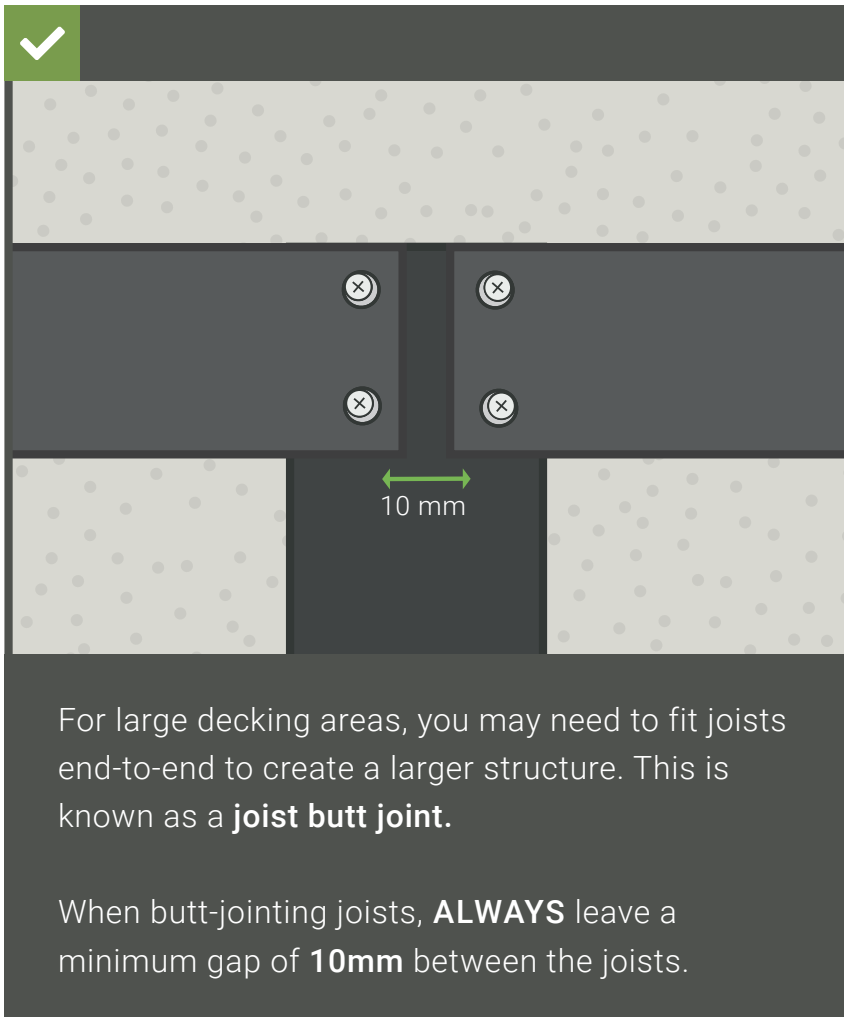

Joist butt joints **MUST** have a min. **10mm** gap between them to allow for expansion and prevent water pooling.

## 4.5 Sister joists

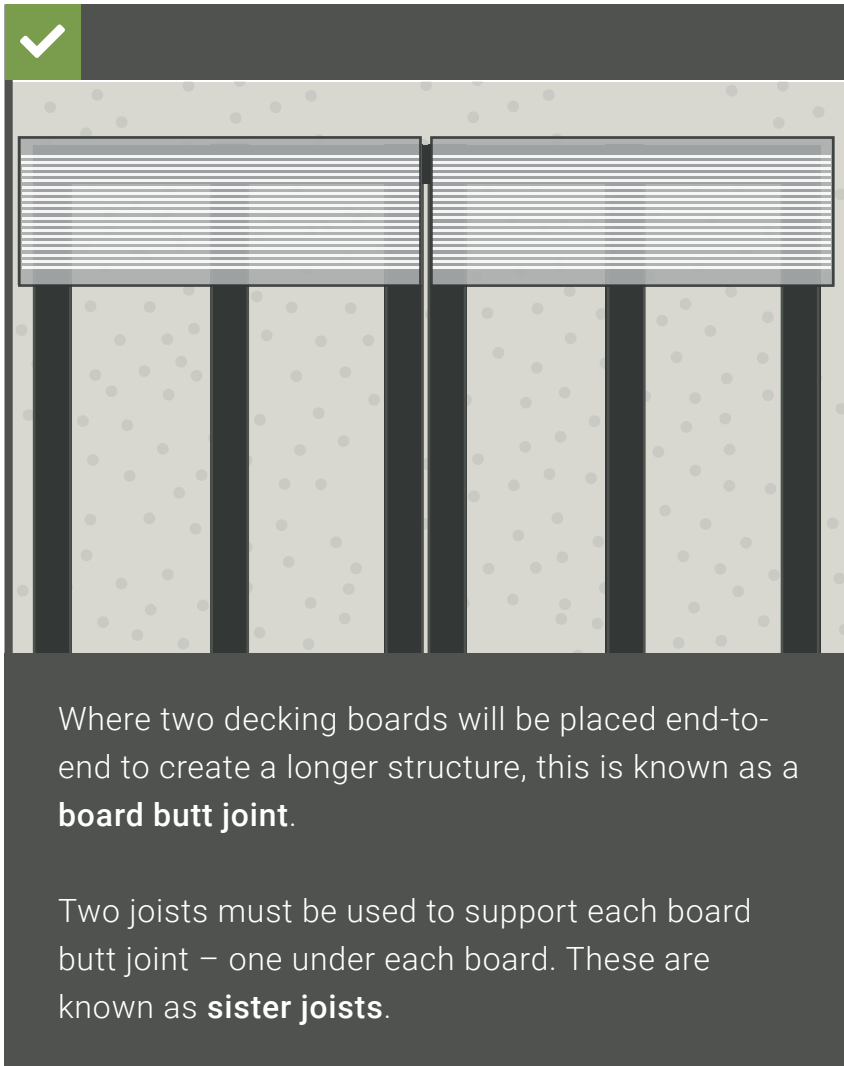

Sister joists **MUST** have a **5mm** gap between them to allow for expansion and to prevent water pooling..



Premium and Supreme boards **MUST** have a **4mm** gap between butt-jointed boards.

Core, Core XL and Rustic boards **MUST** have a **6mm** gap between butt-jointed boards.

## 4.6 Using deck tape

**Completely protect and seal your new or existing deck frame or timber structure with deck tape.**

Deck tape is designed to be applied along the top of the timber joists, ledgers and around posts.

It protects decking frames from water/moisture rot and frame weathering. This tape also protects decking frames where they are exposed between decking boards.

- Water and weather resistant (-40°C to +93°C)
- Completely UV stable
- Permanent adhesive bond for 50 years
- Available in three sizes (50mm, 82mm or 100mm)



Unprotected timber can rot and swell with moisture exposure. Our deck tape protects timber structures by creating a completely waterproof seal.

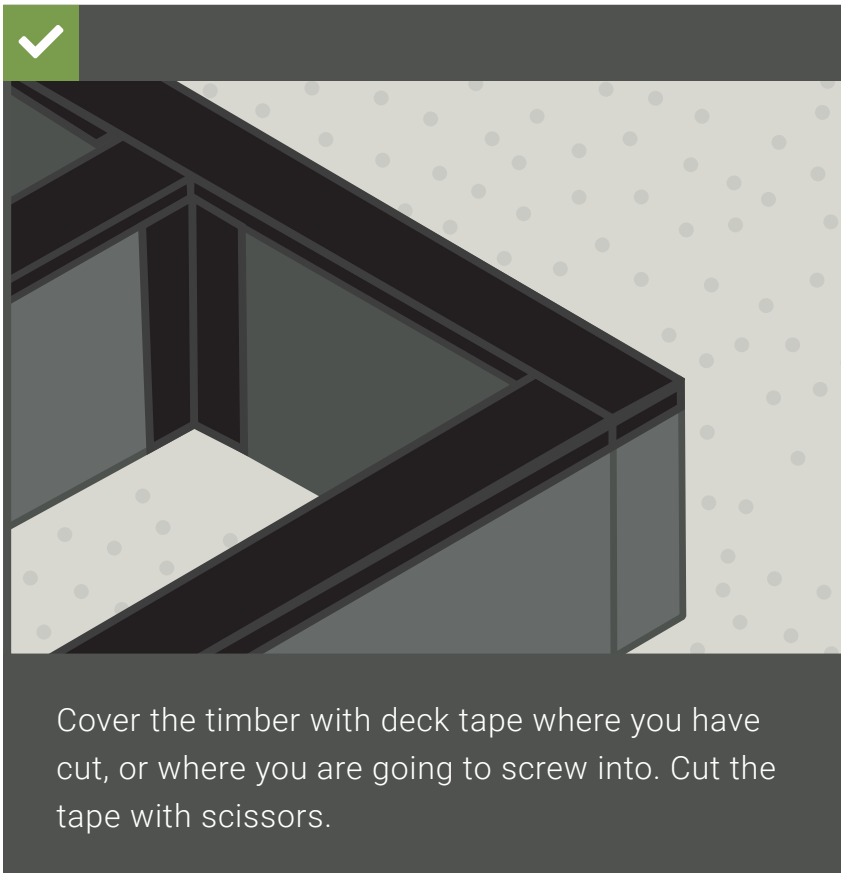

## 4.7 Using support pedestals

On a solid, flat foundation such as a patio, concrete, roof terrace or even compacted hardcore, the sub-frame of your decking can be easily raised using our adjustable support pedestals.

Simply position beneath your sub-frame and adjust to the desired height by rotating the pedestal base.

If using pedestals, follow these steps **BEFORE** you begin building your sub-frame.

1

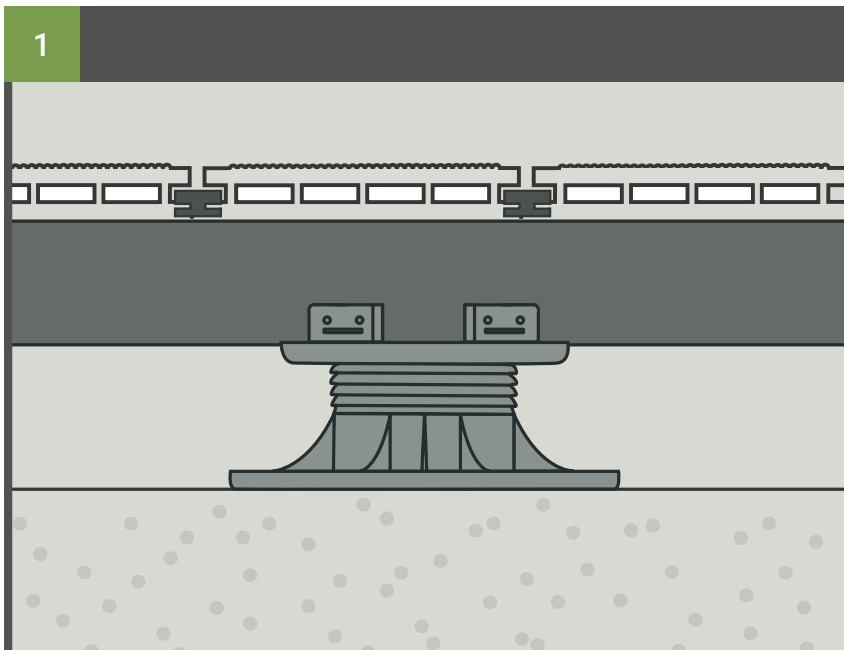

Determine which type of pedestal you need. Our pedestals come in 6 different heights:

A - 19mm-30mm	D - 63mm-103mm
B - 29mm-41mm	E - 89mm- 185mm
C - 40mm-64mm	F - 176mm-335mm



Take into account the height of your joists and the thickness of your decking boards when determining which pedestal type to choose - see opposite.



Note that the pedestal cradle used to fix joists to pedestals adds **5mm** to the height of a pedestal.

## 4.7 Using support pedestals (continued)



### EXAMPLE

You're using 150mm x 50mm eco lumber to build your sub-frame and Core boards for your decking.

You want to raise your deck by around 260mm.

Your eco lumber sub-frame is 150mm high and Core boards are 25mm thick, giving your decking a height profile of 175mm.

$$260\text{mm} - 175\text{mm} = 85\text{mm}$$

The best pedestal to choose will be D, which is adjustable from 63mm to 103mm.

## 4.7 Using support pedestals (continued)

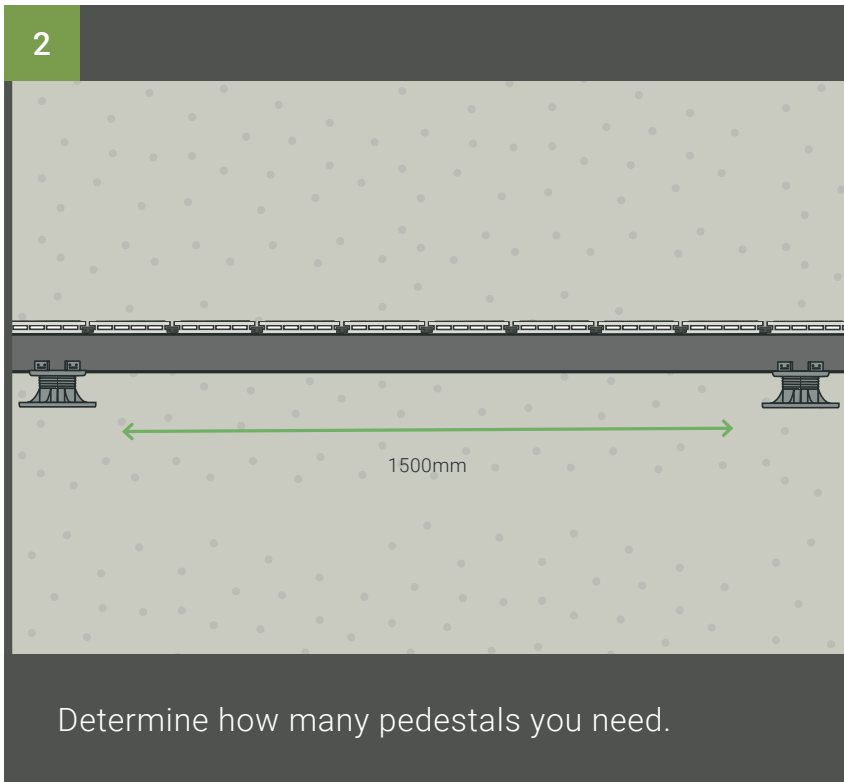

The number of pedestals you will need depends on the size and material used for your sub-frame - see table below.

### Recommended max. distance between pedestals

Joist material	Joist dimensions	Max. distance between peds	Pedestals per 5m
Eco lumber	150mm x 50mm	1500mm	3-4
Eco lumber	100mm x 50mm	750mm	6-7
Eco lumber	50mm x 50mm	500mm	10
Comp. joists	30mm x 40mm	300mm	16-17



There are multiple factors that can affect the strength of your sub-frame, including the size of your joists and the material used.

Note that the distances stated left are **guidelines only**.

## 4.7 Using support pedestals (continued)

Preparing a flat and solid ground surface

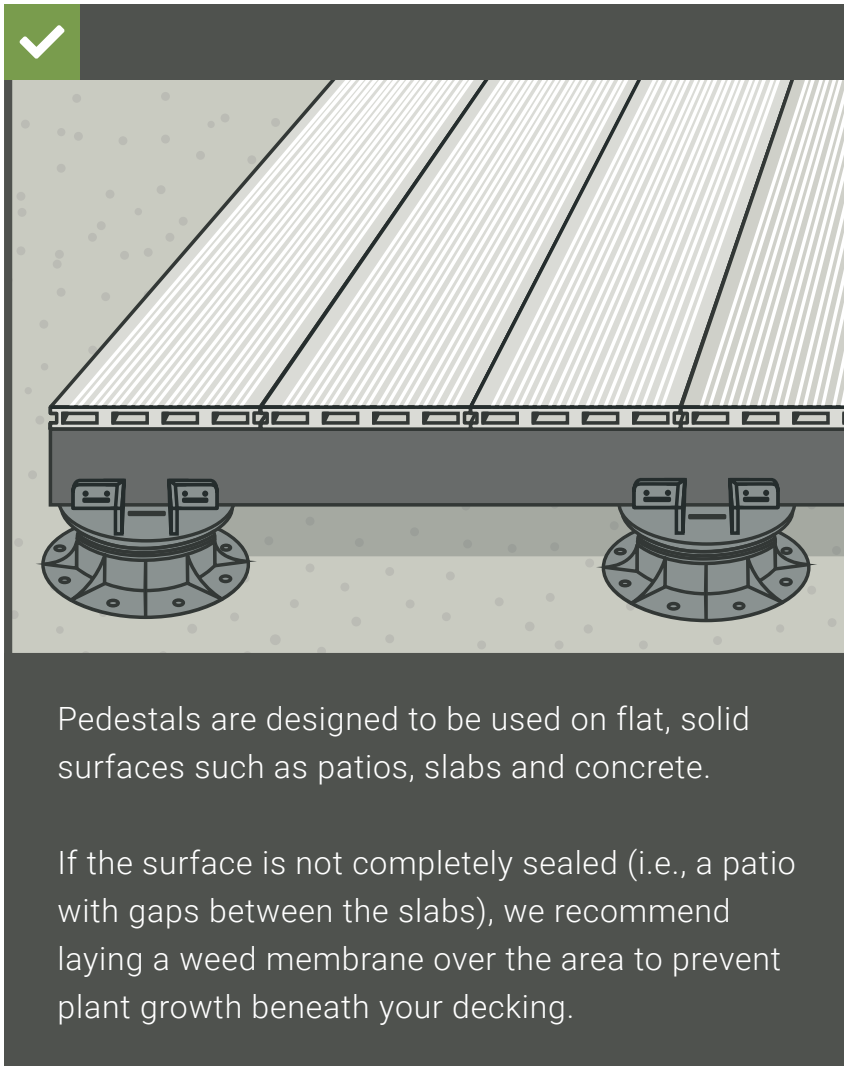

If the ground surface is not flat and stable, deformation of the decking surface may occur.



Incorporate a drainage slope of 4mm per metre to prevent water pooling.

## 4.7 Using support pedestals (continued)

### Preparing a soft or uneven ground surface

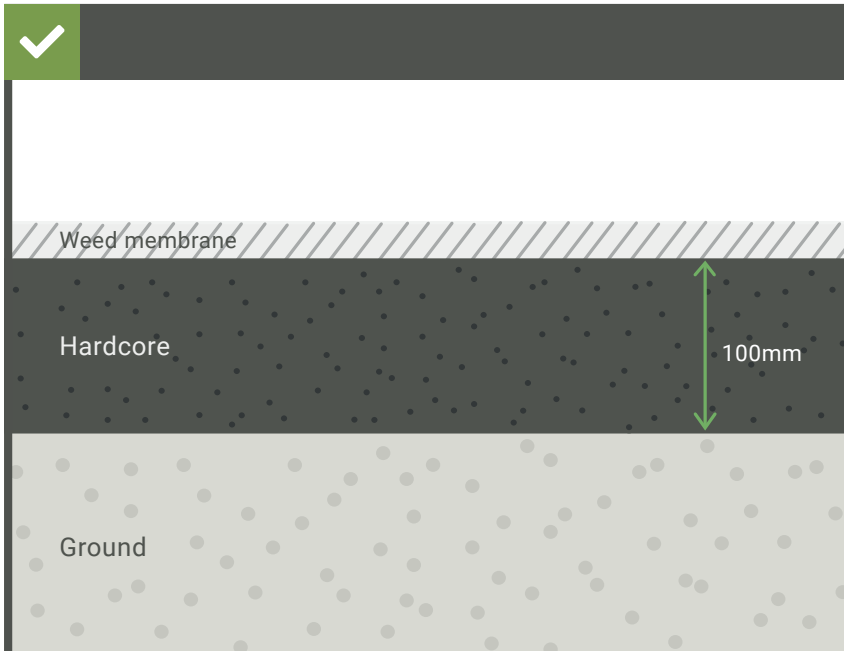

If your ground surface is soft or uneven, you will need to prepare it before you can place your pedestals.

Excavate at least 100mm of ground. In some situations more may be required. Infill with type 1.

Thoroughly compact the type 1 with a compacting plate to create a firm, level surface to ensure no dipping over time.

Cover the area with weed membrane to prevent plant growth beneath the decking.



If the ground surface is not flat and stable, deformation of the decking surface may occur.



Incorporate a drainage slope of 4mm per metre to prevent water pooling.



We recommend going over the area with the compacting plate at least twice.

## 4.7 Using support pedestals (continued)

### Installing and adjusting the decking pedestals

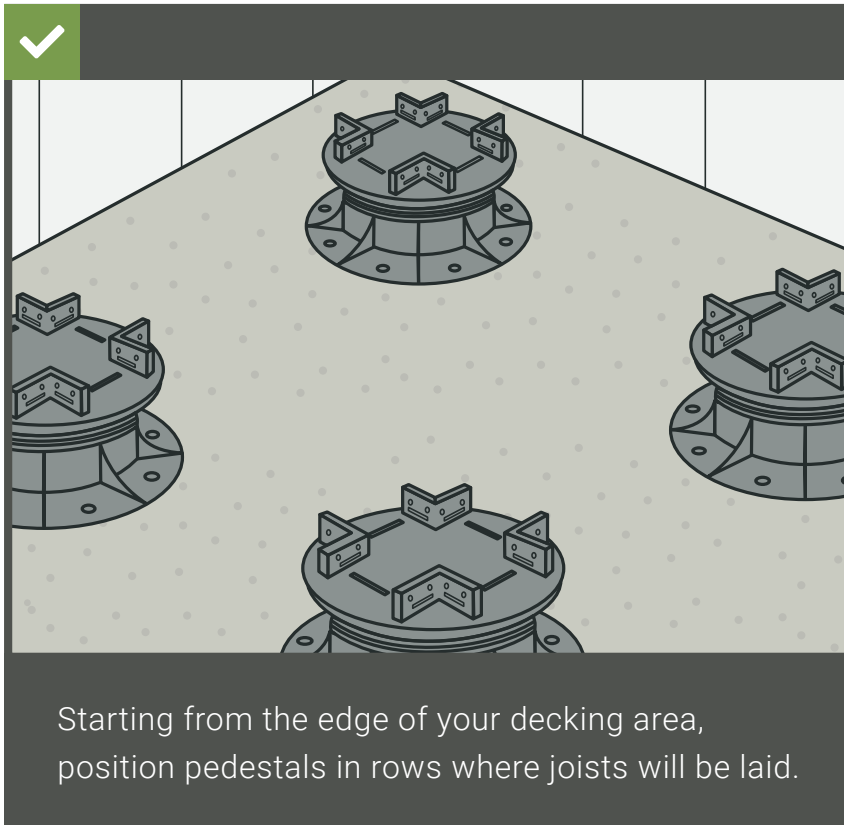

Ensure you do not exceed the recommended max. distance between pedestals (pg 26).

## 4.7 Using support pedestals (continued)

### Installing and adjusting the decking pedestals (continued)

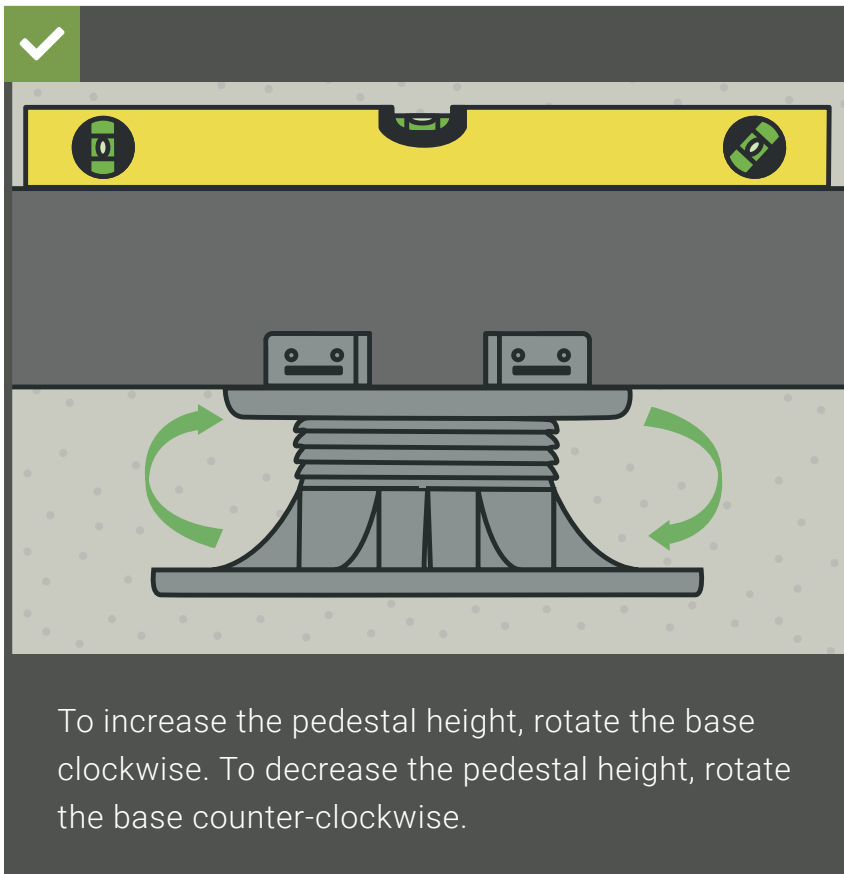

Ensure all pedestals are adjusted to the correct height before you begin building the sub-frame.



Use a spirit level to ensure joists are the correct level before fixing to pedestals.

## 4.7 Using support pedestals (continued)

### Laying joists on pedestals

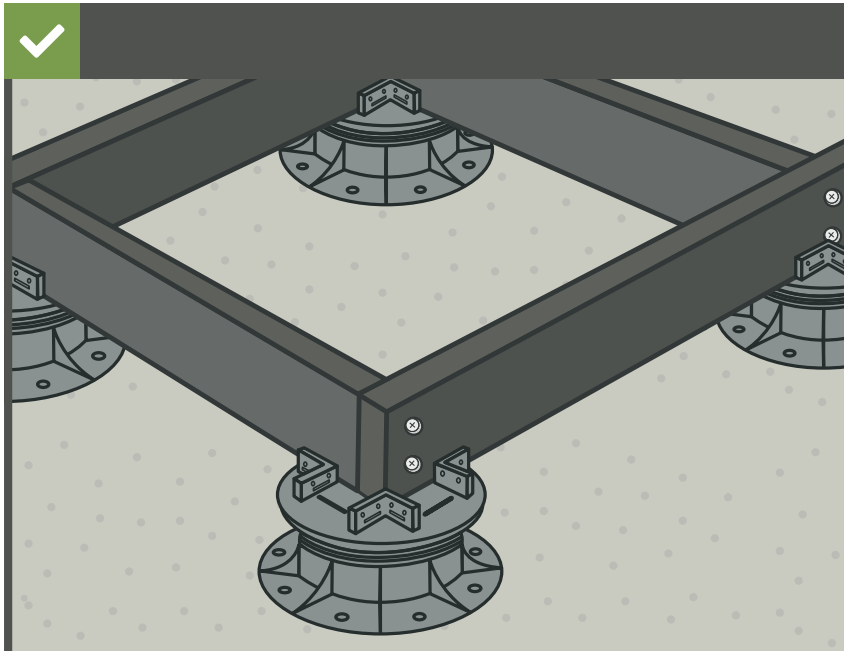

Starting from the edge of your decking area, position the joists on top of the pedestals.

For residential projects, joists must be placed no more than **400mm** apart.

Ensure that the joists and noggins are fully supported by the pedestals. You may need to adjust the position of the pedestals as you work.



Strengthen your sub-frame with additional supports (noggins).



**ALWAYS** measure joists from centre to centre.



For commercial projects, joists must be placed no more than **300mm** apart.



Attach your joists together as normal (**pg 15-22**).

## 4.7 Using support pedestals (continued)

### Laying joists on pedestals (continued)

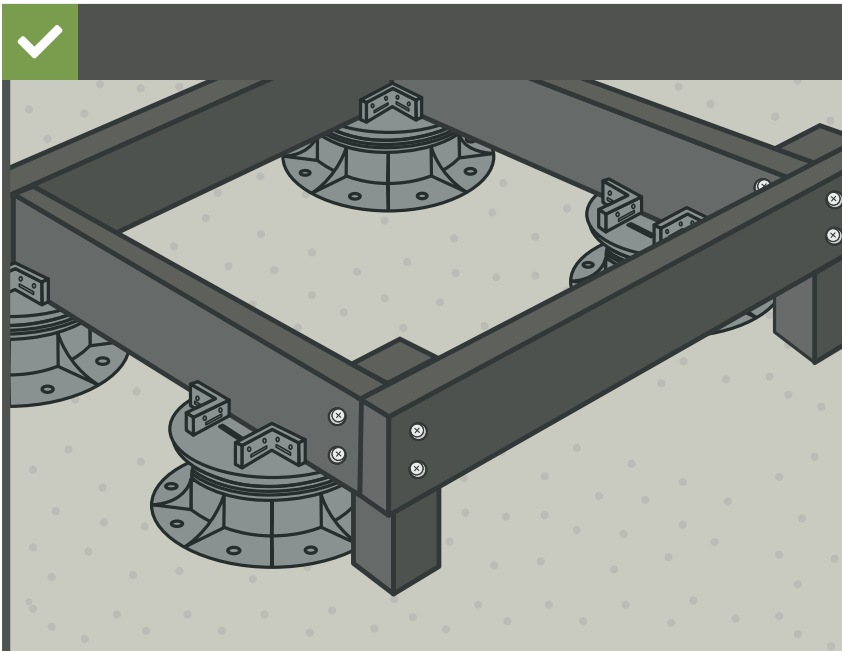

Note that if you wish to install finishing boards **(pg 52-54)** around your decking, you will need to adjust the position of the outer pedestals so that they don't protrude beyond the decking edge.

Use joist off-cuts to support the perimeter joists.



Attach your joists together as normal **(pg 15-22)**.

## 4.7 Using support pedestals (continued)

### Laying joists on pedestals (continued)

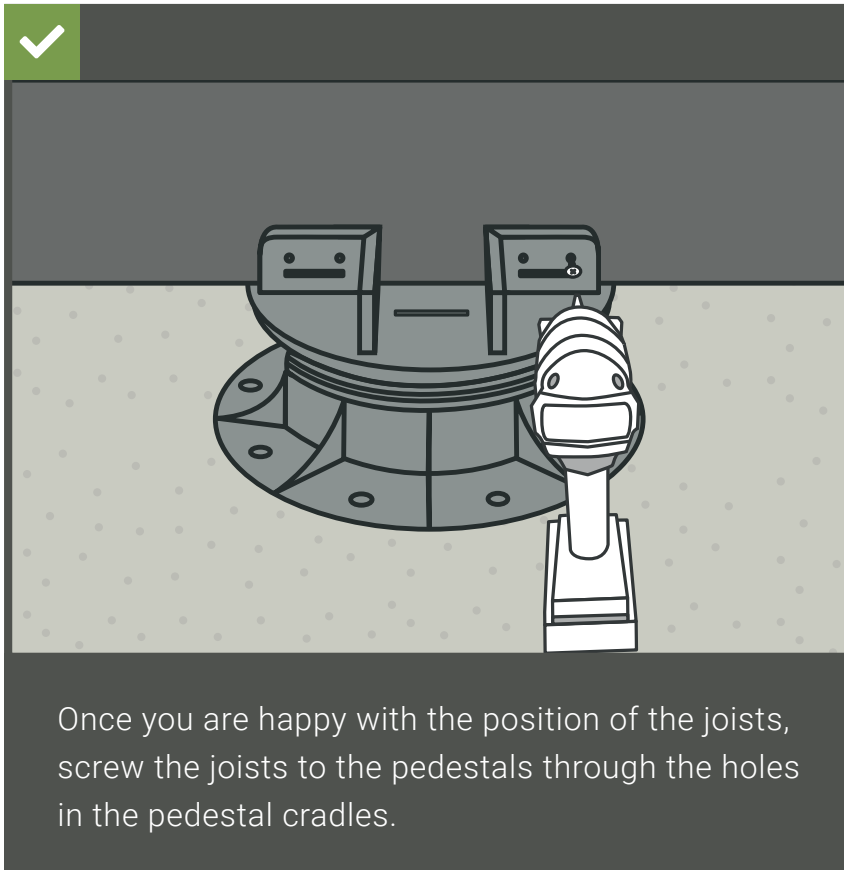

In most cases, the weight of the decking is sufficient to hold the pedestals securely in place.

If the ground surface is suitable, you can screw pedestals to the ground for further stability.

## 4.7 Using support pedestals (continued)

Sister joists (pg 22) and  
end-to-end joists

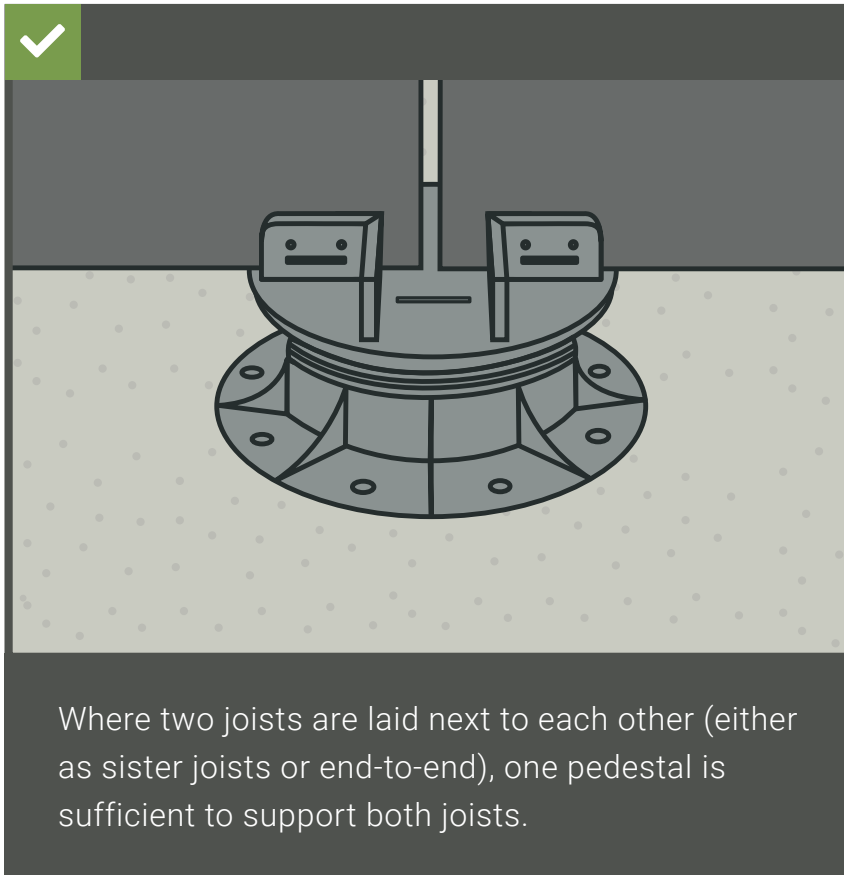

Joist butt joints **MUST** have a min. **10mm** gap between them to allow for expansion and prevent water pooling.



Sister joists **MUST** have a **5mm** gap between them to allow for expansion and to prevent water pooling.

## 4.8 Using slope correctors

Our decking pedestals can be used with slope correctors.

If your existing ground surface is completely level, you may want to incorporate a gradient to avoid water pooling.

Alternatively, if your ground surface has a severe gradient, you can use slope correctors to reduce the gradient of your decking.

Slope correctors are adjustable from 1° to 5°.

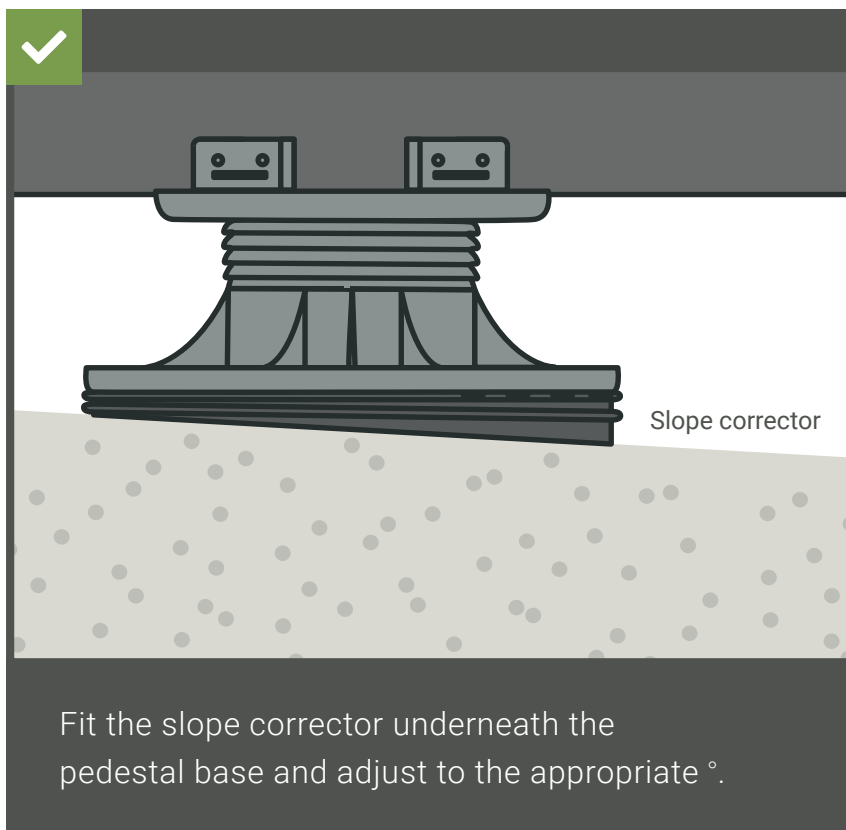

Note that a slope corrector adds **8mm - 18mm** to the height of a pedestal, depending on the angle.



Use the numbered tabs on the slope corrector to achieve the correct angle. For example, 3 = 3°.

# 5. Decking installation

## 5.1 Fitting the first board

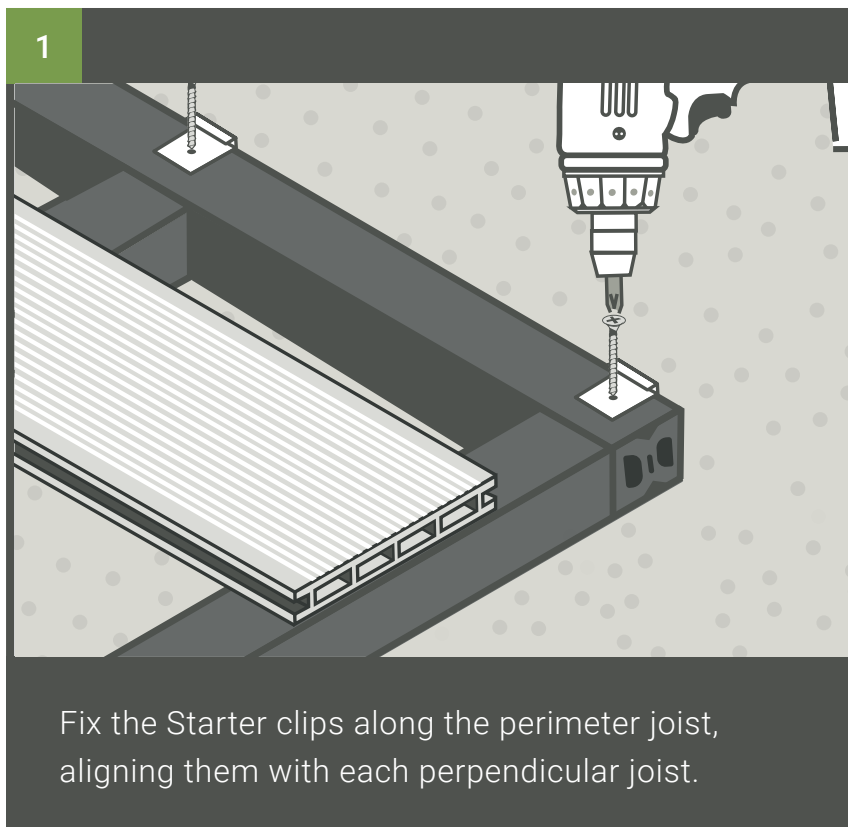

**PREMIUM /  
SUPREME ONLY**  
If using Bullnose  
edging boards,  
install these first  
(pg 44-45).

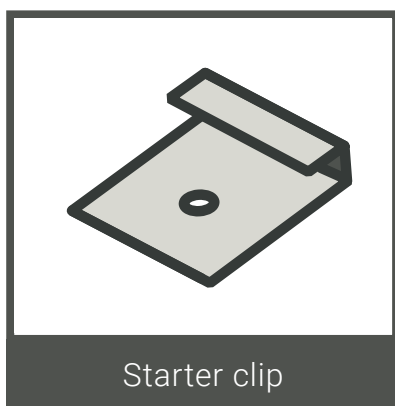

## 5.1 Fitting the first board (continued)

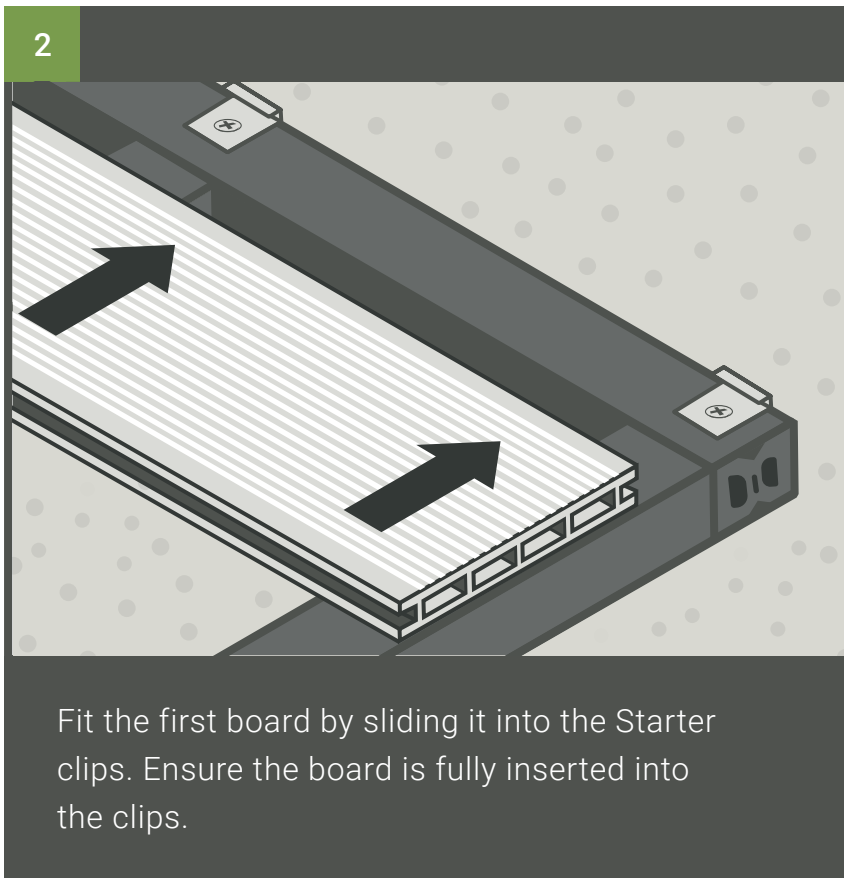

## 5.2 Fitting subsequent boards

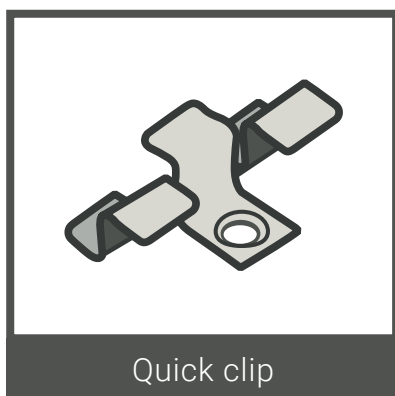
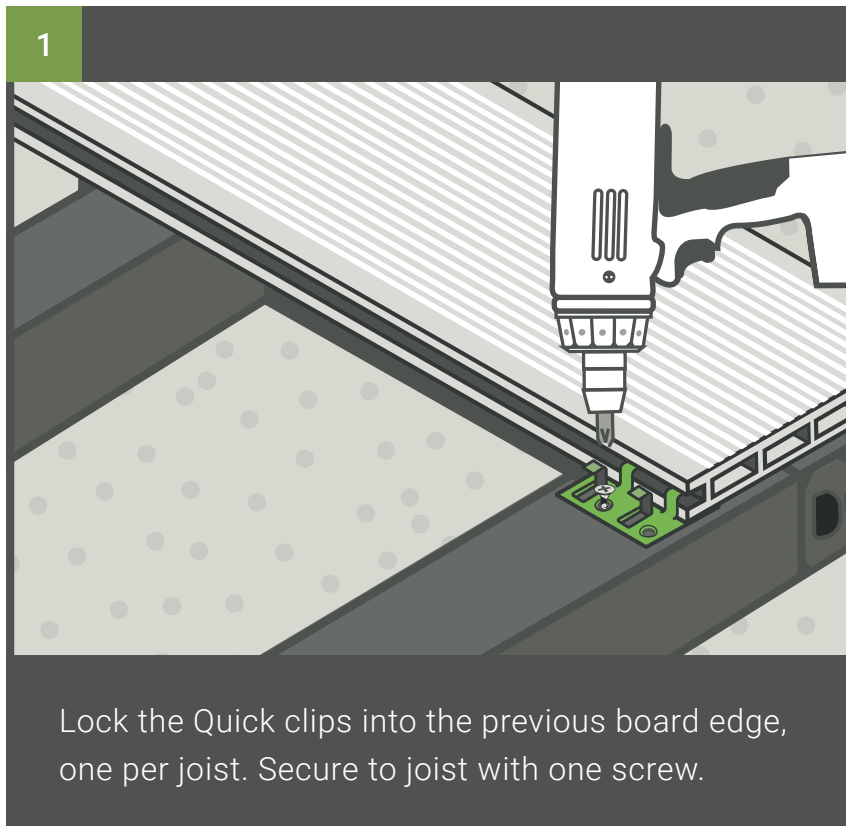

The Quick clips maintain a consistent gap of **4mm** between board lengths.



Quick clips have more than one hole to give you more options when fitting. **You only need to use ONE screw per clip.**



The screw will require T15 torx head.

## 5.2 Fitting subsequent boards (continued)

2

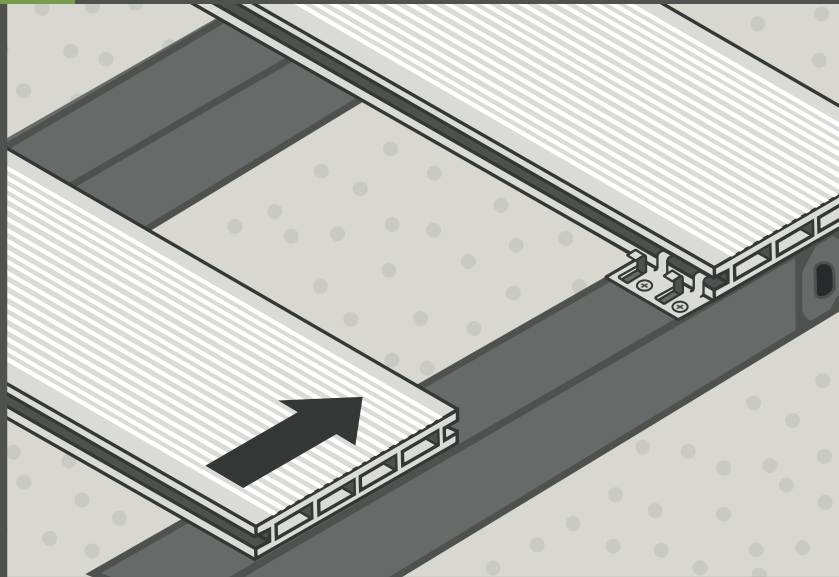

Fit the next board by sliding it into the Quick clips and clipping into place.



### DESIGN TIP

Mix boards to create a natural range of light and dark tones.

Ensure that the grain on the boards is always running in the same direction.

## 5.3 Fitting the end board

### METHOD 1

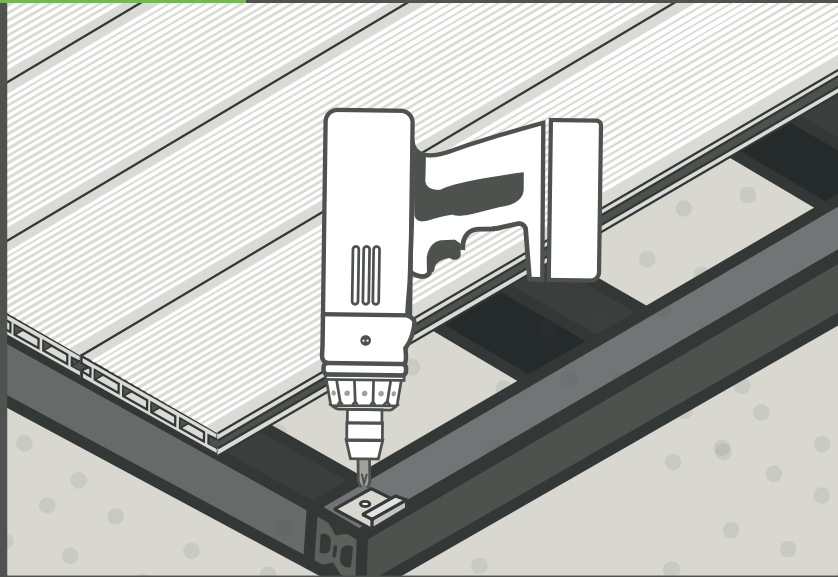

- i. Before fitting the end board, measure where the Starter clips should be on the perimeter joist and secure the first one in place.



Note that for this method you **MUST** have a board length's worth of space on one side of your deck area.

If you don't have space, use **method 2** (pg 42).



**DO NOT** fix all Starter clips at once. Fix gradually as you go along.

### 5.3 Fitting the end board (continued)

#### METHOD 1

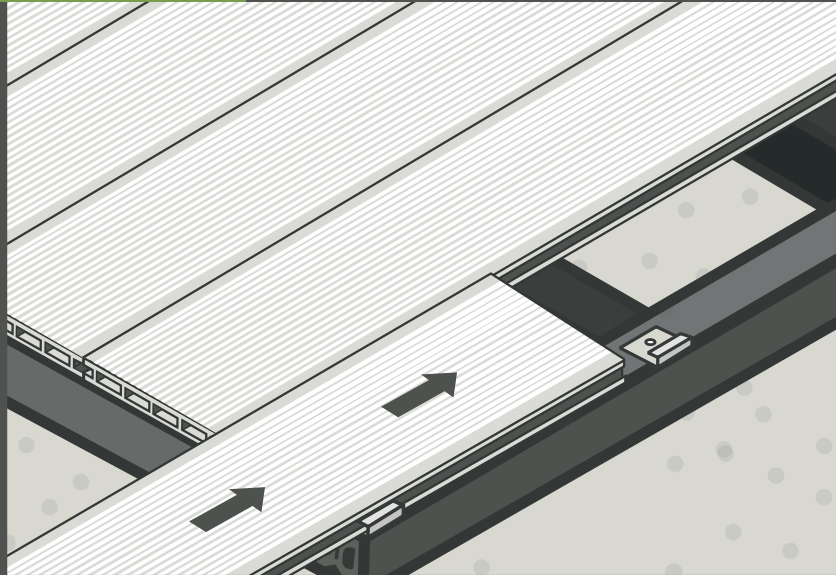

ii. Slide the end board into the clips from one end.

### 5.3 Fitting the end board (continued)

#### METHOD 2

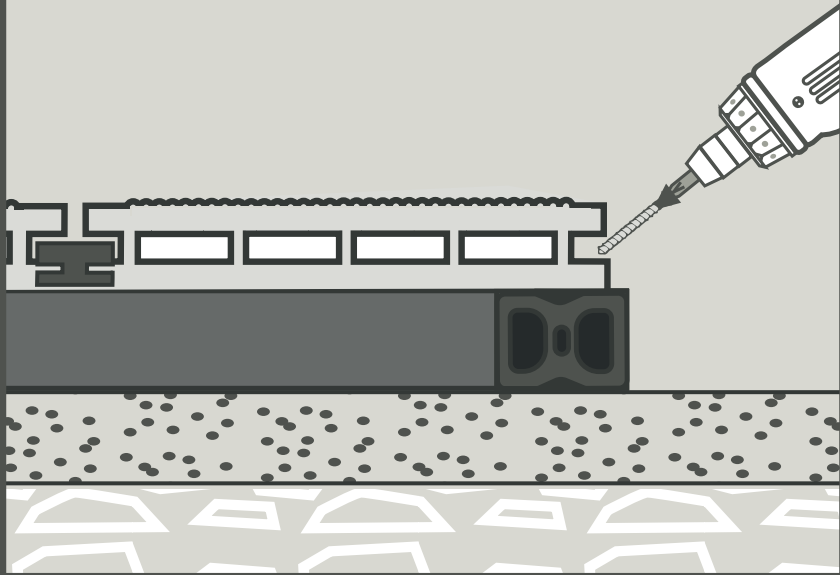

With all boards in place, screw through the bottom edge of the end board at an angle, securing it to the perimeter joist at 300mm intervals.



**DO NOT** overdrive screws as this may cause material to split.



When fitting the end board, ensure there is no more than **20mm** of the board overhanging the perimeter joist.



Pre-drill pilot holes through the end board to avoid splitting the material.



Additional fittings may be required for this stage.

## 5.4 Fitting boards end-to-end (butt-jointing)

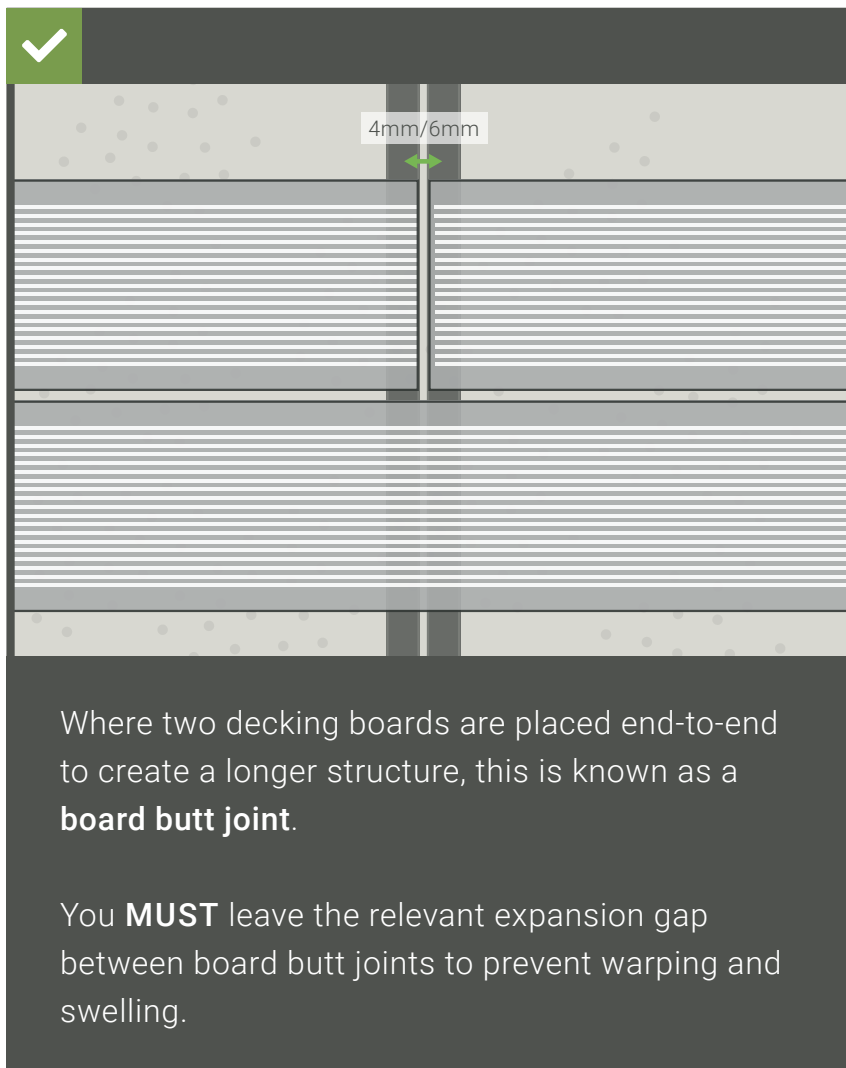

Where two decking boards are placed end-to-end to create a longer structure, this is known as a **board butt joint**.

You **MUST** leave the relevant expansion gap between board butt joints to prevent warping and swelling.



Premium and Supreme boards **MUST** have a **4mm** gap between butt-jointed boards.

Core, Core XL and Rustic boards **MUST** have a **6mm** gap between butt-jointed boards.



Board butt joints **MUST** be supported by **sister joists**.

## PREMIUM / SUPREME ONLY BULLNOSE BOARDS

Part of the **Premium** and **Supreme** ranges, Bullnose edge boards can be used to create a flush finish for decking

edges and steps. Bullnose edge boards **MUST** be installed before the rest of the decking boards.

**For Bullnose boards that run PARALLEL to the decking boards**

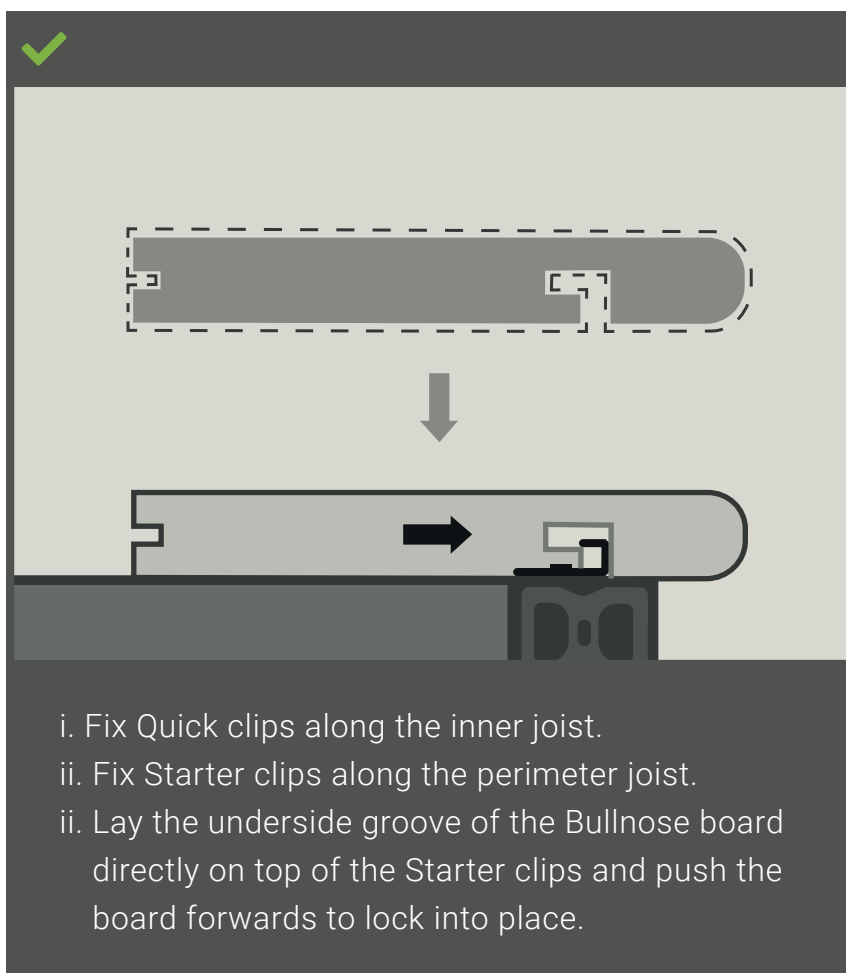

## PREMIUM / SUPREME ONLY BULLNOSE BOARDS

For Bullnose boards that run  
PERPENDICULAR to the  
decking boards

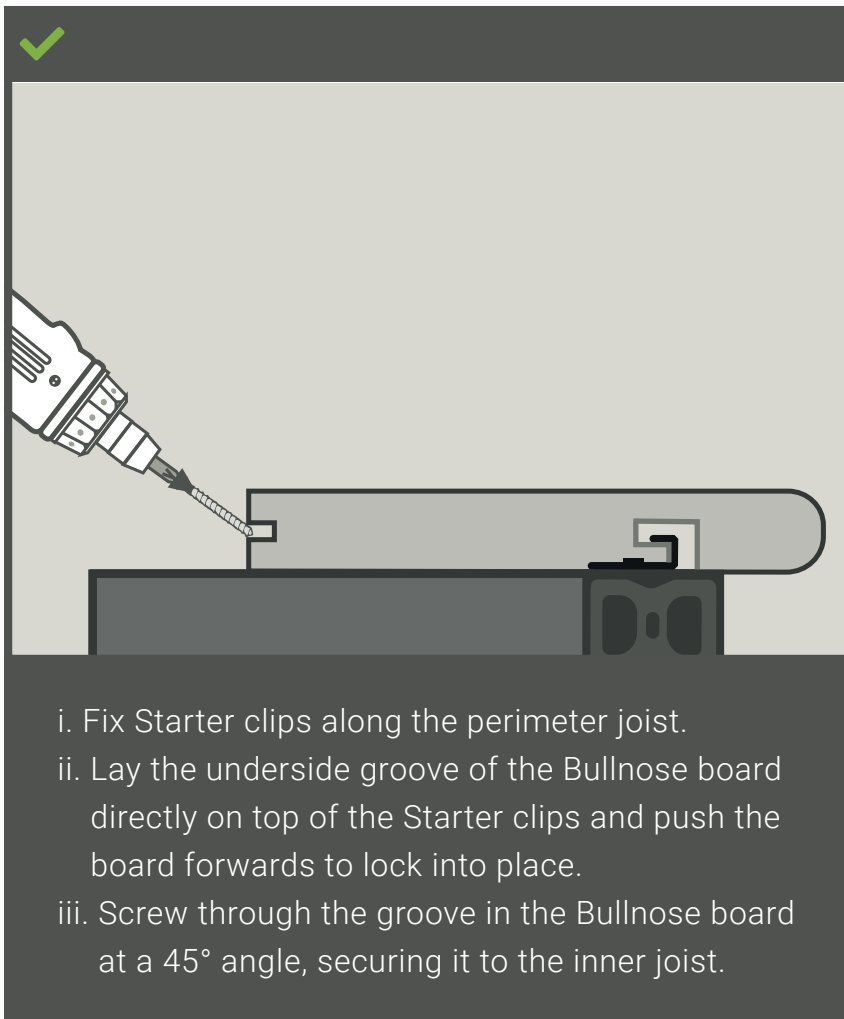

You will need to lay extra joists around your sub-frame to support the Bullnose boards.



Pre-drill pilot holes through the Bullnose board to avoid splitting the material.



Do not overdrive the screws as this may cause the material to split.



Additional fittings may be required for this stage.

## ADVANCED TECHNIQUE DIAGONAL BOARDS

1

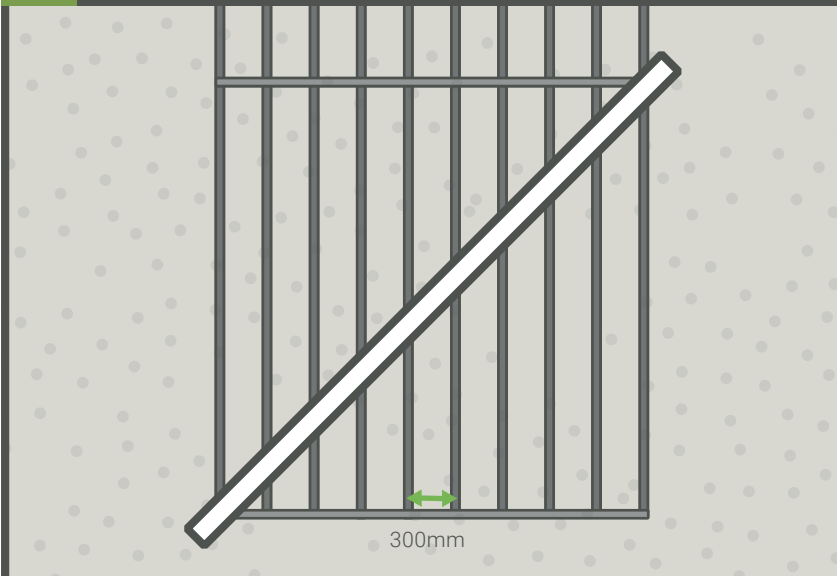

- i. Create your sub-frame as normal.
- ii. Place the central board first at a 45° angle.
- iii. Whenever the board crosses a joist, fix using a Quick clip.



We recommend ordering 15% more decking board material, as you will generate more scrap from cutting using this method.



If laying boards diagonally, joists must be placed no more than **250mm** apart. For commercial projects, this is **150mm**.

## ADVANCED TECHNIQUE DIAGONAL BOARDS

2



Place and fix remaining boards, lining up with the central board.

## ADVANCED TECHNIQUE DIAGONAL BOARDS

3

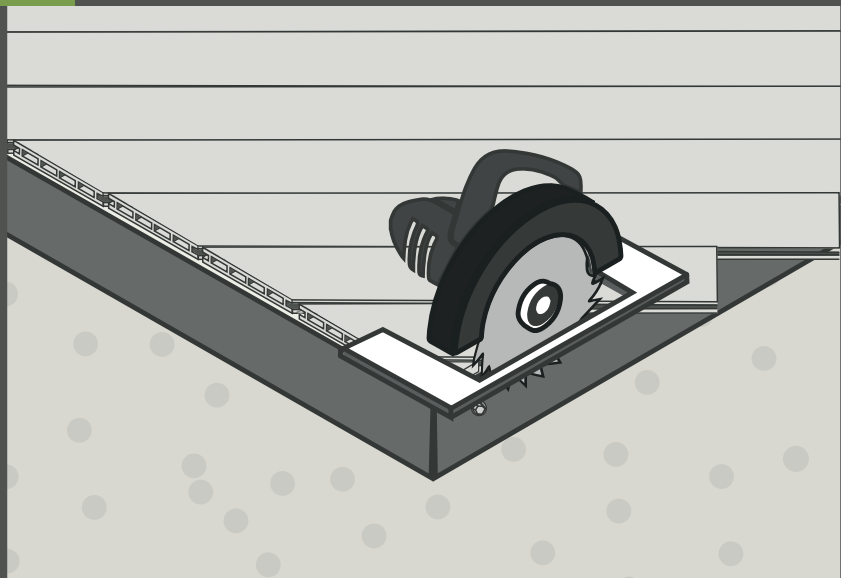

- i. Allow an overhang over the edge of the sub-frame.
- ii. Once all boards have been fitted, trim the overhang with a circular saw.



Take care not to scratch the boards.

## ADVANCED TECHNIQUE PICTURE FRAMING

Fit picture frame boards that run **PARALLEL** to the decking boards just like a normal end board, using method 2 (pg 42).

For picture frame boards that run **PERPENDICULAR** to the decking boards, follow these steps.

If you plan to border your decking with a picture frame, remember to include this in your initial measurements when calculating materials.

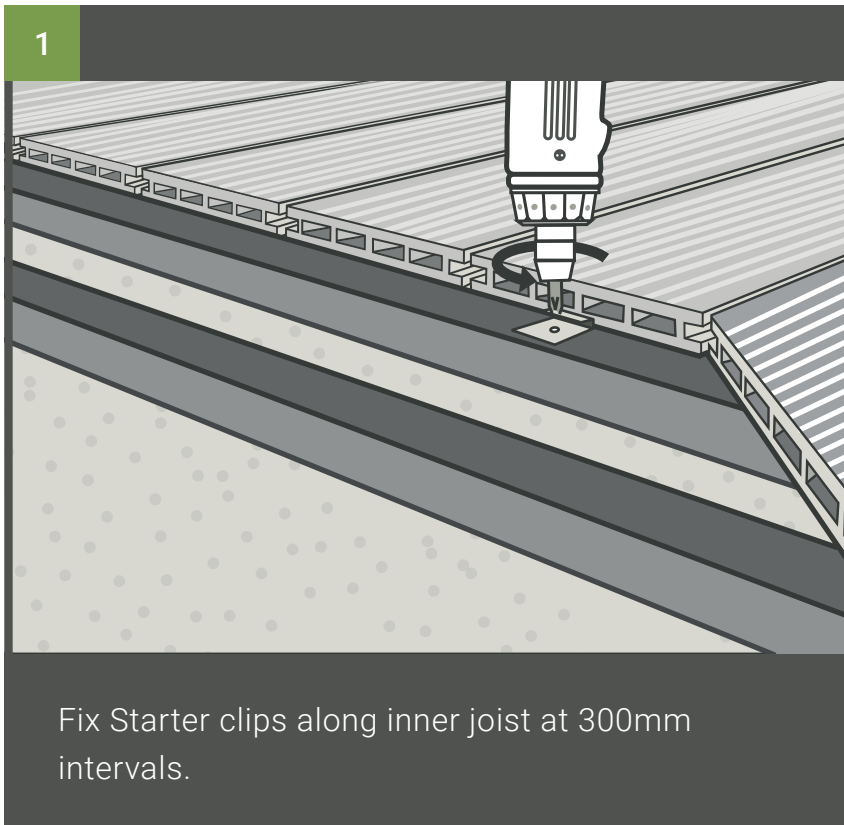

Fit the rest of your decking boards before beginning your picture frame.



Use a mitre square and circular saw to mitre the ends of each picture frame board.



You will need to lay extra joists around your sub-frame to support the picture frame.

## ADVANCED TECHNIQUE PICTURE FRAMING

For picture frame boards that  
run **PERPENDICULAR** to the  
decking boards (continued)

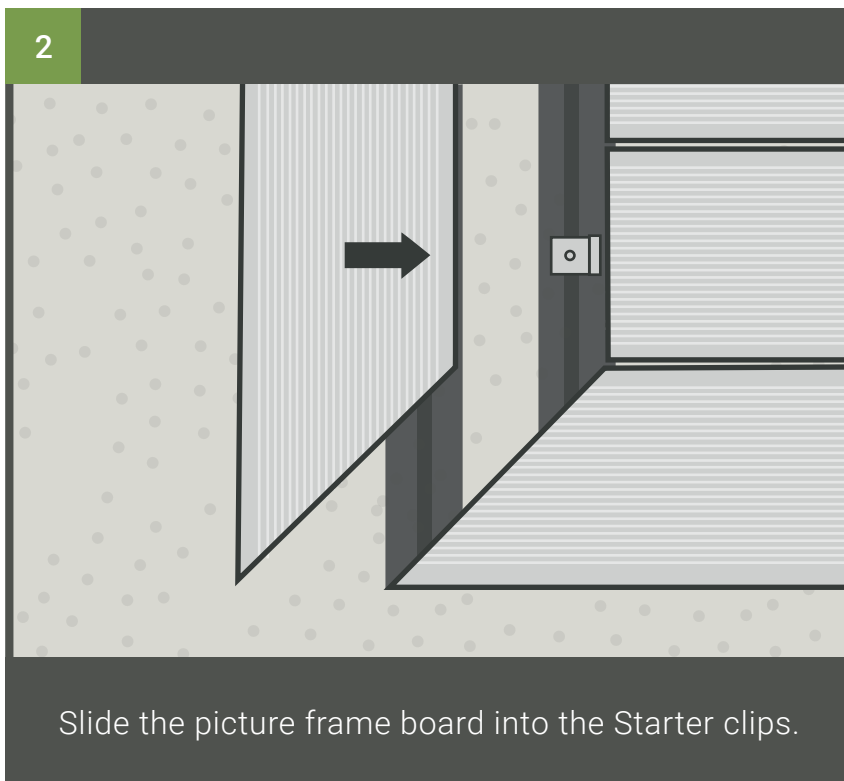

## ADVANCED TECHNIQUE PICTURE FRAMING

For picture frame boards that  
run **PERPENDICULAR** to the  
decking boards (continued)

3

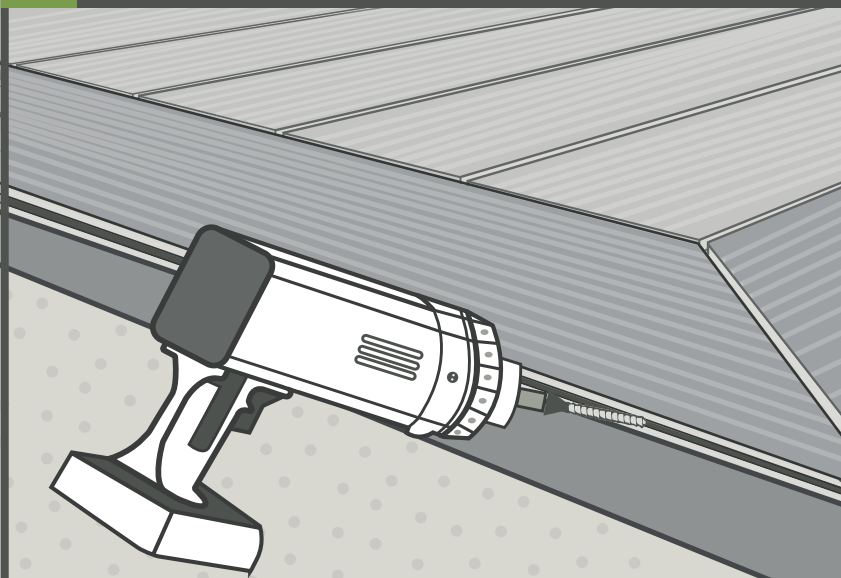

Screw through the groove in the board at a 45°  
angle, securing it to the perimeter joist.



Pre-drill pilot holes  
through the board  
to avoid splitting  
the material.



Do not overdrive  
the screws as this  
may cause the  
material to split.



Additional fittings  
may be required  
for this stage.

# 6. Finishing touches

## 6.1 About finishing boards

Finishing boards can be used to give your decking a finished look. There are three types of finishing board:

- Fascias
- Skirting
- Corner trim

Fascia boards and skirting boards are both fitted vertically to the edge of your decking

to create a finished look. The board you choose will depend on the range you are using and the finish you want.

Corner trim boards fit over the top corner of your decking to create a neat corner finish.

Install finishing boards after the rest of the decking boards have been installed.

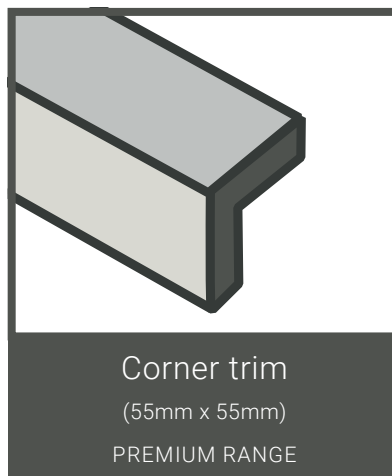
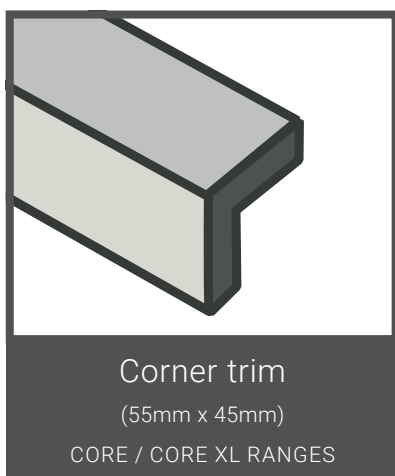
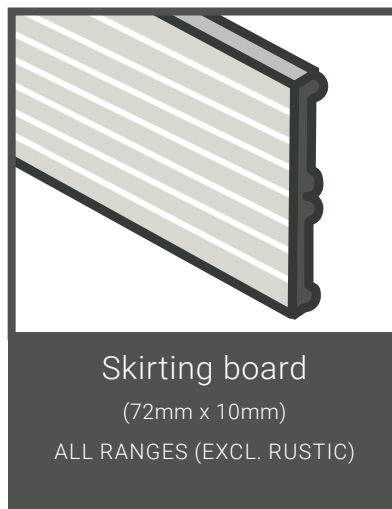
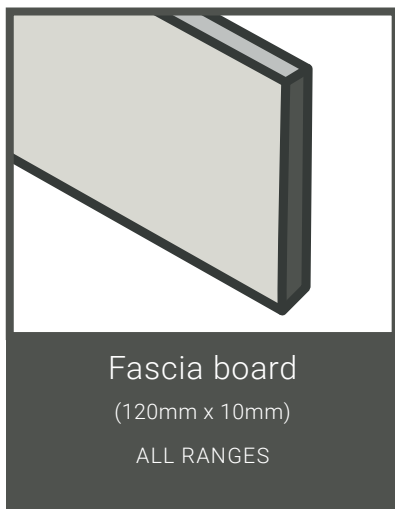

You **MUST** leave a ventilation gap beneath the finishing board to ensure adequate airflow beneath the deck:



Fix fascia and skirting boards at **600mm** intervals.  
Fix corner trim boards at **1000mm** intervals.

## 6.2 Installing fascia/skirting boards

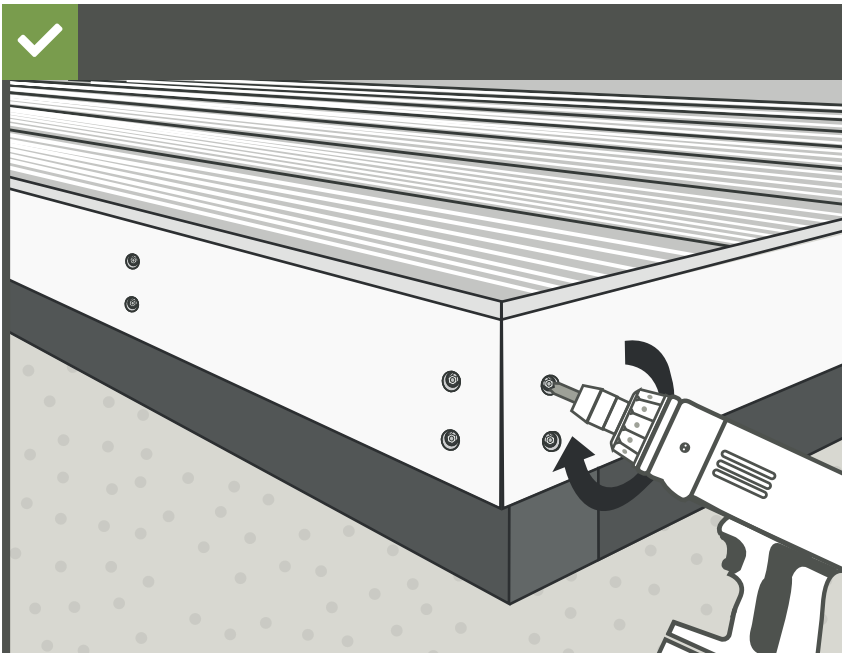

Line the top of the finishing board up with the top of your decking.

Fix the board in place with 40mm colour matched screws.

We do **NOT** recommend using adhesives to fix your finishing boards.



Note that installing fascias/skirting boards will result in visible screws in your deck finish.



Pre-drill countersunk pilot holes through the fascia board to avoid splitting the material.



Do not overdrive the screws as this may cause the material to split.



Additional fittings may be required for this stage.

### 6.3 Installing corner trim boards

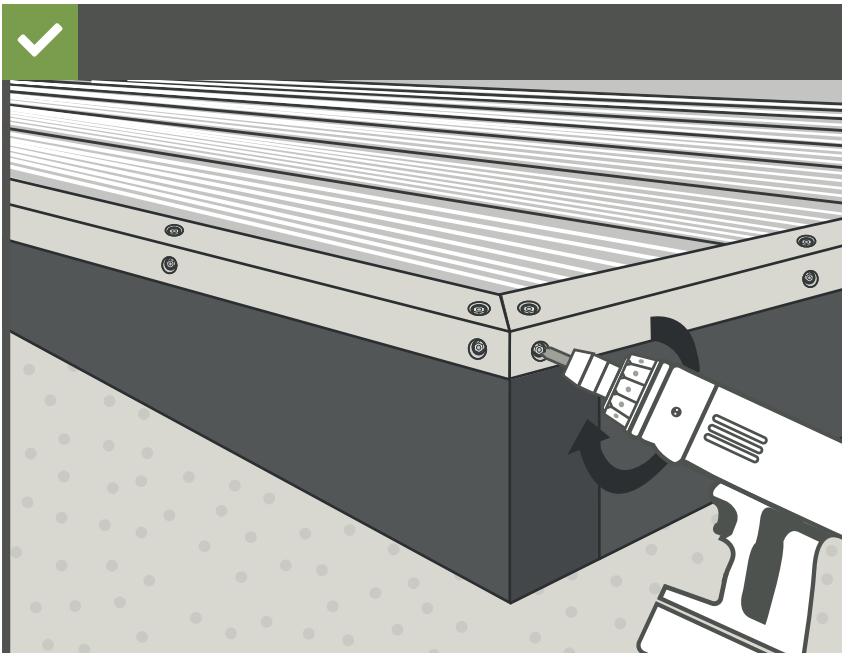

Fit the corner trim over the edge of your decking.

Fix the board in place with 40mm colour matched screws.

We do **NOT** recommend using adhesives to fix your finishing boards.



Measure the length of corner trim required and cut using a circular saw. Mitre the ends at 45° if installing at a corners.



Note that installing corner trim boards will result in visible screws in your deck finish.



Pre-drill countersunk pilot holes through the corner trim board to avoid splitting the material.



Do not overdrive the screws as this may cause the material to split.



Additional fittings may be required for this stage.

## ADVANCED TECHNIQUE STEPS

Composite decking boards can be used to create steps leading up to your deck.

First, you will need to build a box frame or step stringers to support the steps.

### Building the box frame

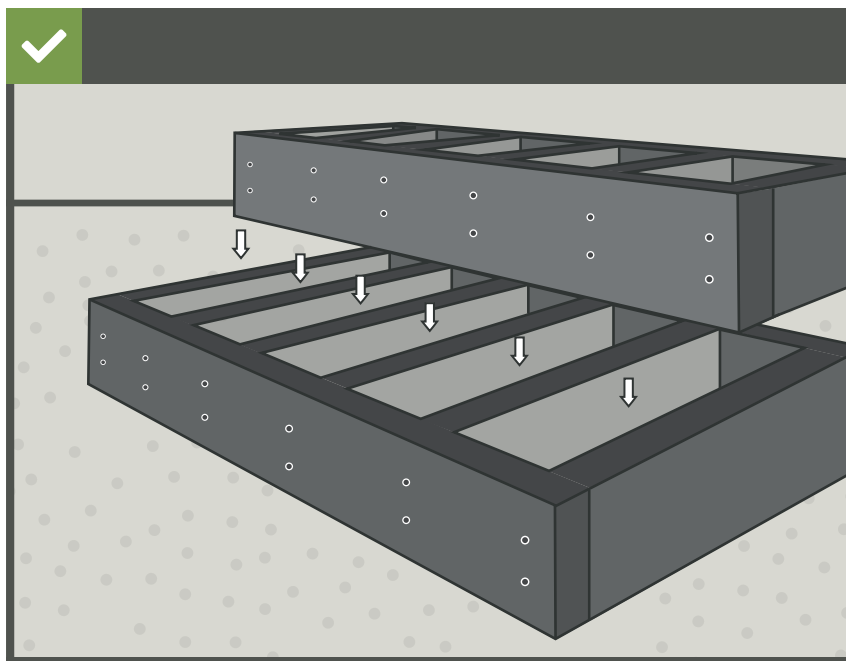

Use plastic wood joists (150mm x 50mm).

Ensure the lower box is large enough to support all the levels of steps.

Build an additional box frame for each level of steps, stacking them on top of the lower frame and securing in place.



You can use posts to secure the box frame into the ground if building on a soft uneven surface.



Each step can be no higher than **190mm** (commercial) or **220mm** (residential).

Please consult building regulations before starting.



Additional fittings may be required for this stage.

## ADVANCED TECHNIQUE STEPS

### Building the steps

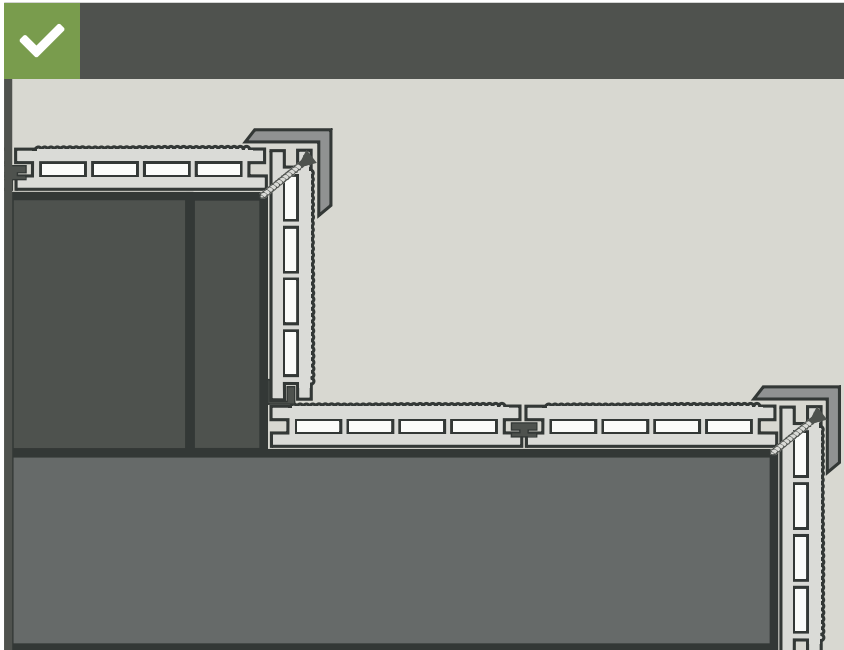

Use decking boards and fascia/skirting boards. Cut boards to size. Fix decking boards on horizontals using the normal clip method.

For the verticals, you can use either decking boards, fascias or skirting, depending on the range you have chosen and the finish you want.

Screw the vertical boards to the frame at a 45° angle.



You can use corner trim boards to reinforce your step edges.



**Premium / Supreme only**  
Bullnose boards can also be used to edge steps.



Pre-drill countersunk pilot holes through the boards to avoid splitting the material.



Do not overdrive the screws as this may cause the material to split.



Additional fittings may be required for this stage.

# CARE AND SUPPORT

# 8. Maintenance

## GENERAL CARE TIPS

Our products are designed to be low maintenance, but light cleaning and care can keep your decking looking brand new for longer.

Note that although our products are relatively colour stable, there may be some initial lightening as the product naturally weathers over the first 8-10 weeks.

Your decking can be washed with soapy water and a soft-bristled brush, or with a power washer. We recommend using no more than 1500psi pressure. Spray in the direction of the grain and use a fan tip nozzle.

## DIRT AND GRIME

Maintaining a clean, dry surface is the best method of combating dirt, grime and mildew build-up. Although our products are designed to inhibit mildew, stains can occur where moisture, pollen or dirt has built up.

## SPOT STAINS

Most stains can be removed using household cleaners. Soak the affected area as soon as possible, then scrub and rinse.

For more stubborn stains, we recommend using a composite-specific cleaner.

For very set stains, sand lightly with coarse sandpaper (60-60 grit), always in the direction of the grain. Be careful not to sand away the grain effect.

Cleaned or sanded areas may appear lighter. 8-10 weeks of sun exposure should correct this.

Like any wood-based product, composite products can sometimes experience a natural process known as extractive bleeding (also known as tea staining). This can cause temporary discolouration that will fade over time.

## SCRAPES AND SCRATCHES

Surface scratches and abrasions will fade with weathering. However, marks can be eliminated using a wire brush or coarse sandpaper (60-80 grit). Simply brush/sand in the direction of the grain until the mark has gone. The treated area will weather back in around 8-10 weeks.

## PAINTING AND STAINING

We do not recommend painting or staining your decking.

However, it is possible for our products to be painted or stained.

Wait until the product has been weathered for 8-10 weeks to ensure you are working with the final colour.

Clean and dry the surface before applying any product.

Always follow manufacturer's instructions when applying paint or stain.

## 9. FAQs

### Q. WHERE CAN I USE COMPOSITE DECKING?

A. Our decking ranges can be used in a variety of locations, both residential and commercial. Most common are external communal areas, balconies, pool sides, as well as many more practical uses.

### Q. WHAT COLOURS ARE AVAILABLE?

A. Our composite decking comes in a variety of colours. Visit our website or showroom to view the full range.

### Q. WILL THE COLOUR FADE OVER TIME?

A. Our decking products will naturally lighten over the first 8-12 weeks and then will stabilize after this period.

### Q. HOW SLIPPERY DOES THE DECKING BECOME WHEN WET?

A. Our decking is designed with micro-grooves that aid in slip-resistance. Regardless of conditions, our ranges can outperform timber. However, we recommend taking extra caution if the decking becomes wet.

### Q. HOW DO YOUR PRODUCTS REACT WHEN EXPOSED TO WATER?

A. Our products are designed to take on very little water (c.1%). Our ranges have a much lower absorption rate than timber, which greatly reduces the likelihood of wet rot developing.

### Q. DO YOU HAVE RECOMMENDED INSTALLERS I CAN USE?

A. We have an extensive network of recommended installers who we trust to bring your plans to reality.

We have chosen these installers for their high quality of work and professionalism, but as with any third party, we recommend that you follow your own precautions before entering into a contract with them.

### Q. DOES THE DECKING REQUIRE TREATING?

A. Our products are already coloured so do not require painting or treatment at all.

### Q. ANYTHING ELSE?

A. For any other technical, installation or care questions:

Call our technical team on **0115 684 8754**

Or email us at **info@selectlivinggroup.co.uk**

### Q. CAN I SEE SOME SAMPLES?

A. Simply go to our website to order your samples.